

# Biophysics I

## 1. Introduction, Radiations

Károly Liliom

12. 09. 2025.

[karoly.liliom.mta@gmail.com](mailto:karoly.liliom.mta@gmail.com)

# What is the subject of biophysics?

## Physical backgrounds of biological processes

E.g.: electrophysiology of heart, structure and function of membranes, sensory functions,...

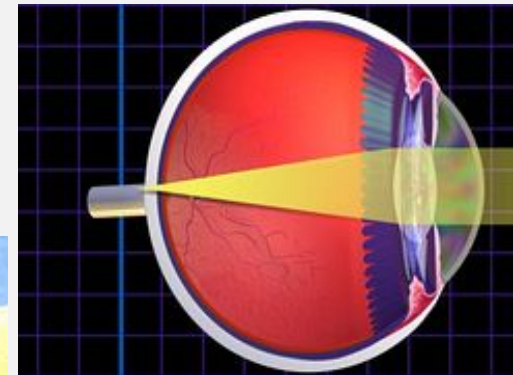
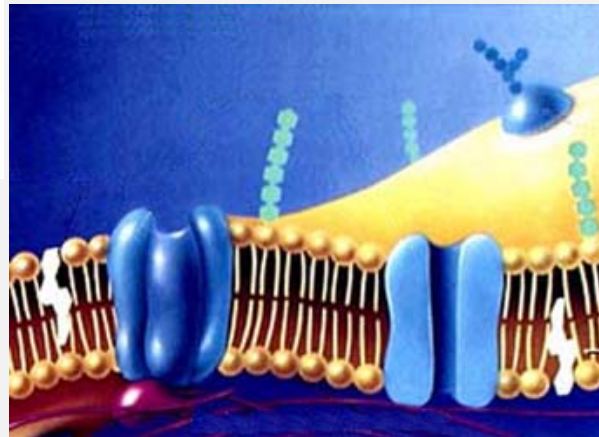
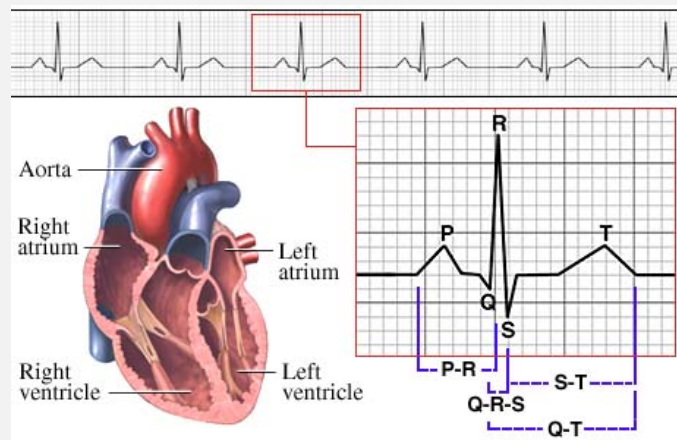

# What is the subject of biophysics?

Physical methods in biology and medicine

E.g., ECG, X-ray diagnostics, microscopy....

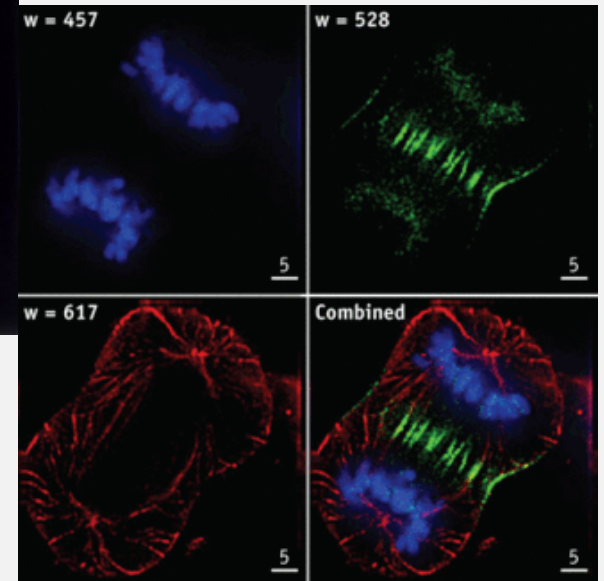

# Scientific method

Observations, experiments = data collection

Data analysis = finding causative relations among data

Relations = mathematical models describing the dependence of observations on independent variables (parameters)

Model building is always simplification. Based on a model, we make assumptions out of the known observation to validate them experimentally. If the new results agree with the model prediction than we keep the model, if not than we must modify the model = scientific models are **falsifiable!** = experimental results support or disprove a model. Occam's razor = from alternative explanations (models) of a phenomenon, we should select the one posits the fewest assumptions.

Medical sciences, dentistry (!)

# Math and physics we need for biophysics

*(formula collection)*

quantitative models = mathematical functions

an example – how the index of refraction changes as a function of the concentration of soluts in diluted solutions?  $n = n_0 + k \cdot c$

*what we need:*

- *linear function*
- *power function*
- *exponential and logarithmic function*
- *harmonic function*

*good to know:*

- *transformations of formulas*
- *vectors*
- *units*

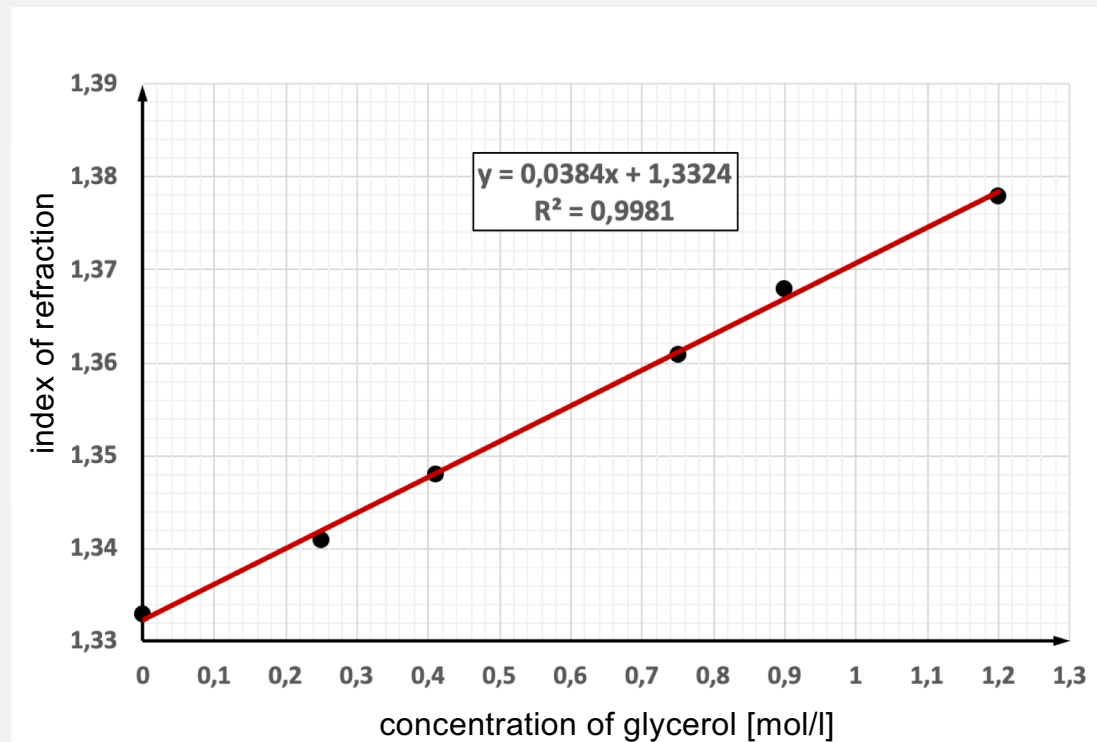

# Physical bases of biophysics



Department of Biophysics and  
Radiation Biology  
Semmelweis University - Faculty of Medicine

Home **Education** Research Services Staff Contact

**Faculty of Medicine**  
Biophysics Labs  
Mathematical and Physical Basis of  
Medical Biophysics  
Medical biophysics 1.  
Medical biophysics 2.  
Medical statistics, informatics and  
telemedicine  
Teaching assistant work

**Faculty of Dentistry**  
Biophysics 1. Dentistry  
Biophysics 2. (Dentistry)  
Biophysics Labs  
Physical bases of biophysics  
Physical Foundations of Dental  
Materials Science  
Teaching assistant work

**Faculty of Pharmacy**  
Biophysics 1.  
Biophysics 2.  
Biophysics Labs  
Physical bases of biophysics  
Teaching assistant work

**Other undergraduate education**

## Physical bases of biophysics 2021-2022

Information **Lectures** Exam

### General information

Elective course (lectures only)  
1 credit

The course will be held in Hári lecture hall during the first four Tuesdays (19:10 - 20:40) and Fridays (16:50 - 18:20) of the semester.

**Important:** passing the closing test from the course material is mandatory for all medical students. Passing the test is a requirement for obtaining a signature in Biophysics I.

Therefore, we recommend it to every student to attend this course, as it will help in preparing for the mandatory test and for studies in Biophysics.

**Closing test of the course:** the date will be announced later

### Aims of the subject within the medical studies

The aim of the subject is to remedy the deficiencies in the education of mathematics and physics in secondary schools, and to provide the background knowledge necessary for the Biophysics subject.

### Supporting educational material (textbooks, notes etc.)

- Physical Bases of Biophysics (manual)
- Unit conversion
- Transposition of formulae

## Mathematical and Physical Basis of Medical Biophysics

Supplementary material for the  
„Medical Biophysics” and „Biophysics” courses

Edited by: Dr. Ferenc Tölgyesi, associate professor

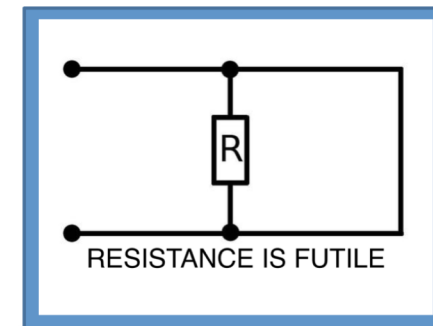

Semmelweis University  
Department of Biophysics and Radiation Biology  
2016

Important concepts: energy (work, power), momentum, force (fields), kinematics (velocity, acceleration)...

# Topic list of the first semester

- 1 Introduction to biophysics, radiations, elektromagnetic spectrum
- 2 Ray optics: Fermat's principle, refraction, lenses, microscope
- 3 Wave optics: Huygens's principle, diffraction, interference, resolution
- 4 Light interacting with matter: scattering, absorption, reflection, color vision
- 5 Atoms, molecules, structure of matter
- 6 Thermal emission; emission of human body, infradiagnostics
- 7 Luminescence, applications in medicine
- 8 Lasers, applications in medicine
- 9 Photobiology, applications in medicine
- 10 Modern microscopy techniques
- 11 X-ray: production, characteristics, and applications
- 12 Bases of X-ray diagnostics
- 13 Nuclear radiations, bases of isotope diagnostics
- 14 Clinical applications of nuclear radiations

# Radiations

radiation = release (emission) and transfer (propagation) of energy (in the form of waves or particles)

Examples:

sound, light

radiowaves, X-ray

nuclear radiations

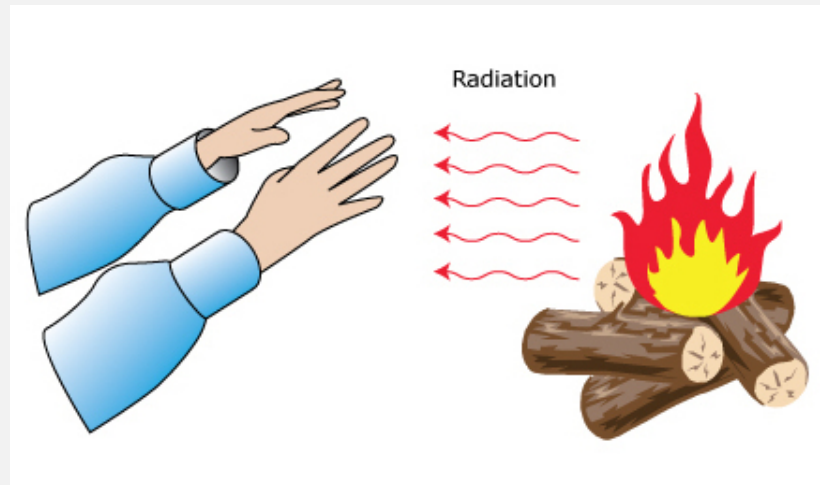

# Classification of radiations

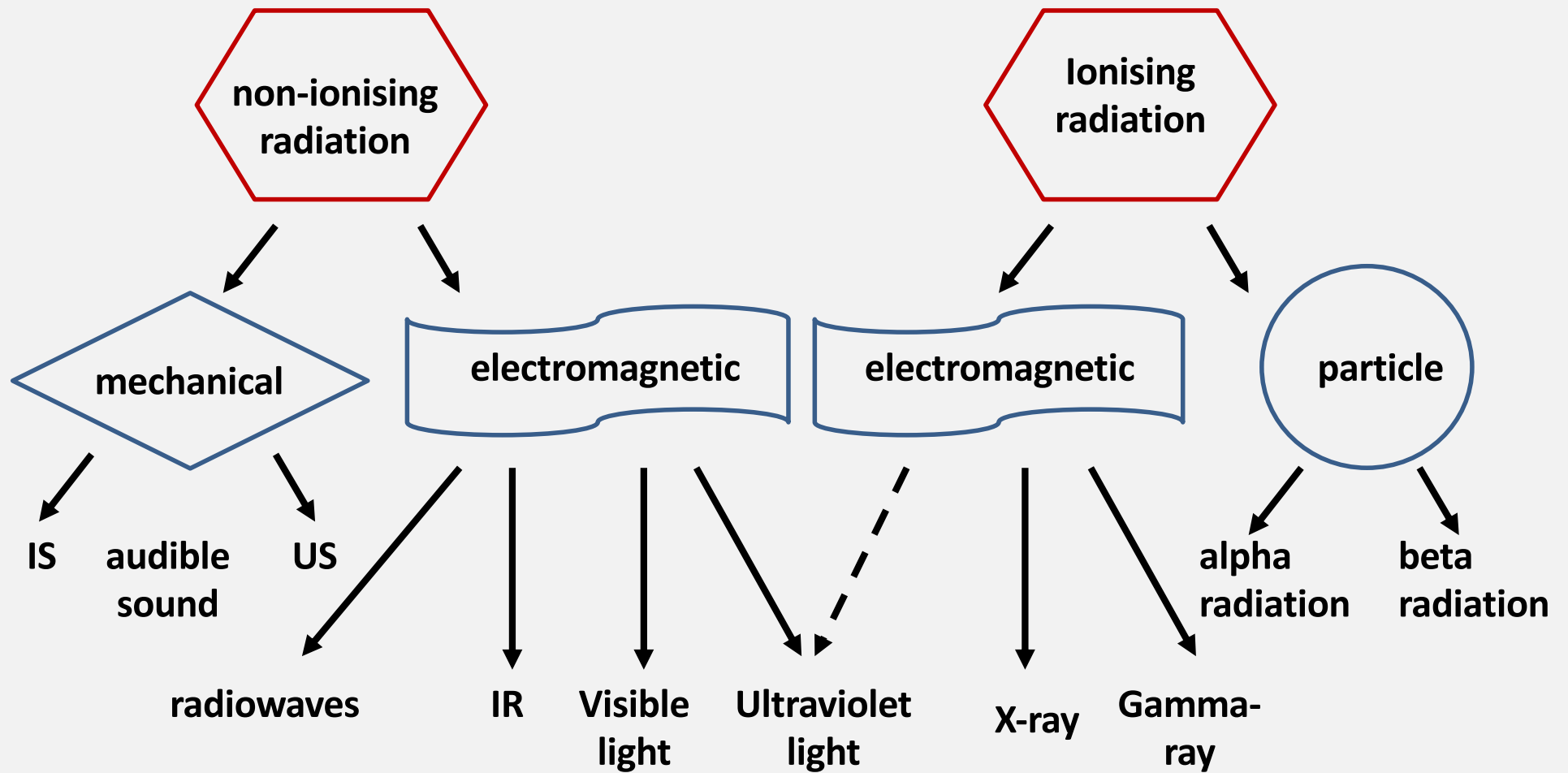

# Classification of radiations

non-ionising  
radiation

Ionising  
radiation

What is the basis of classifications?

IONISATION

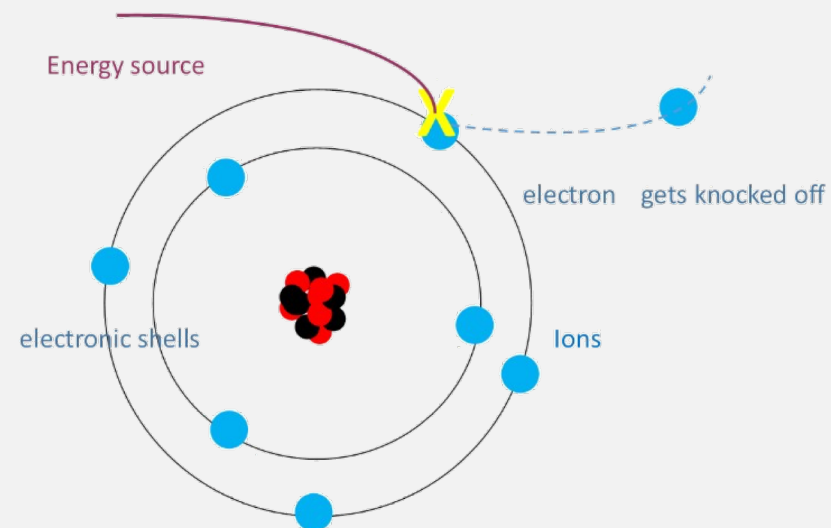

# How to characterize the energy in the radiation

radiant emittance:

$$M = \Delta P / \Delta A = \Delta E / \Delta t \Delta A$$

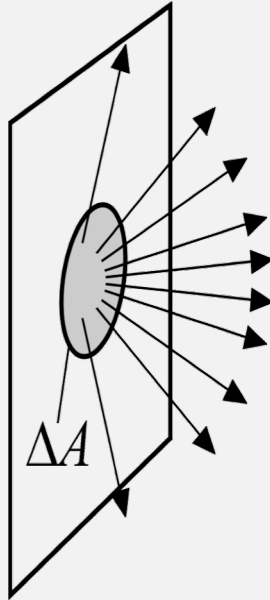

irradiance:

$$E_{in} = \Delta P / \Delta A \text{ (W/m}^2\text{)}$$

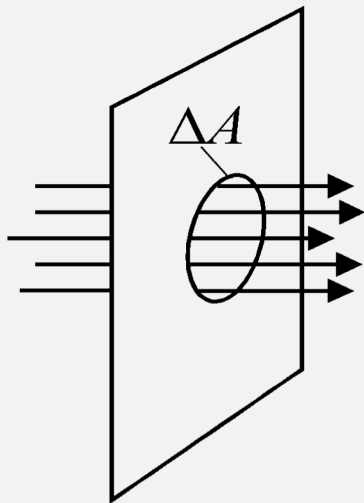
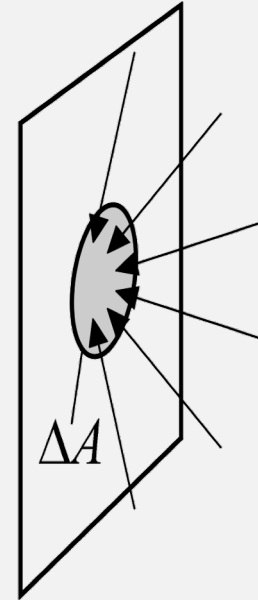

intensity of a radiation = the energy flowing across a unit area perpendicular to the direction of radiation, per unit time

$$J_E = \Delta E / \Delta t \Delta A$$

# General description of waves

periodic disturbances in space and time, transferring energy



Waves differ in  
type of energy  
intensity  
mechanism of propagation

# Characteristic values

Period in space – *wavelength*

$$\lambda \text{ [m] or [nm]}$$

displacement – *amplitude*

$$E \sim A^2$$

Period in time – *period, T*

– *frequency, f*

$$f = \frac{1}{T} \left[ \frac{1}{s} \right]$$

velocity of waves:  $c = \lambda/T = \lambda f$

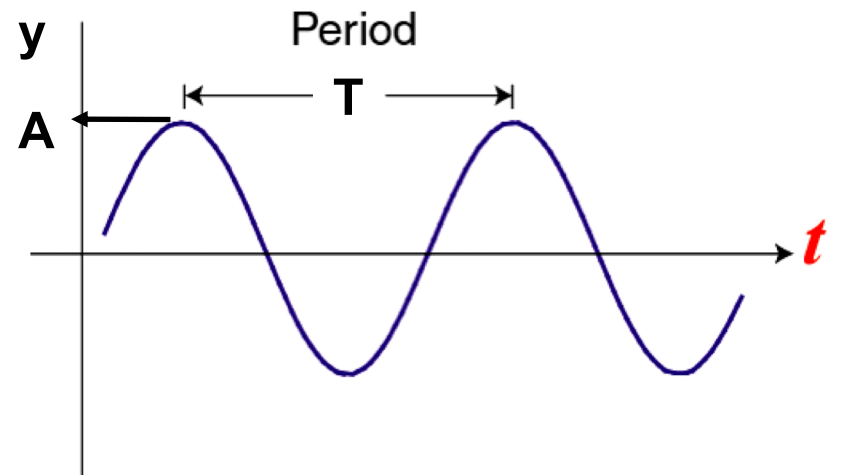
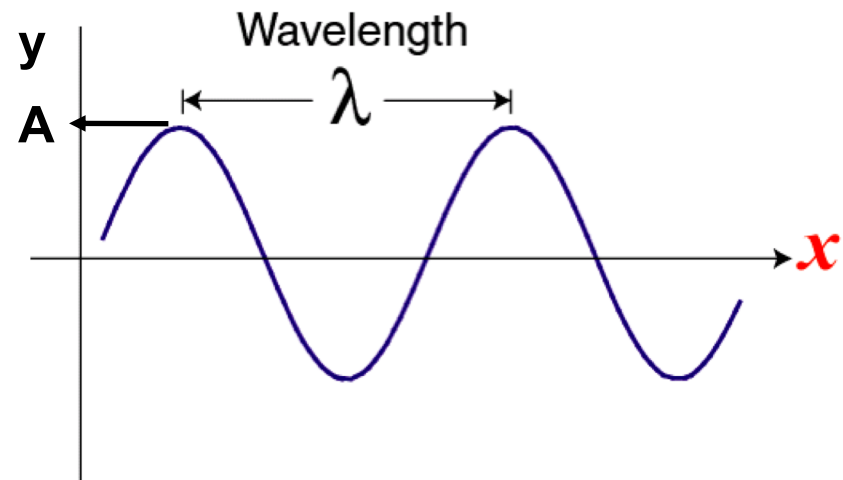

*Phase*: the location or timing of a point within a period

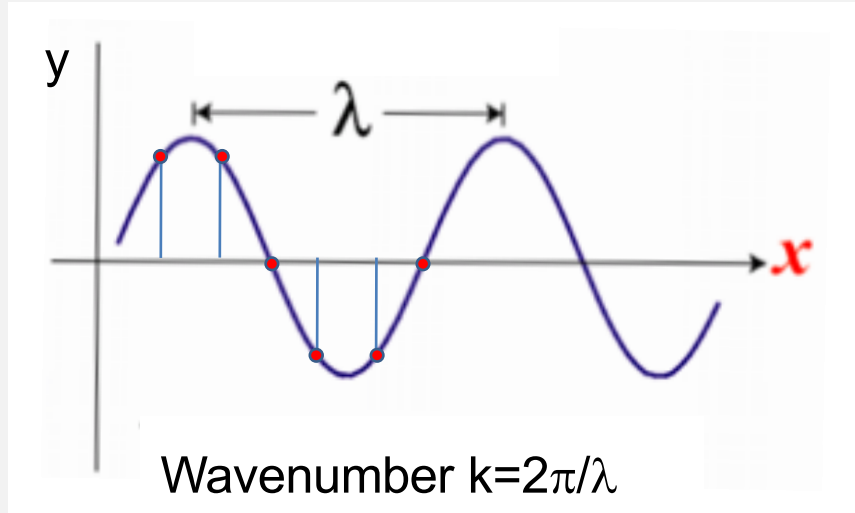

$$\phi(x) = kx + \phi_0$$

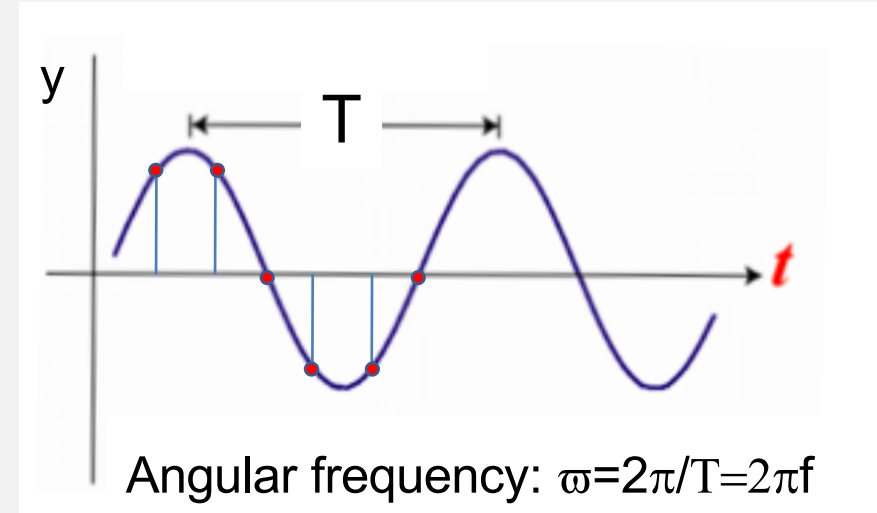

$$\phi(t) = \omega t + \phi_0$$

$$\phi = \omega t + kx + \phi_0$$

Phase: fraction of the wave cycle that has elapsed relative to the origin

## Features shown by waves:

- diffraction
- superposition / interference
- polarization

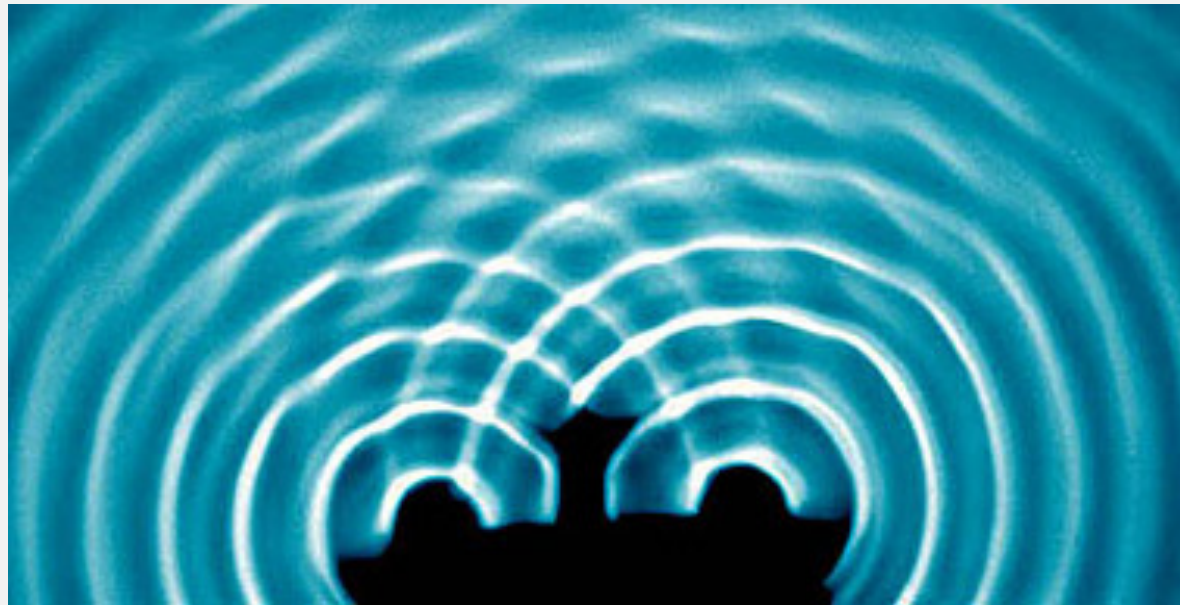

# *Diffraction*

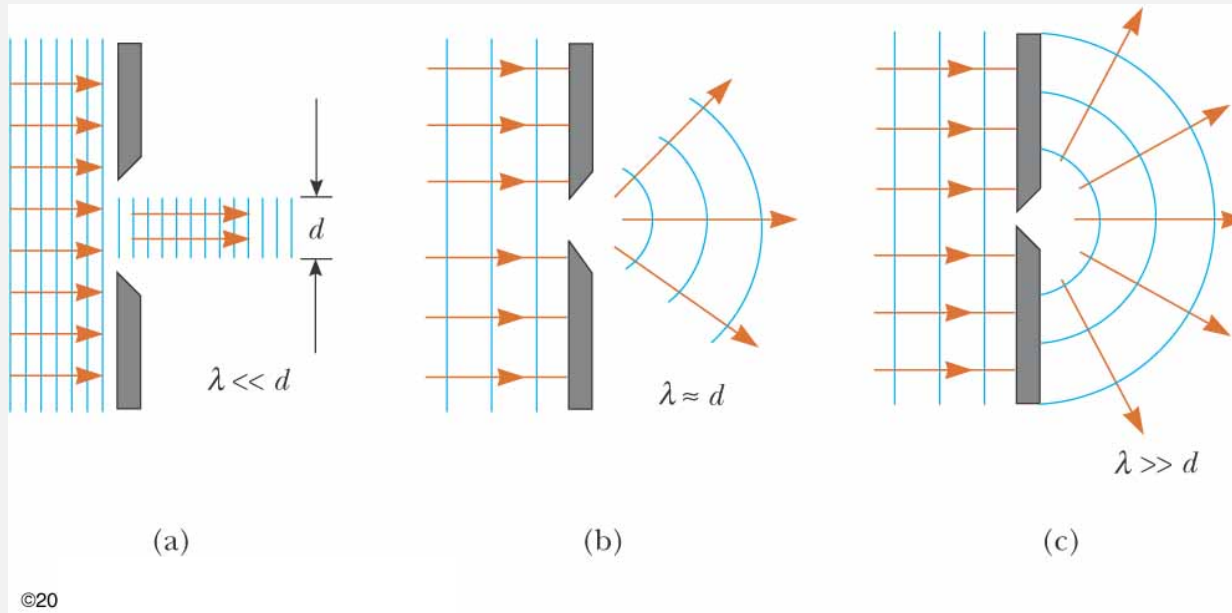

Huygens' principle: every point in a propagating wavefront serves as the source of spherical secondary wavelets, such that the wavefront at some later time is the envelope of these wavelets.

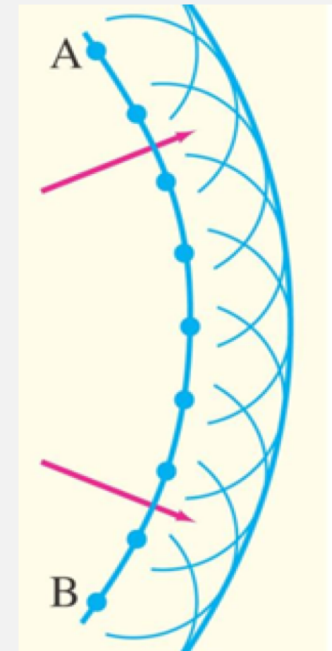

*Superposition:* The principle of superposition applies to waves whenever two (or more) waves traveling through the same medium at the same time. The net amplitude of the waves at any point in space or time, is simply the sum of the individual wave amplitudes.

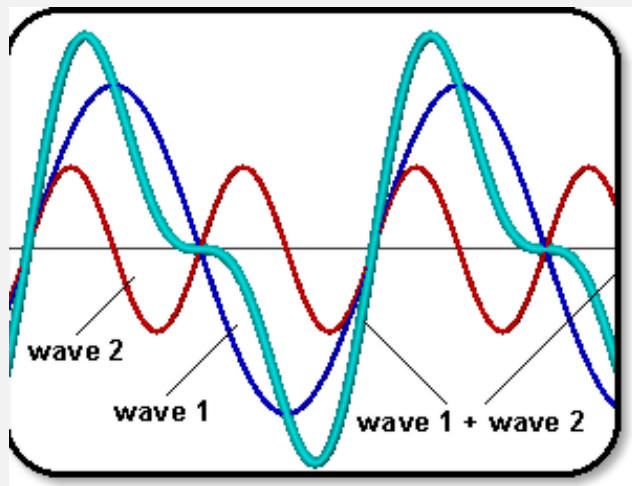

Un-equal frequencies

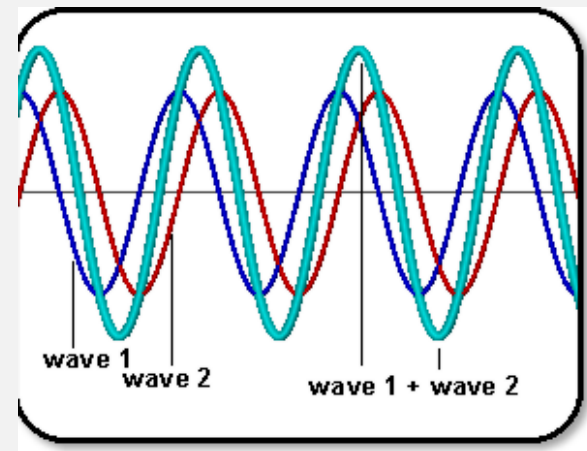

Equal frequencies

*Interference*: superposition of coherent waves

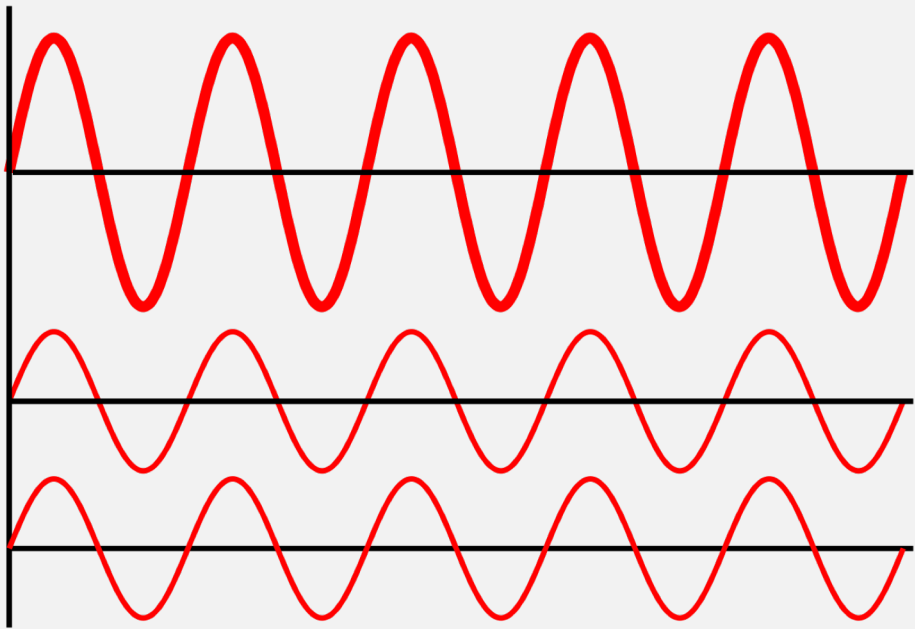

Similar phases

Constructive interference

$$\Delta\Phi = 0^\circ$$

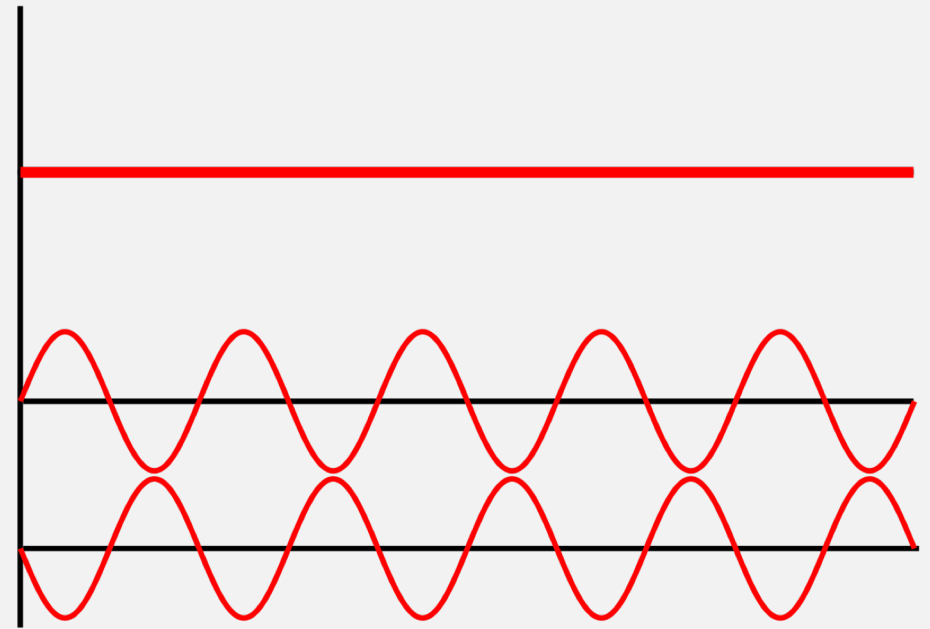

Opposite phases

Destructive interference

$$\Delta\Phi = 180^\circ$$

# The nature of light is...

wave?

or

particle?



**Christiaan Huygens**

(1629 - 1695)

*Traité de la lumière*

1690

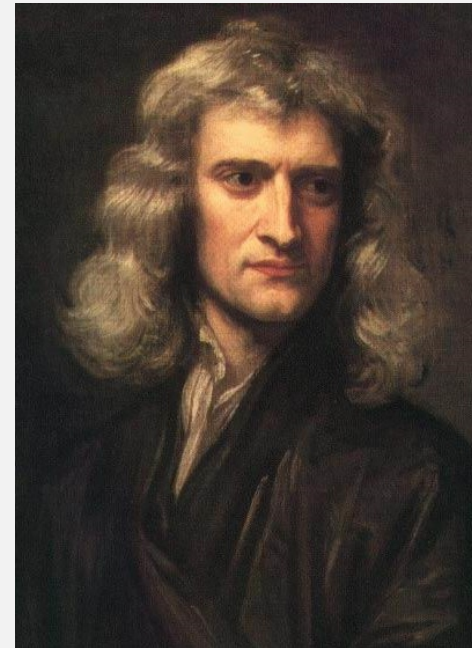

**Isaac Newton**

(1642 - 1727)

*Opticks*

1704

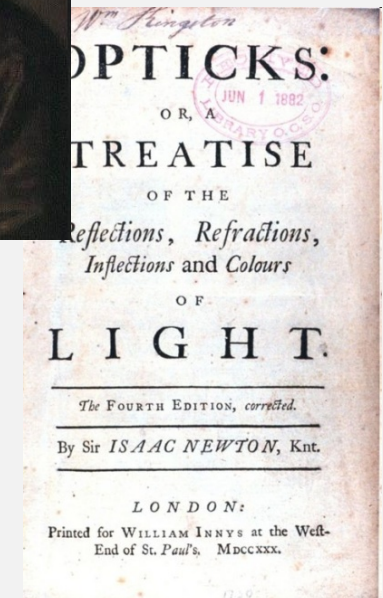

# Wave or particle?



**Thomas Young**  
(1773-1829)

## 1. Thomas Young's double-slit experiment

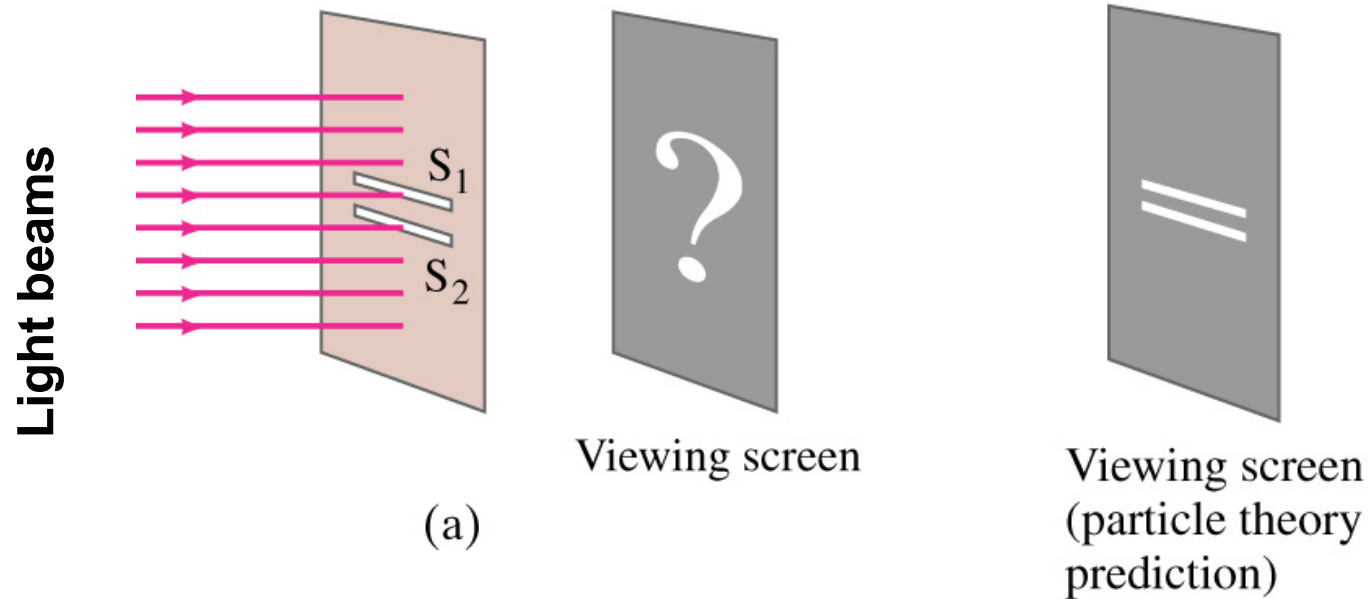

# Wave or particle?



**Thomas Young**  
(1773-1829)

## 1. Thomas Young's double-slit experiment

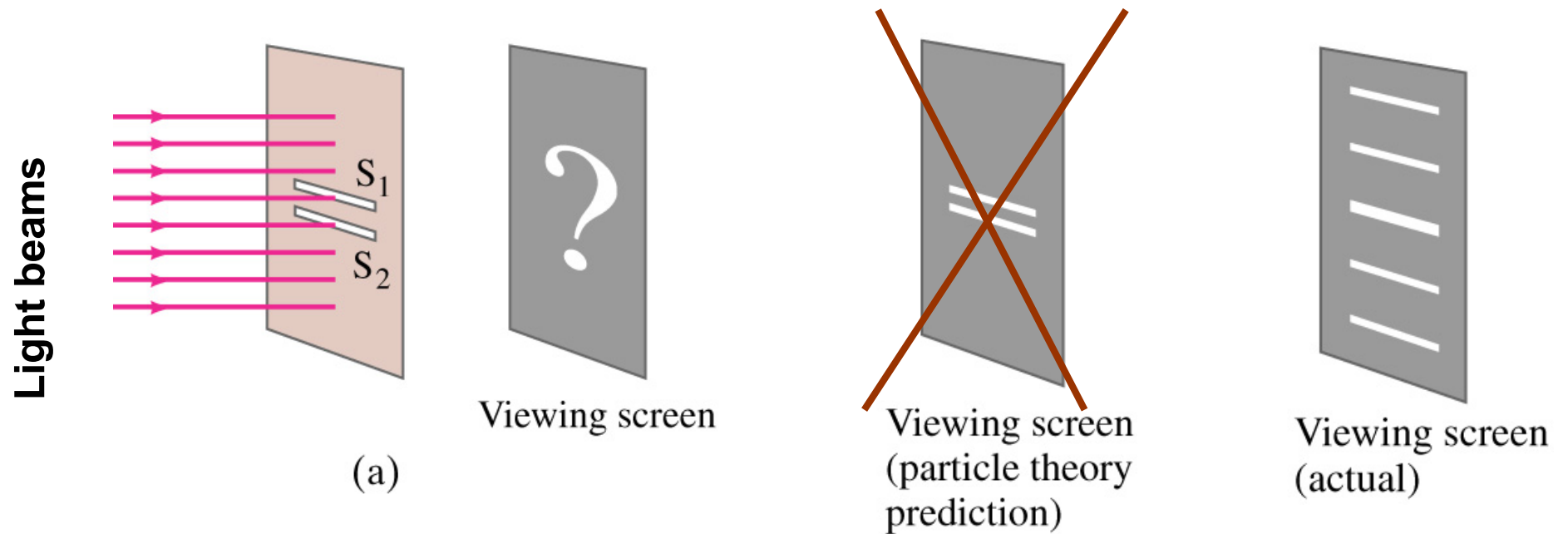

## *Interpretation of Thomas Young's double-slit experiment*

$S_1$  and  $S_2$  slits are sources of waves

Two waves from  $S_1$  and  $S_2$  originates from the same wavefront, that is they are in the same phase.



**interference**

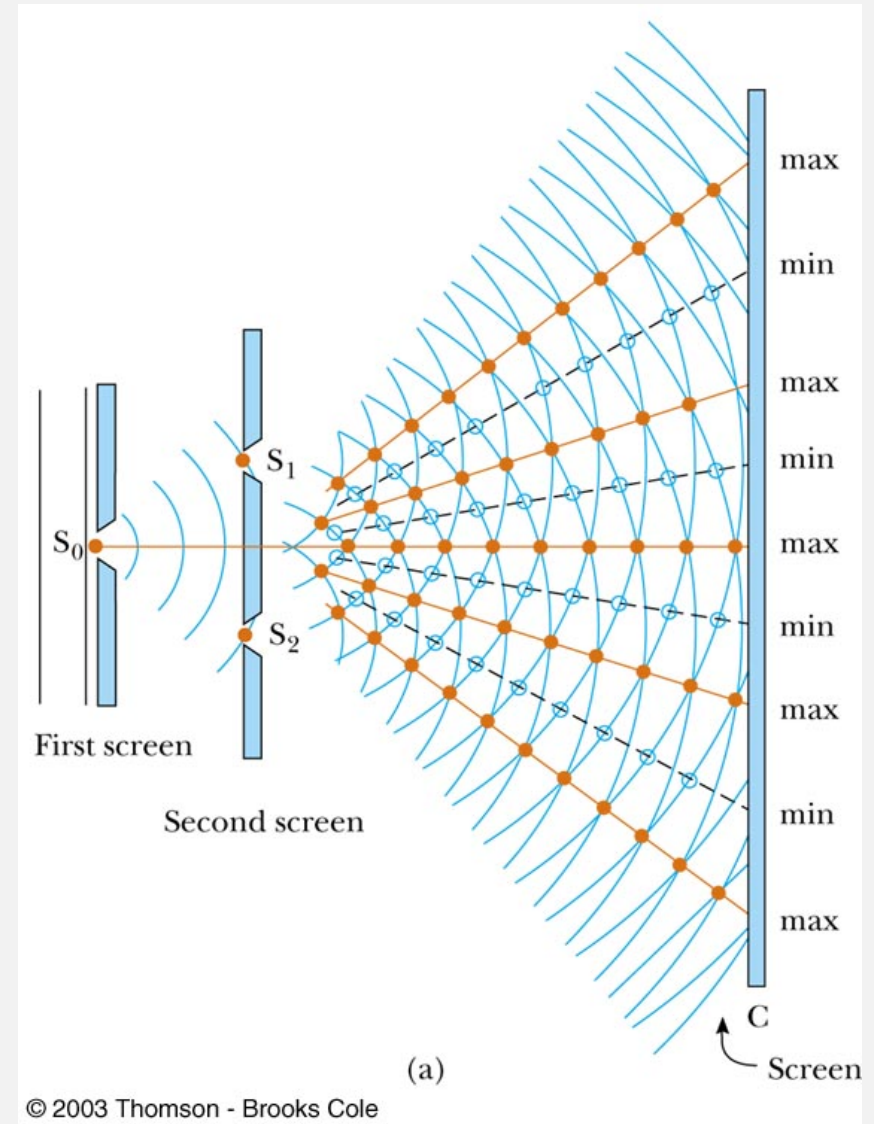

Interference fringes on a screen

# *Dispersion of light by a diffraction grating*

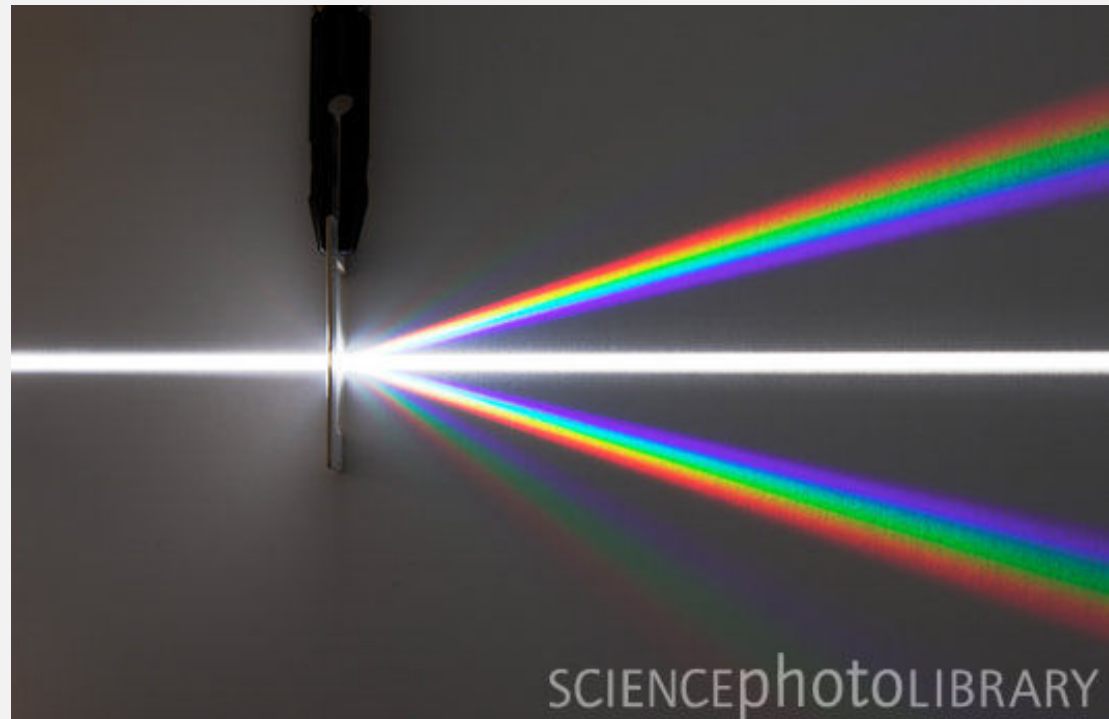
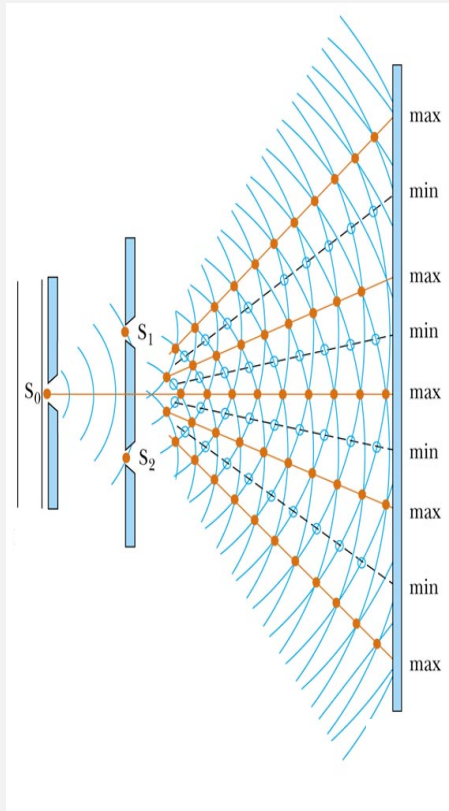

# Wave or particle?

## 2. Hertz's experiment



**Heinrich Hertz**  
**1887**

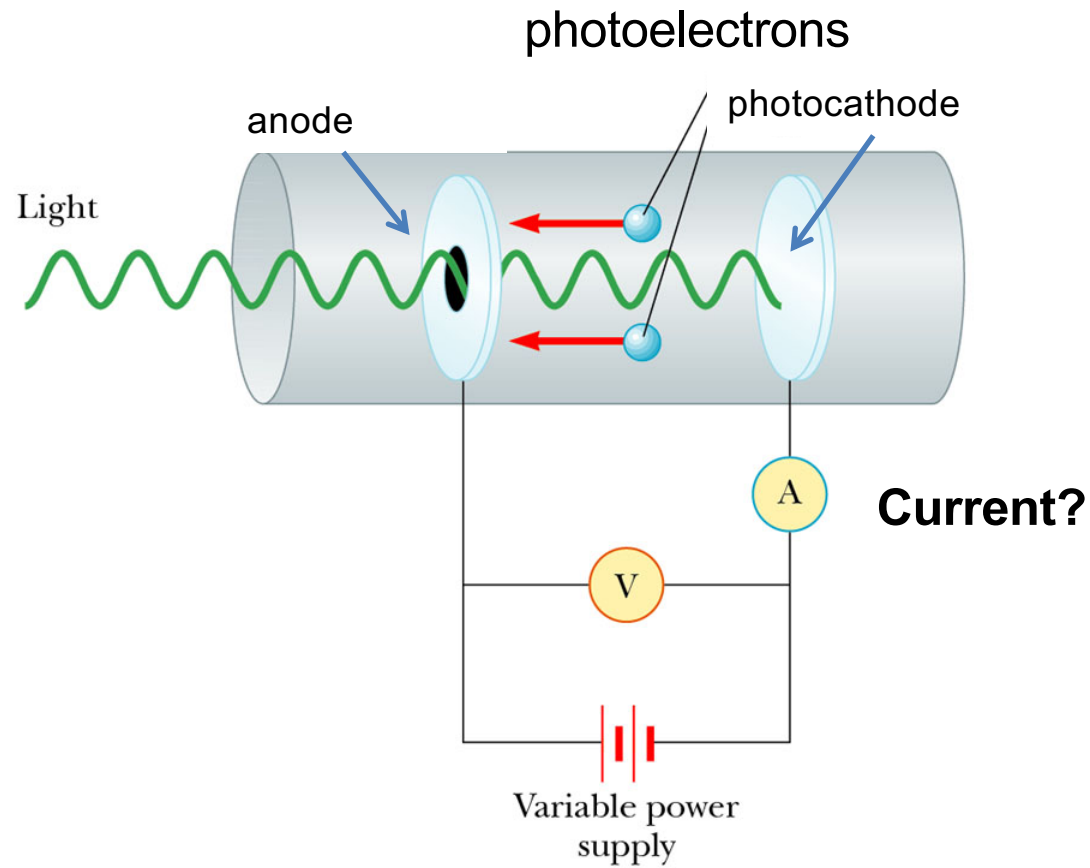

**Photoelectric effect**

# Light irradiation with

Similar color / wavelength

Similar amplitude

increasing  
amplitude / intensity

variation in color / wavelength

Current?

Current?

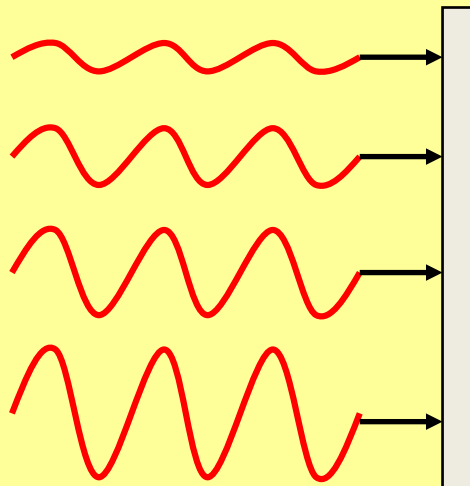

no

no

no

no

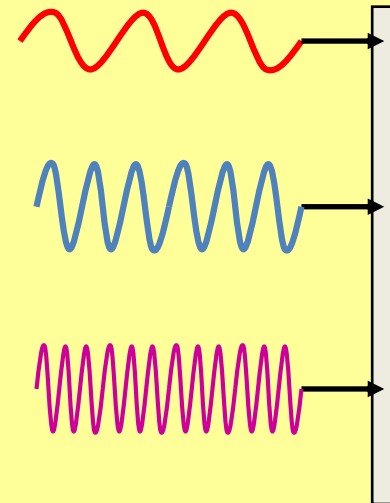

no

yes

yes

No current below a critical frequency!

# Interpretation of photoelectric effect by Einstein

- Based on the wave character it is not possible!
- Planck - foundation of quantum physics (1900):  $E=hf$
- Einstein's concept is based on quantum theory (1905)

**Max Planck**

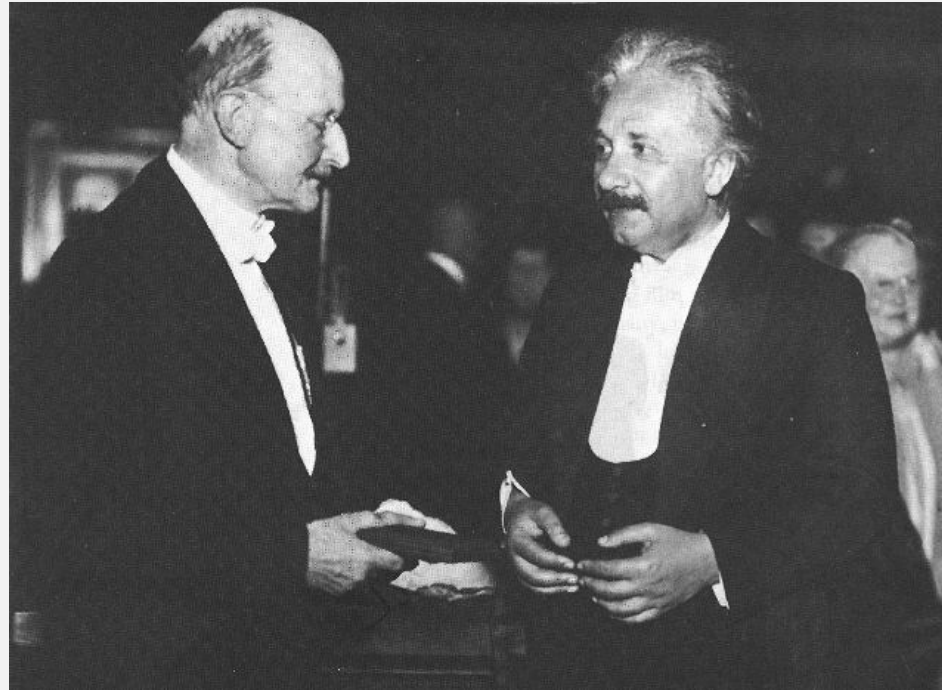

**Albert Einstein**

Nobel Prize in physics 1918

*"in recognition of the services he rendered to the advancement of Physics by his discovery of energy quanta".*

Nobel Prize in physics 1921

*for his services to Theoretical Physics, and especially for his discovery of the law of the photoelectric effect".*

## *Einstein's interpretation*

- Light consists of a finite number of energy quanta - photons
- The energy of a photon:  $E = hf$
- Photon can be absorbed or generated only as complete units
- A photon transfers its energy to one electron if the photon energy is equal or higher than the work function (= A)
- No interaction, if the photon energy is below the work function
- 1 photon – 1 electron interaction
- Kinetic energy of the released electron:  $E_{kin} = hf - A$

## *Einstein's interpretation and the frequency limit*

Kinetic energy of the emitted electron is proportional to the frequency.

Intercept with the  $x$  axis is the smallest frequency inducing photoelectric effect

$f_{\min}$  depends on the cathode material:

$$A = hf_{\min}$$

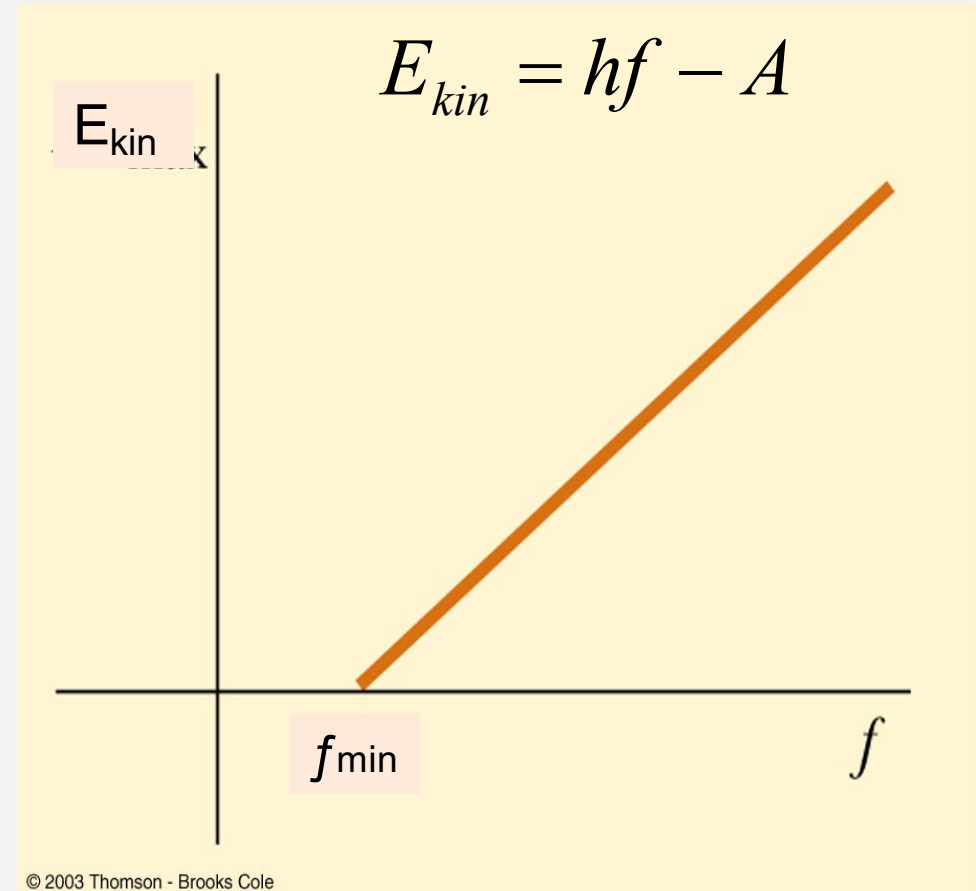

# Dual nature of light

Particle – its energy is quantized, a photon is an elementary particle, the quantum of the electromagnetic interaction

Energy of photon:  $E = hf = h \frac{c}{\lambda}$

Planck constant:  $h = 6.62 \cdot 10^{-34} \text{ Joule} \cdot \text{s}$

Photons have no resting mass and propagate in vacuum

# Dual nature of light

Wave – electric and magnetic fields vary sinusoidally

## Electromagnetic radiation

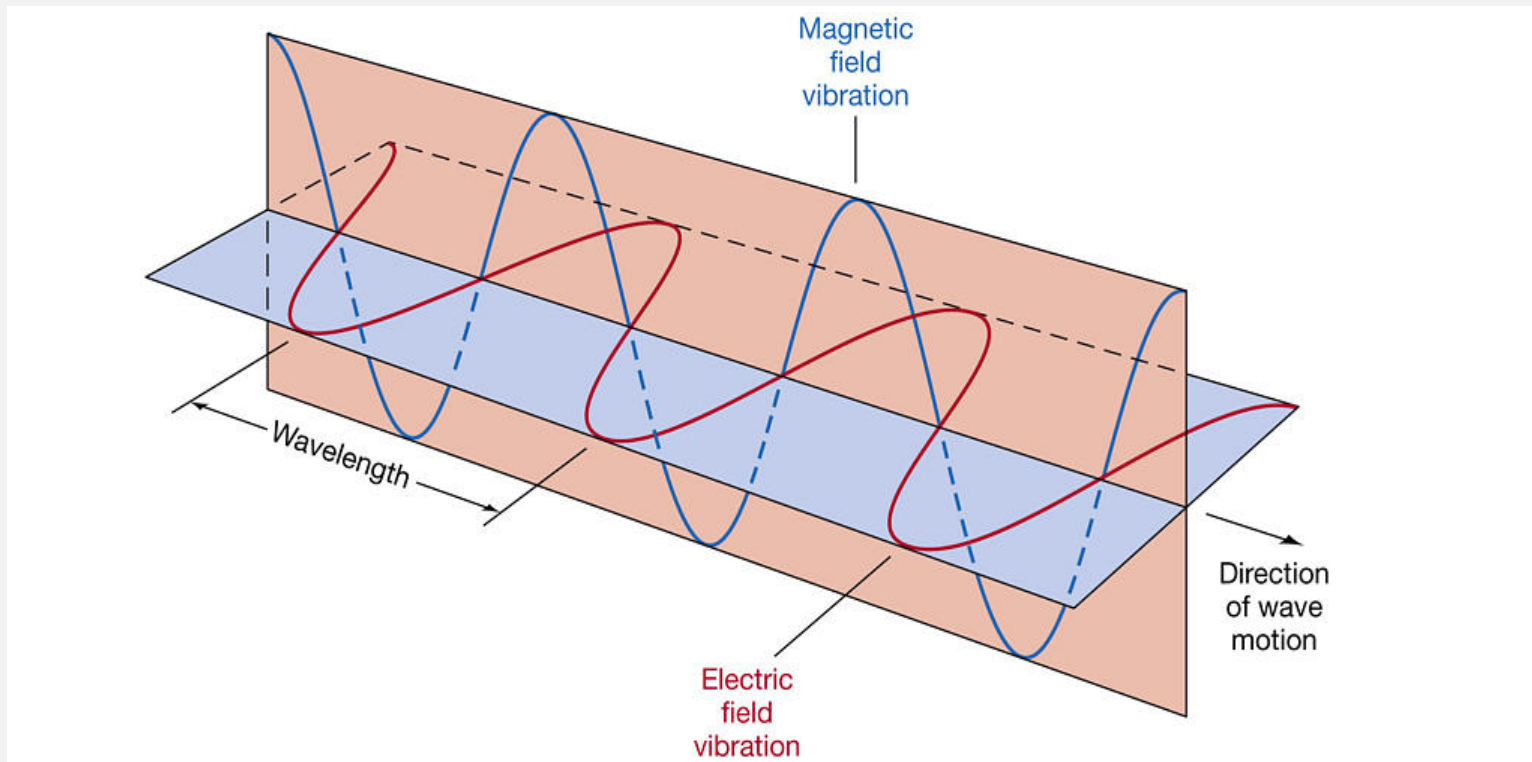

# Classification of electromagnetic radiation

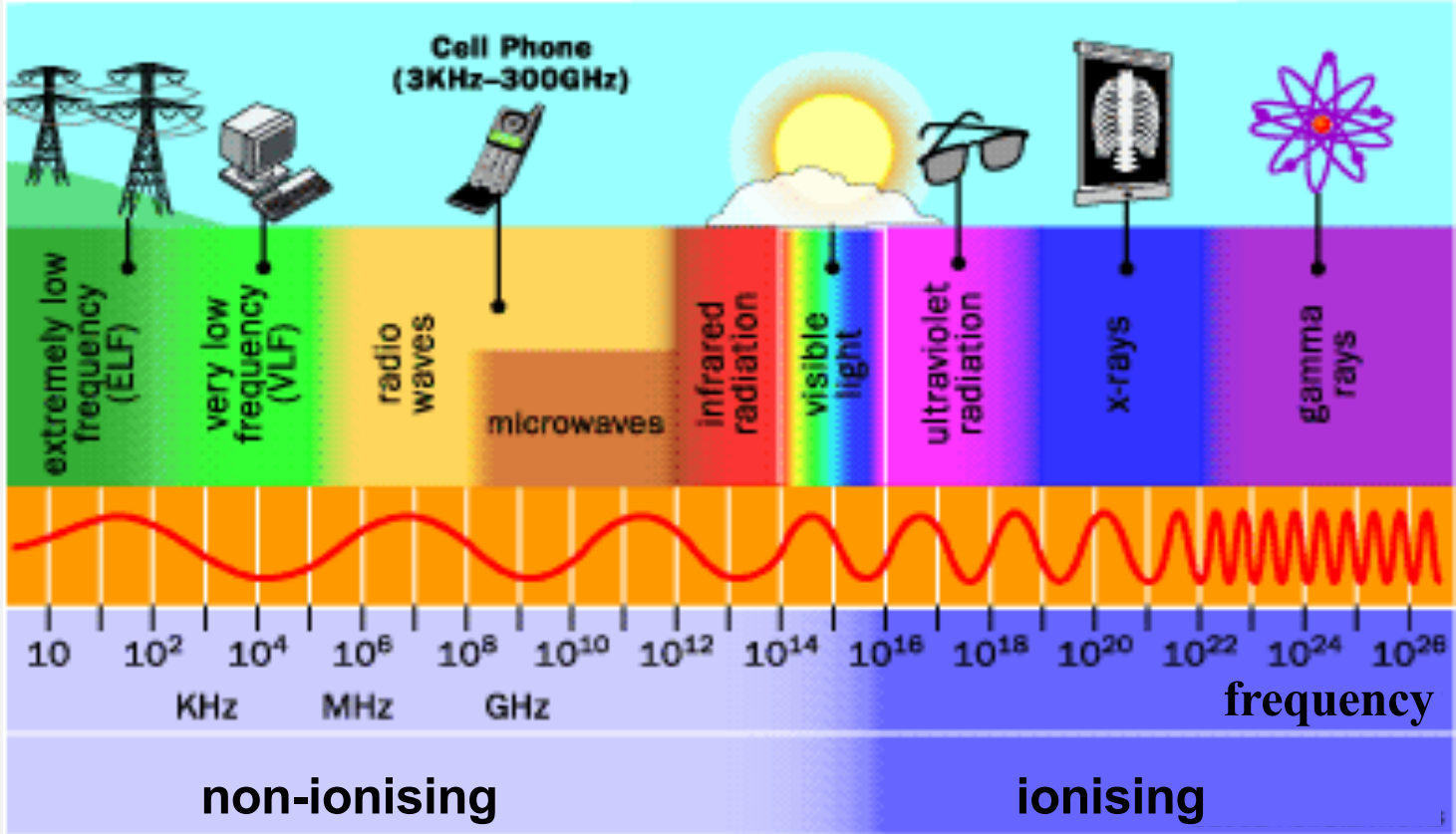

# Optical range

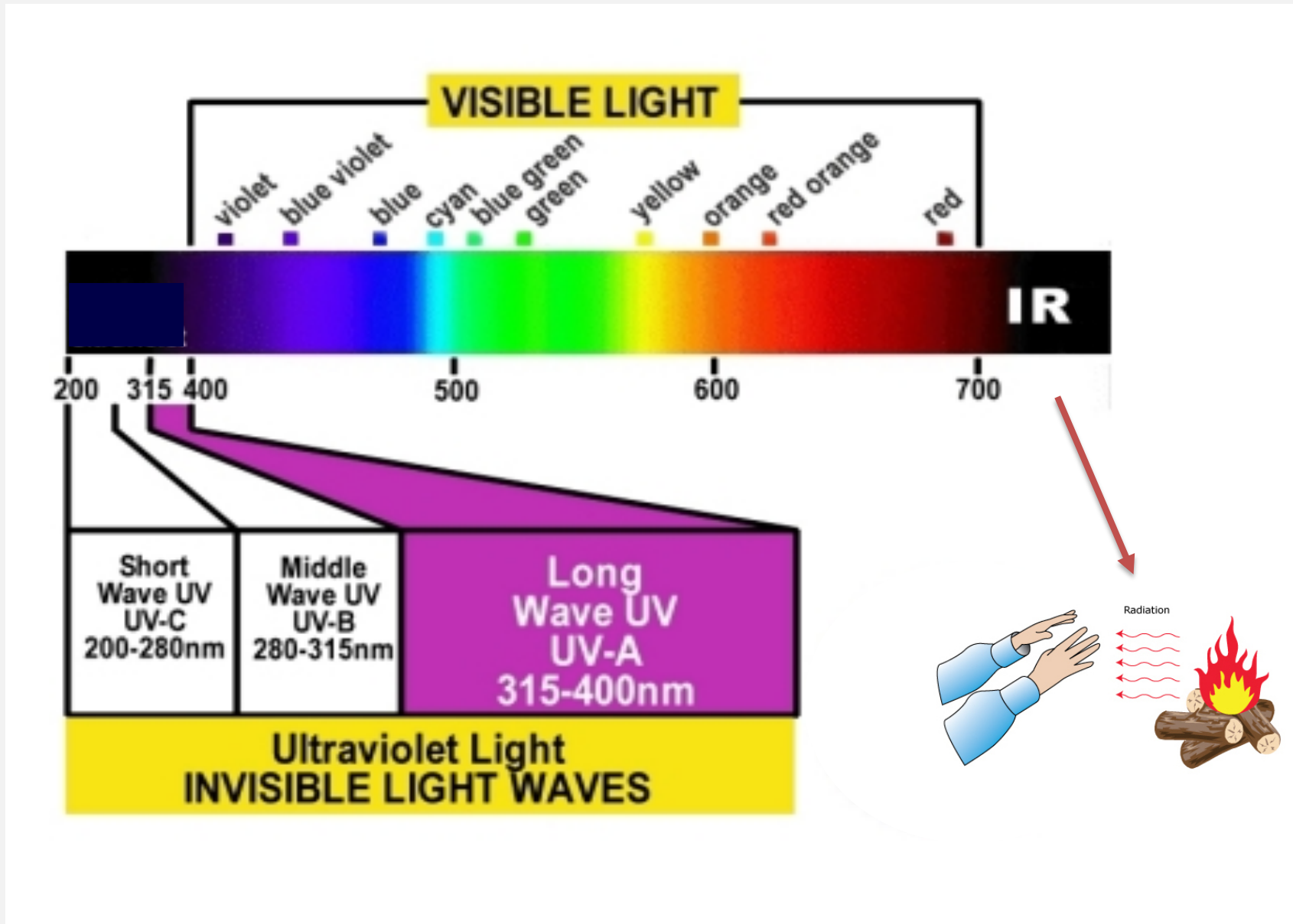

# Why only light could have dual nature?

Louis de Broglie's concept – the wave–particle duality:

All particles exhibit both wave and particle properties

Momentum of the electron:  $p = m_e v$

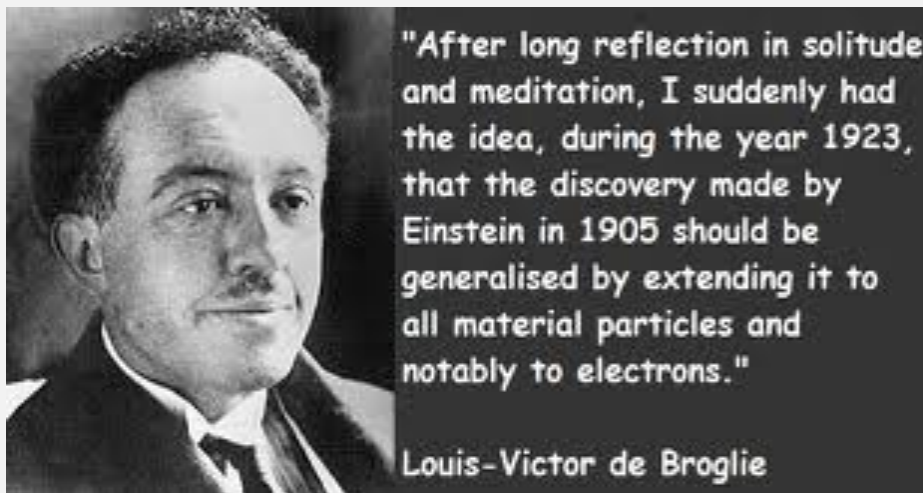

$$\lambda = h / p$$

Nobel prize in 1929

# Particles can behave as waves!

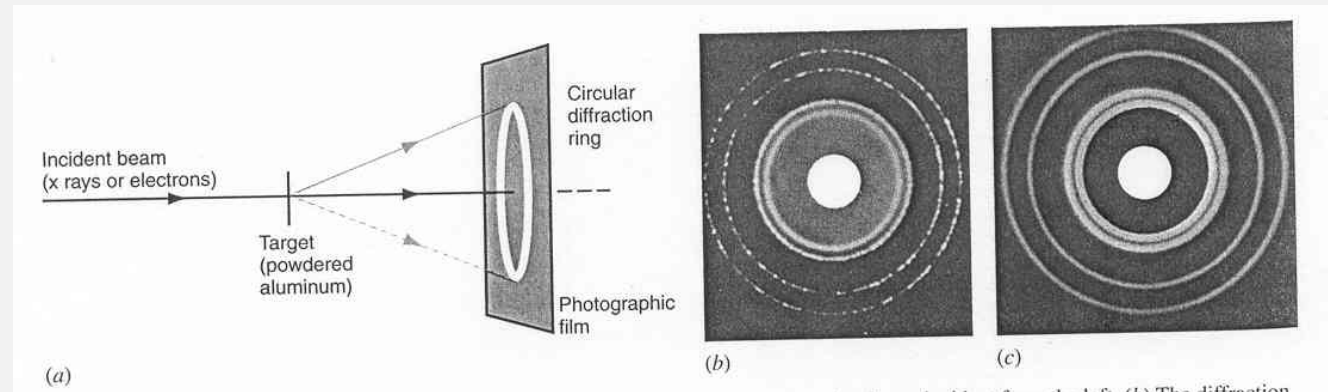

Electrons indeed behave exactly as if they were waves.



Clinton Joseph  
Davisson



George Paget  
Thomson

Nobel Prize in Physics 1937

*"for their experimental discovery of the  
diffraction of electrons by crystals"*

# Checklist

What is a radiation?

What are the parameters of waves?

What does the dual nature of light mean?

How can one prove the wave nature of light?

How can one prove the particle nature of light?

How can we give the energy of the photon?

What is a matter wave?

Measures and units

wavelength

frequency

energy

intensity

Related chapters in

*Damjanovich, Fidy, Szöllösi: Medical Biophysics*

II. 2. 1.

2.1.1

2.1.2

2.1.3

2.1.4

2.1.5

2.1.8