

**POLYMERIZATION, SELF-ASSEMBLY,
MECHANOENZYMES, PROTEIN FOLDING,
IRREVERSIBLE PROCESSES**

MIKLÓS KELLERMAYER

Polymerization

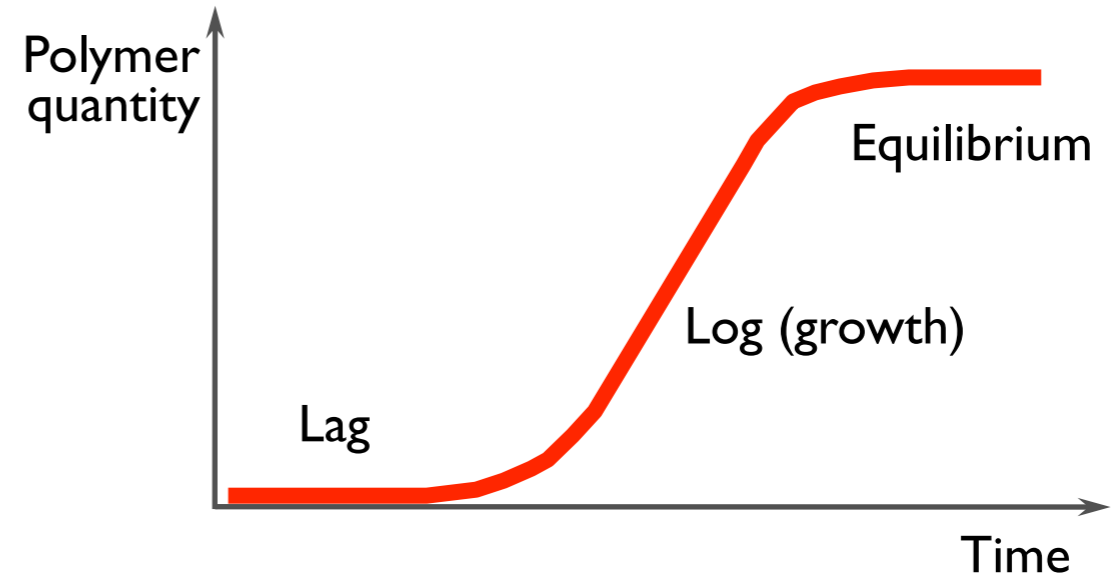

Polymerization equilibria

1. true equilibrium

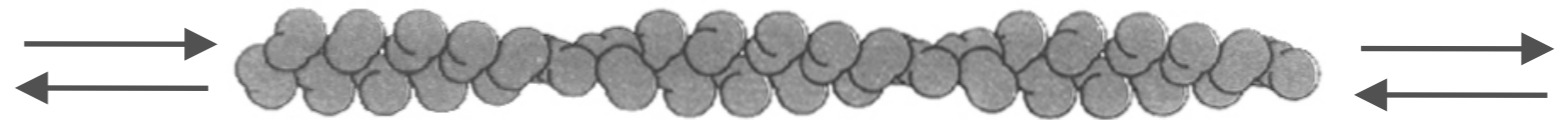

2. dynamic instability: slow growth followed by catastrophic depolymerization

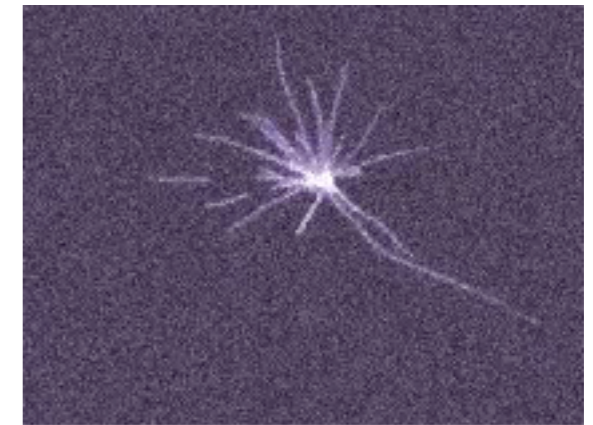

3. Treadmilling

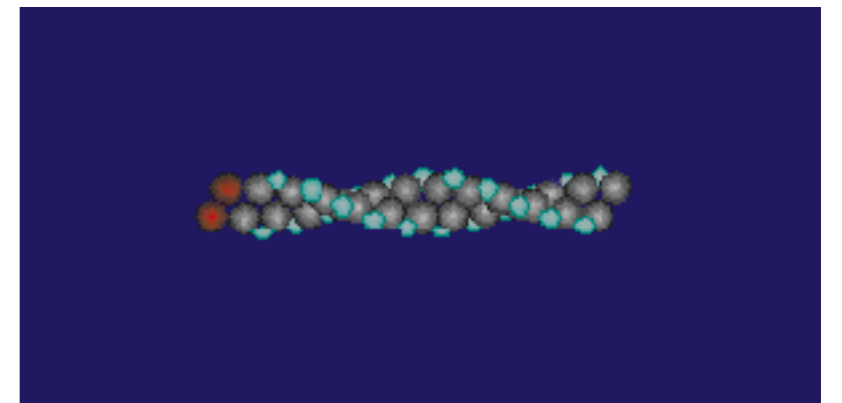
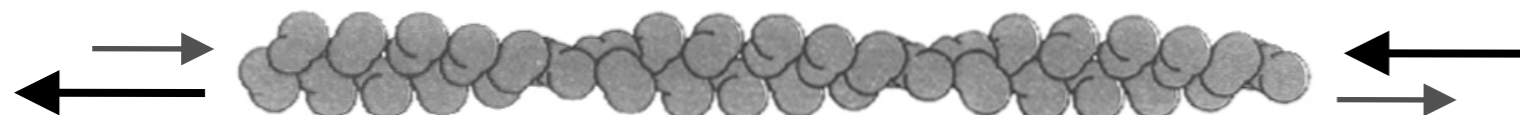

In vivo dynamic instability Microtubules

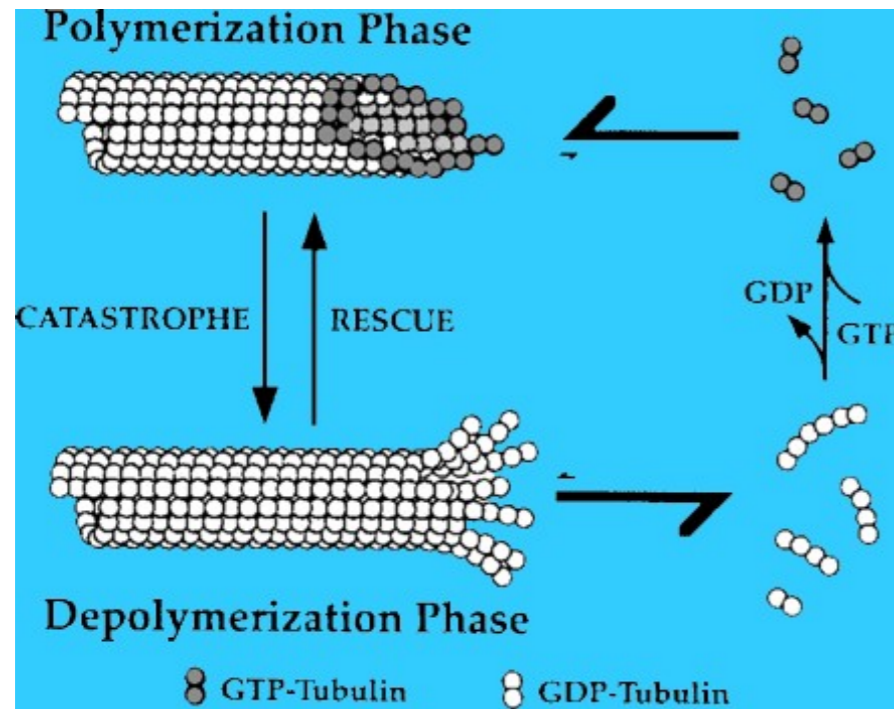

**CHO Cytoplasm
with
Centrosome**

In vivo treadmilling

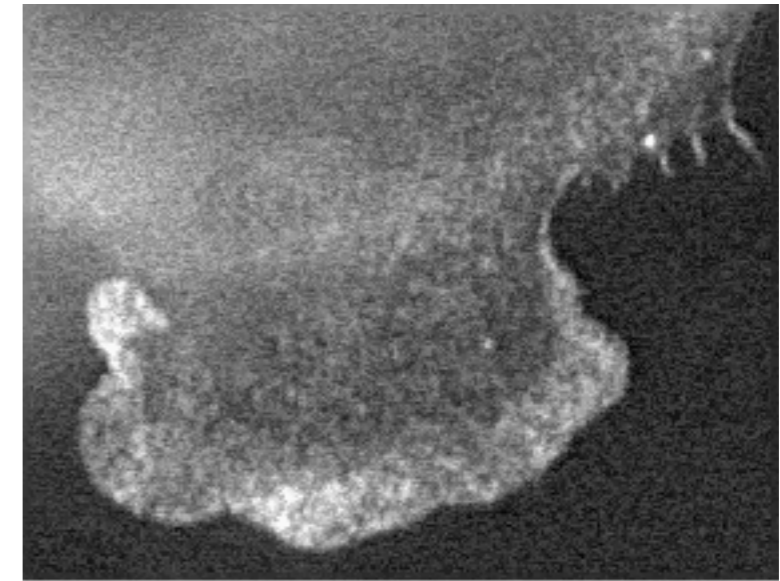

Actin
GFP-actin Speckle microscopy

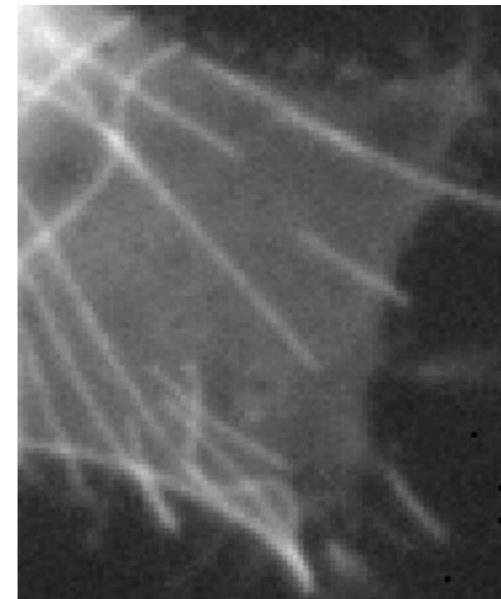

Microtubules

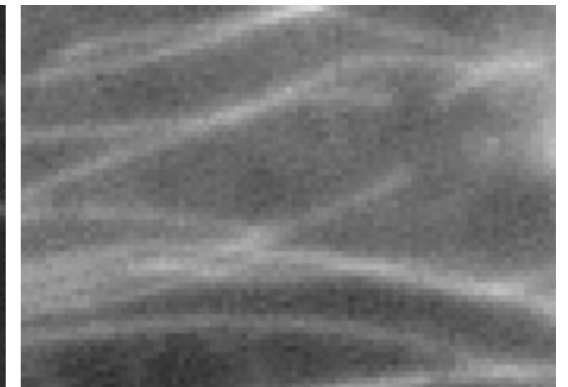

Motility with actin polymerization Intracellular pathogen motion



Listeria monocytogenes

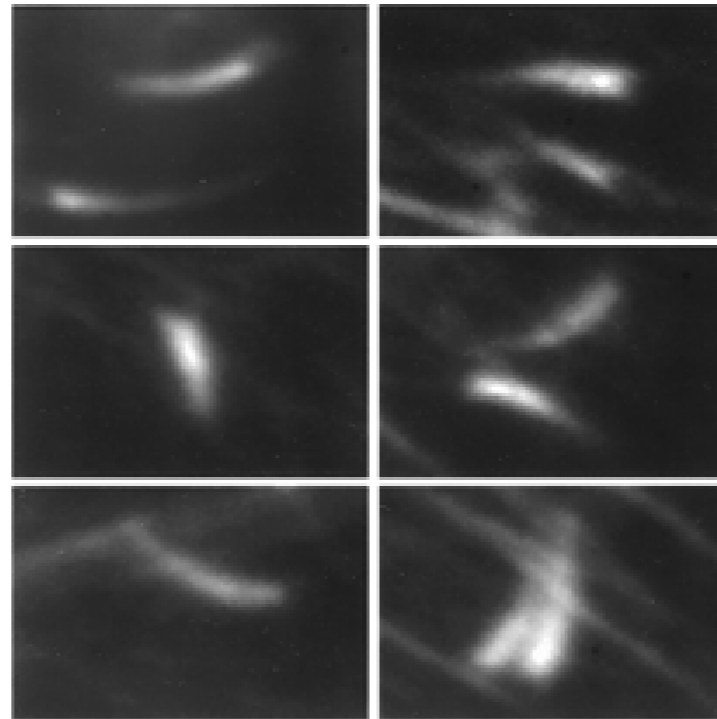

F-actin labeled with phalloidin

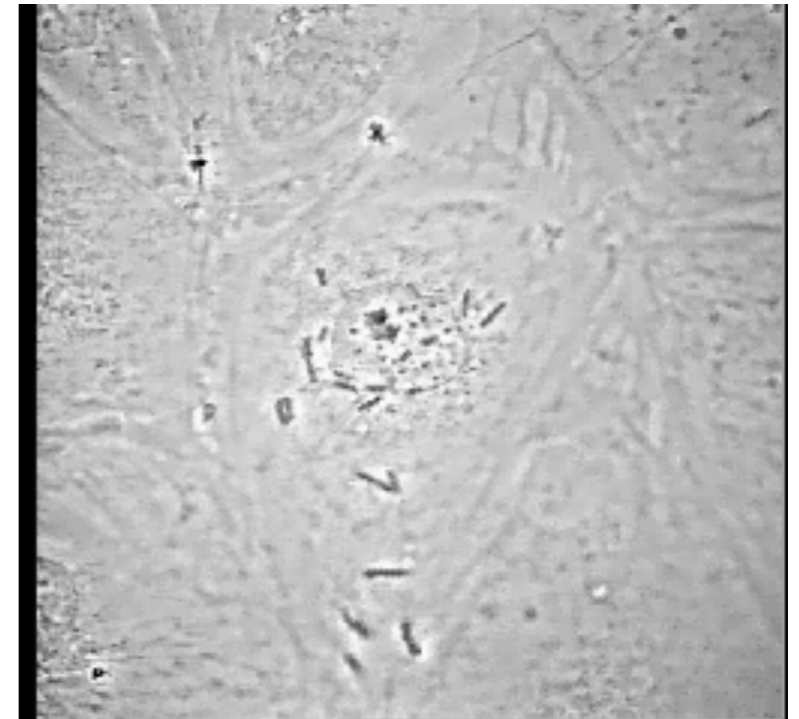

Shigella flexneri

Motility with actin polymerization

In vitro experiments



In Listeria Xenopus extract

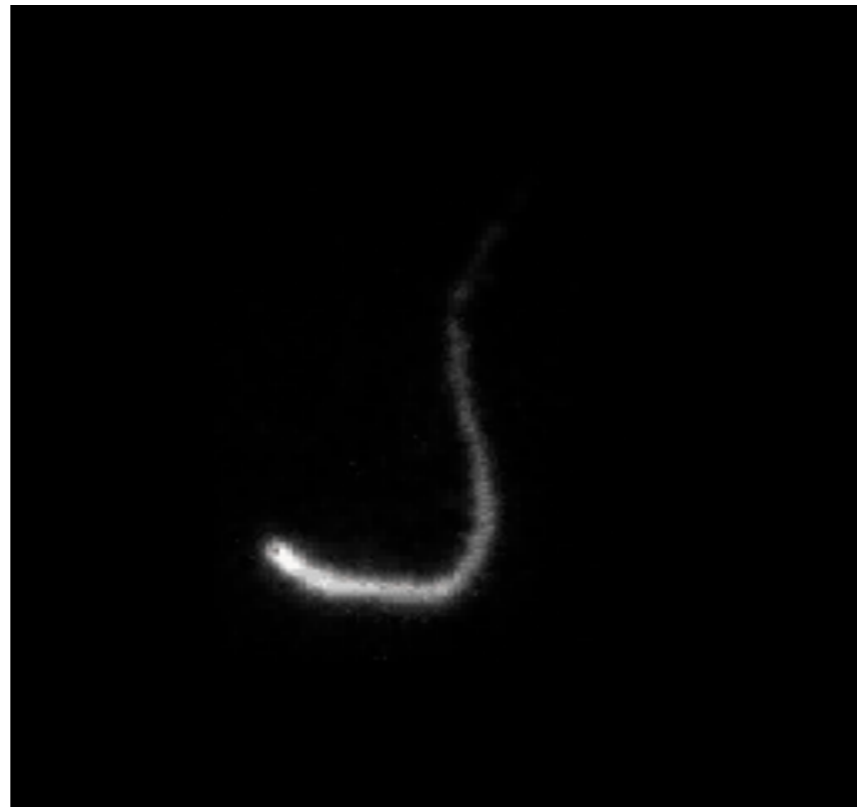

Microbead **asymmetrically** coated
with ActA in Xenopus extract

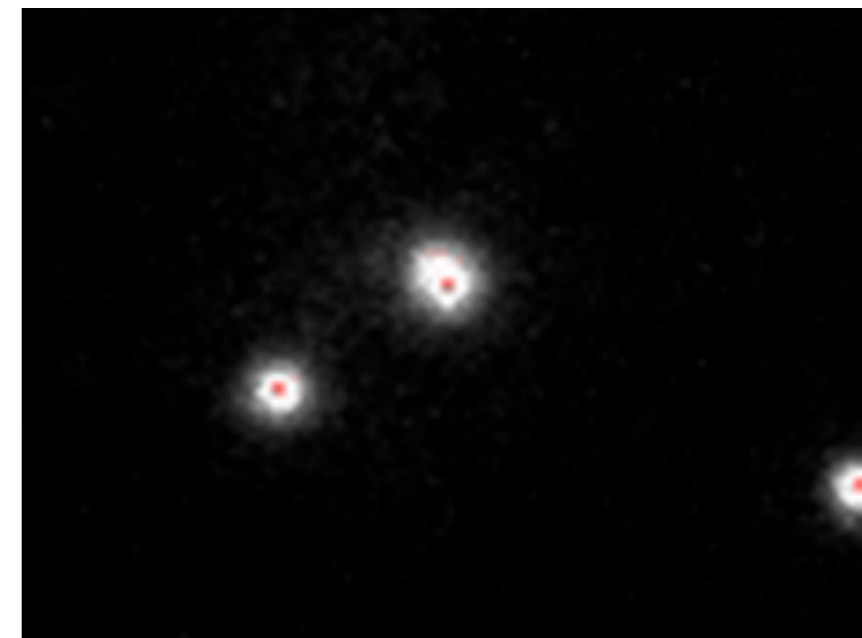

Microbead **symmetrically** coated
with ActA in Xenopus extract

ActA: A protein expressed by the bacterium *Listeria monocytogenes* that is responsible for the "rocketing" motility of the bacterium throughout the eukaryotic host cell. In addition to other host proteins, ActA binds actin directly.

A special case of diffusion: the Brownian ratchet

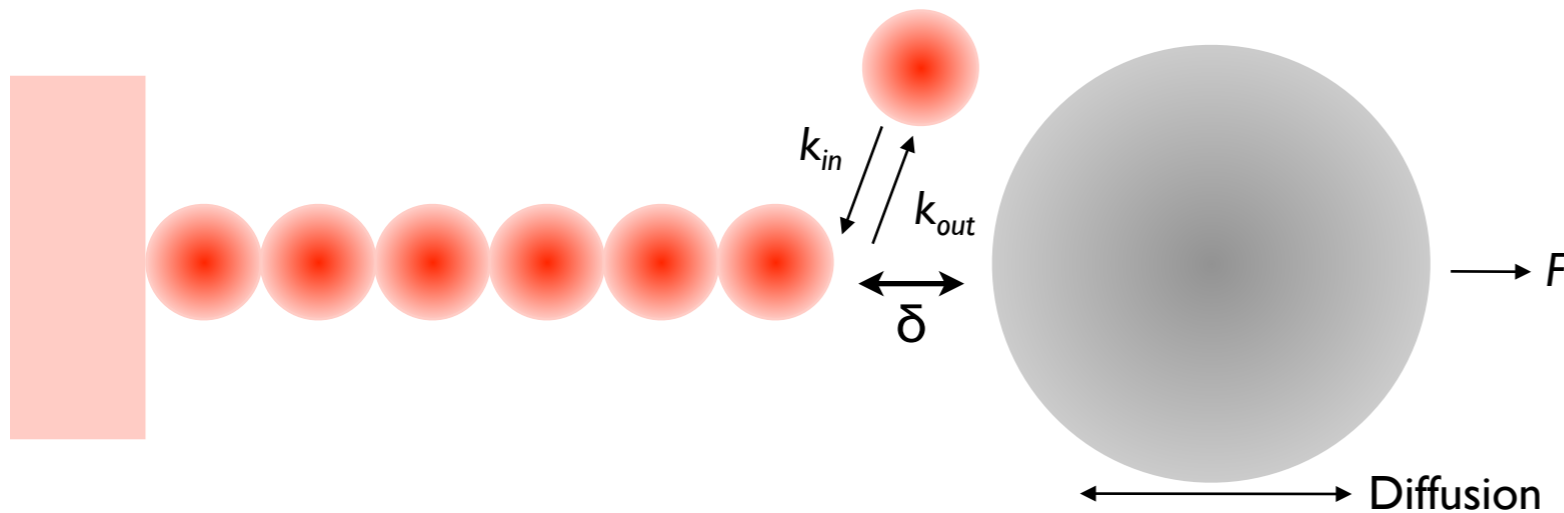
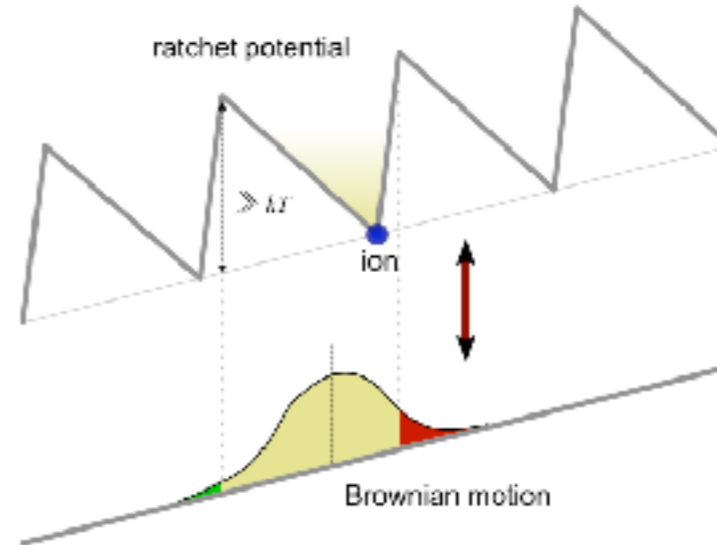
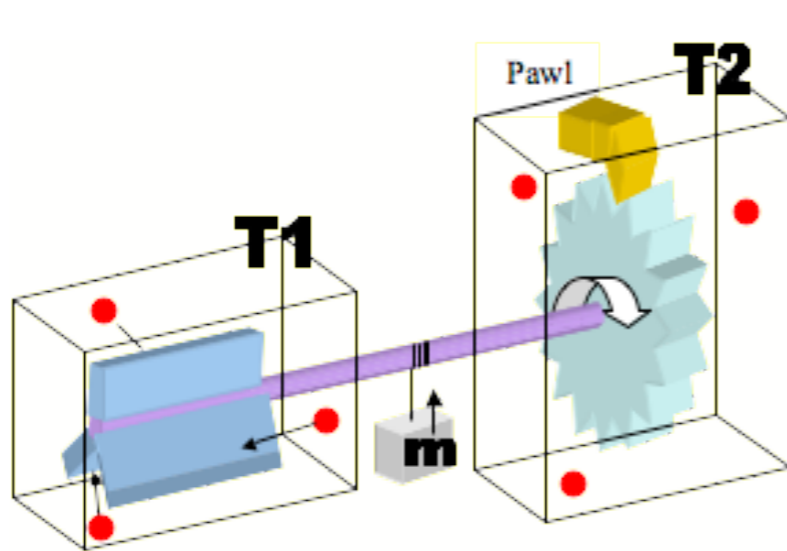

Listeria monocytogenes intracellular motion with actin polymerization

$$K(F) = K_c e^{\frac{F\delta}{k_B T}}$$

$K(F)$ = dissociation constant in the presence of force - monomer concentration at a net filament growth of 0.

K_c = critical concentration (at 0 force); F = force; δ = discrete growth upon the binding of one monomer. $k_B T$ = thermal energy.

N.B.: F may be + or -. The process may be **reaction driven** (too fast diffusion for k_{in}) or **diffusion driven** (too slow diffusion for k_{in}).

Force generation with polymerization

Force generation with depolymerization

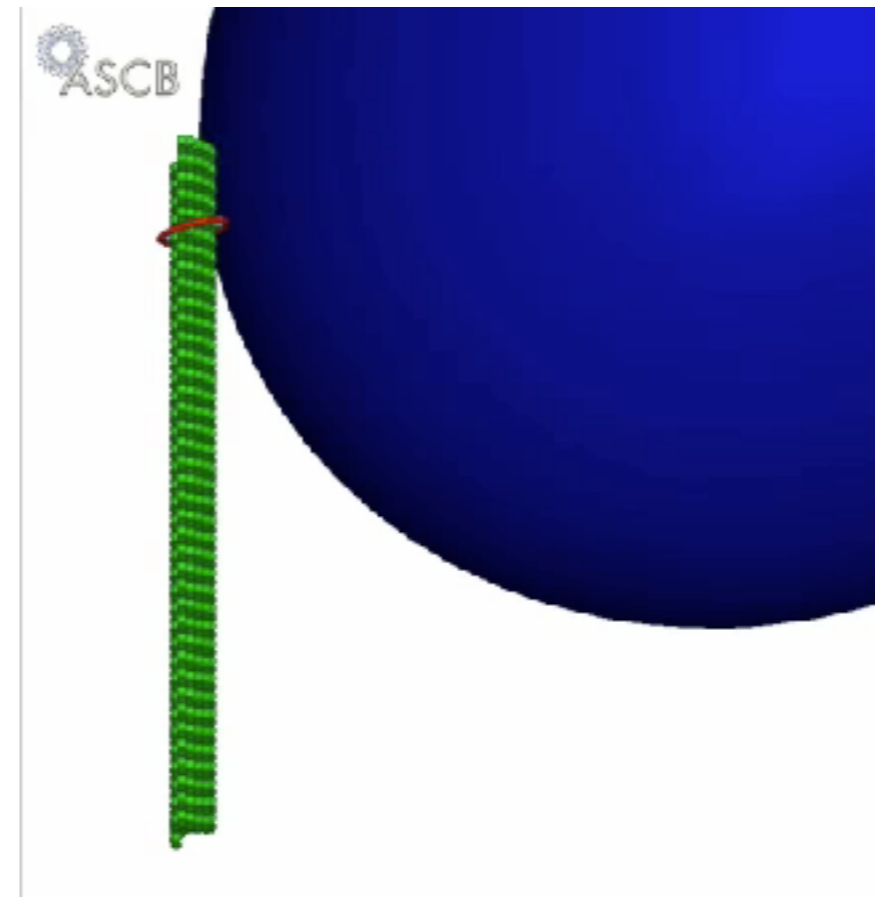
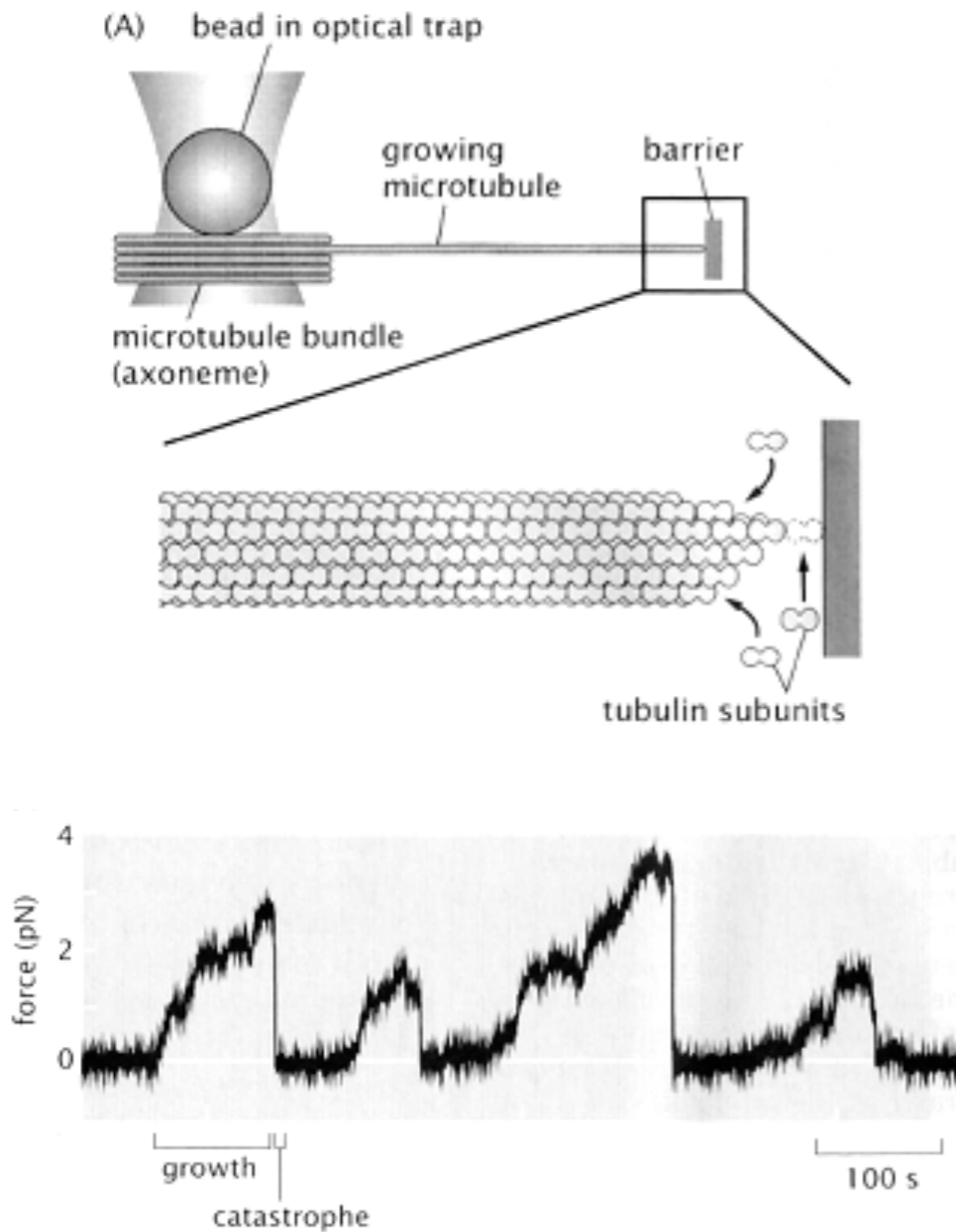

Vesicle transport with MT depolymerization

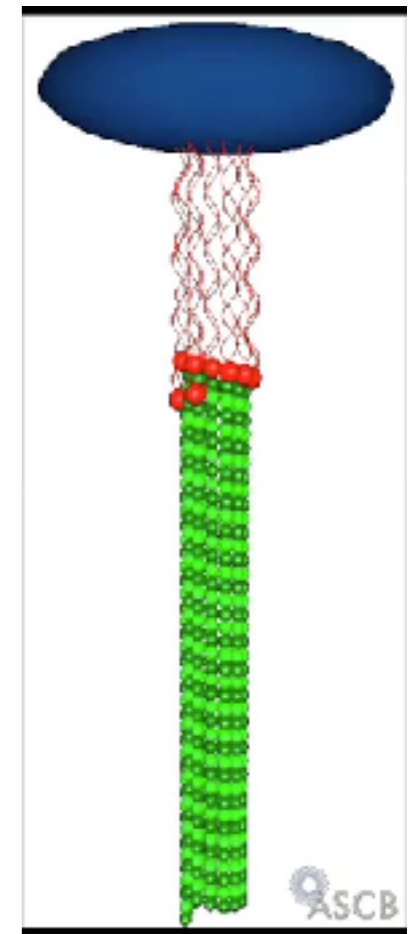

Chromosome (kinetochore) movement with MT depolymerization

MCAK: MT-depolymerizing kinesin

MCAK:

“Kinesin-13”

Binds to the plus (+) end of MT

Finds the + end with a diffusional search

Hydrolyses ATP

Controls MT depolymerization (“catastrophe factor”)

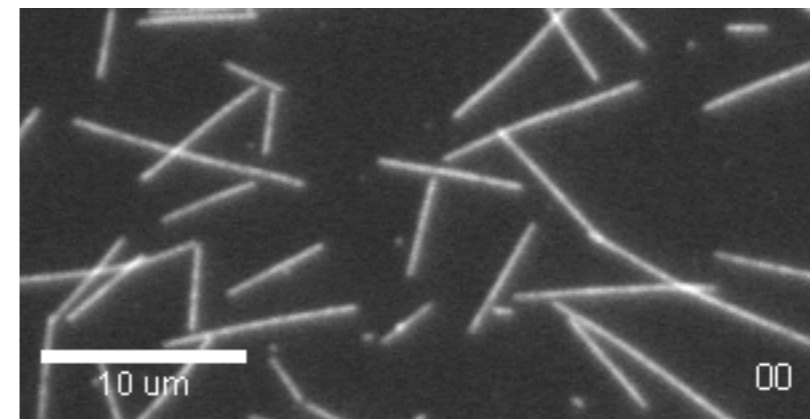
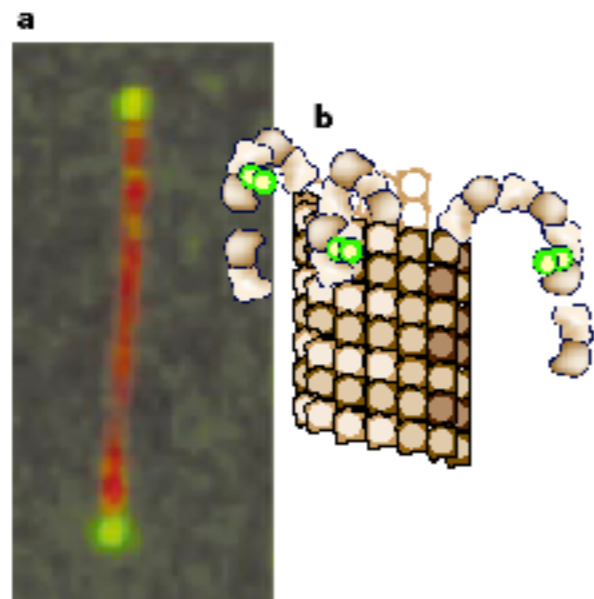

MCAK-induced MT depolymerization

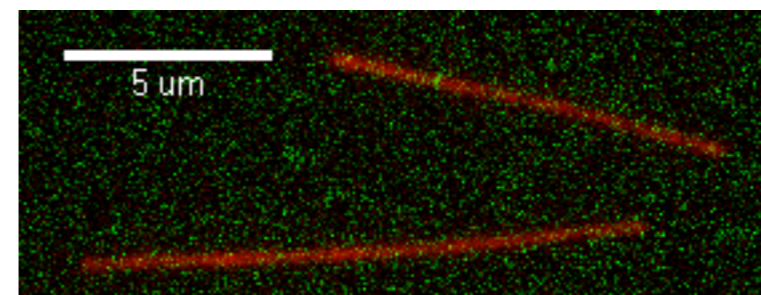
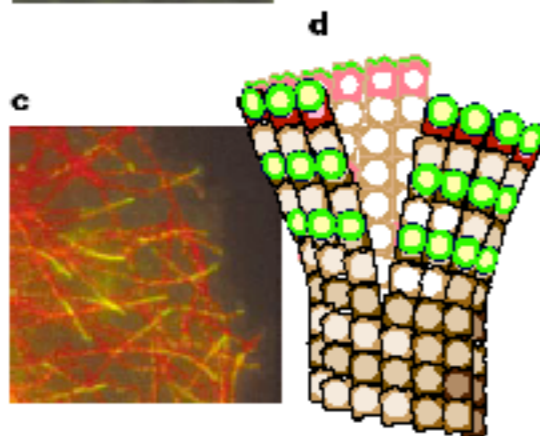

Diffusional search along MT (GFP-MCAK)

Self-assembly, catalyzed polymerization

Amyloid β -fibrils: components of Alzheimer plaques

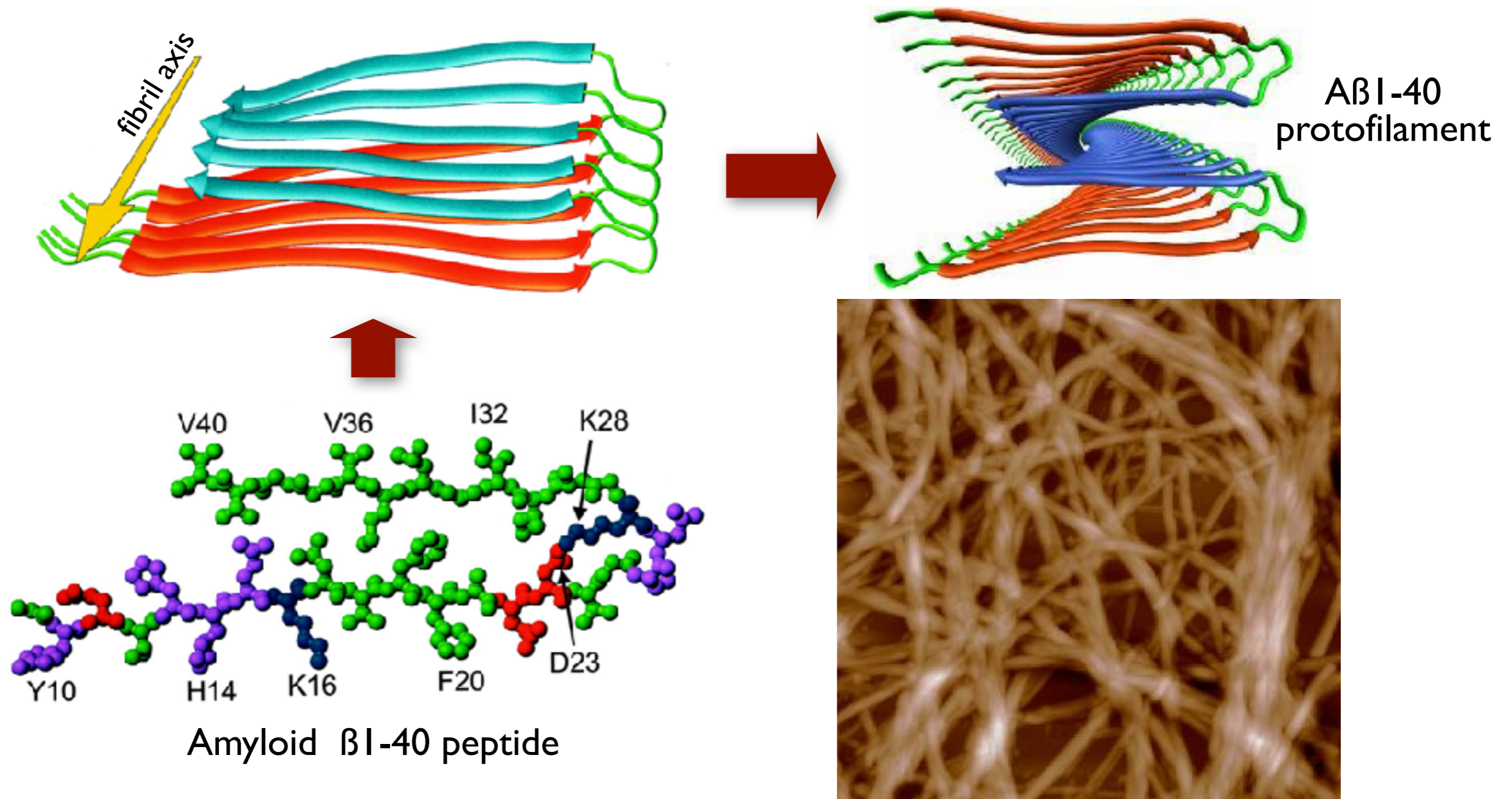

Fibrils grown from A β 1-40 peptide *in vitro* (AFM)

Epitaxial growth of amyloid fibrils

A β 1-40

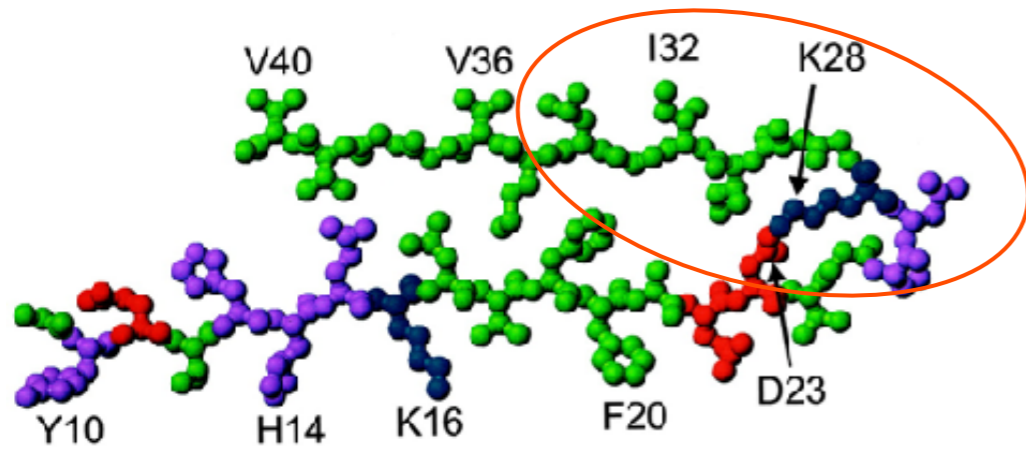

A β 25-35

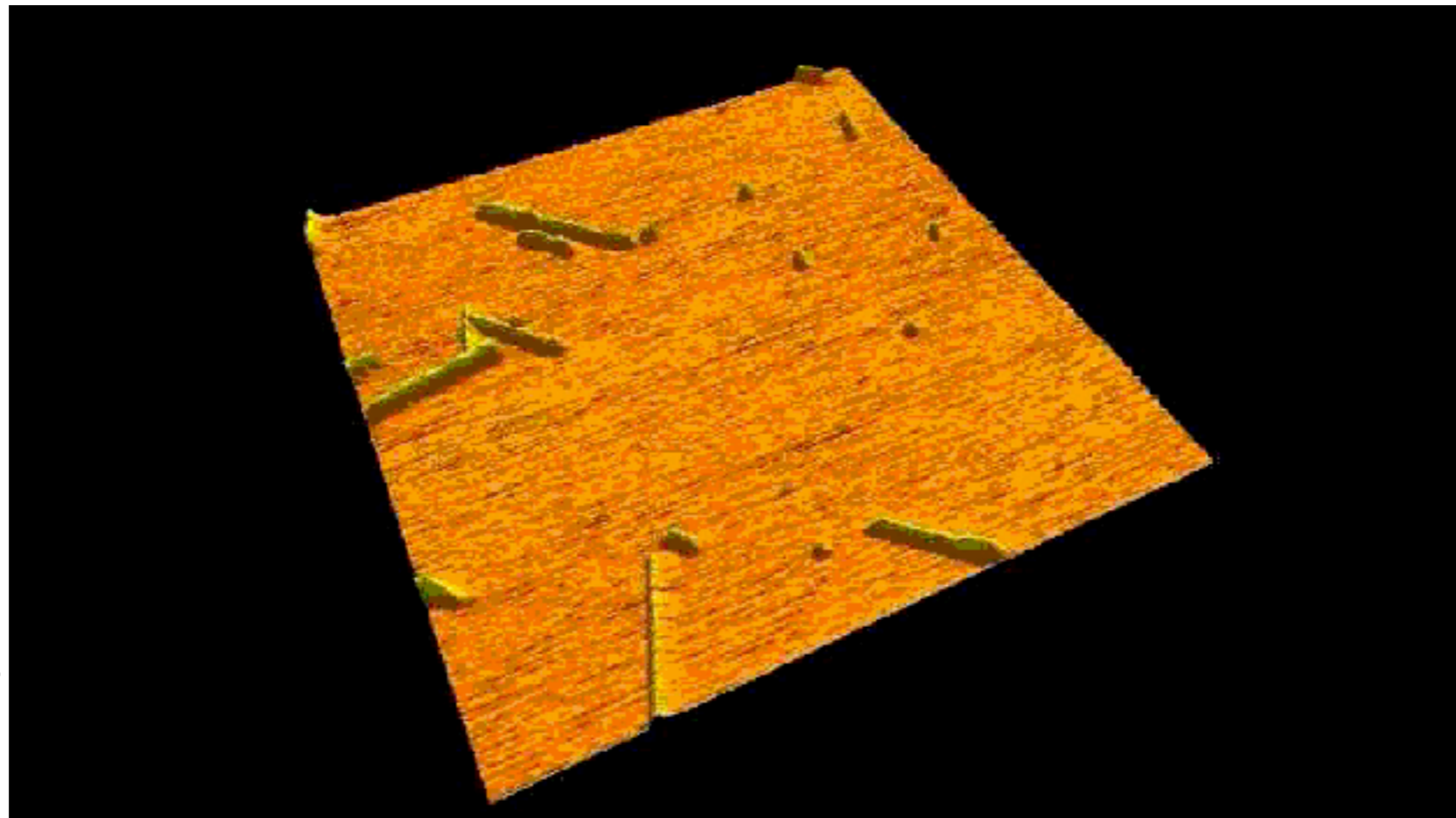
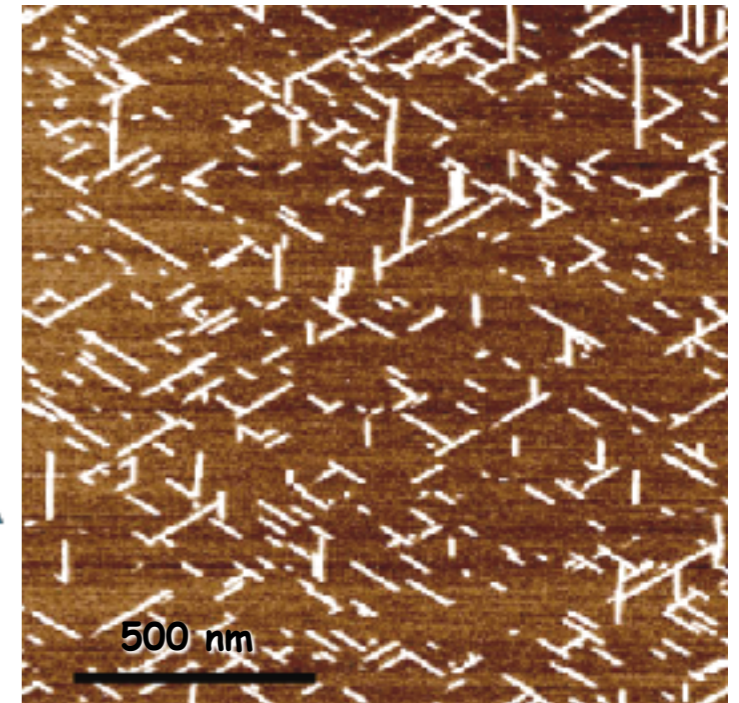
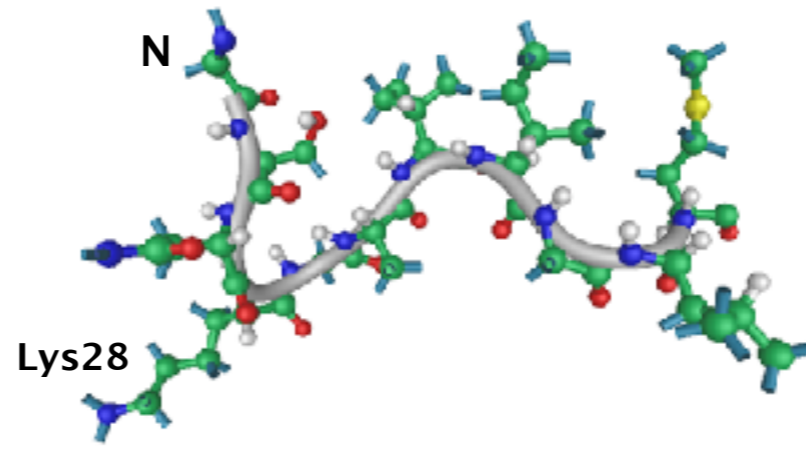

Epitaxial growth of
A β 25-35 fibrils on mica
surface

Nanoscale mechanism of catalyzed fibril growth: scanning probe kymography

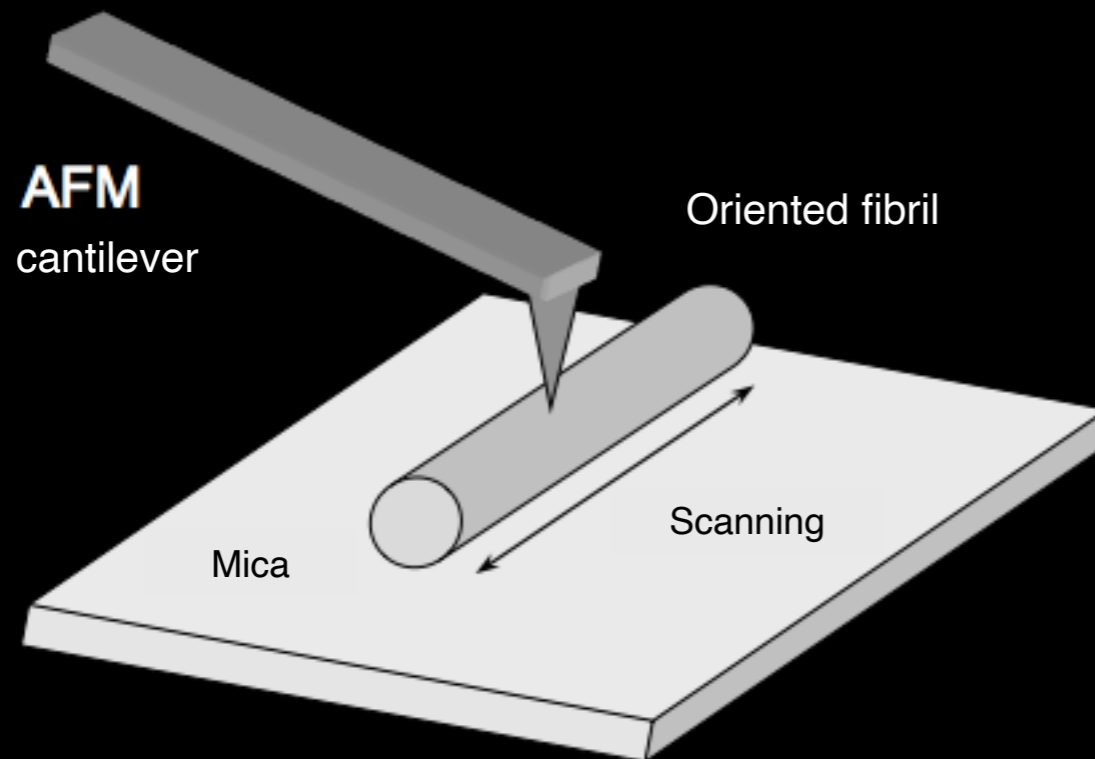
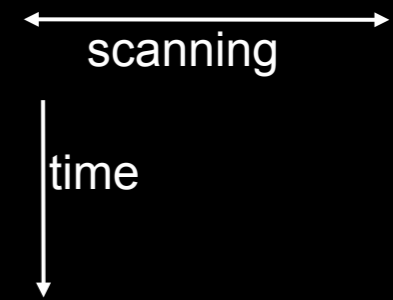

Spatial
resolution:
1 nm

Temporal
resolution:
300 ms

Scanning probe kymography

Space domain

Vertical scanning turned off

Time domain (20 min)

Start

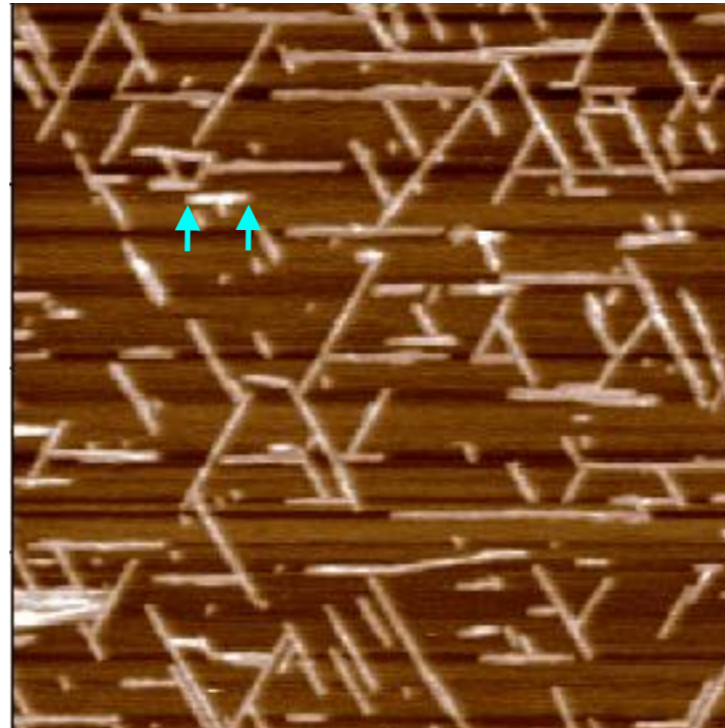

Stop

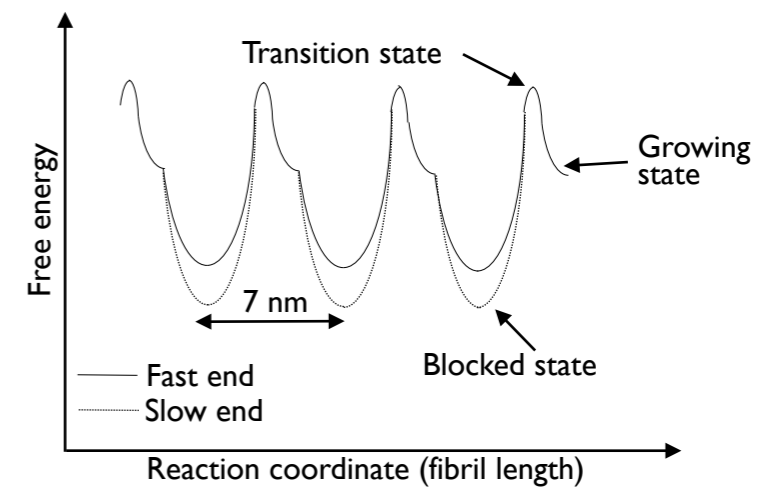
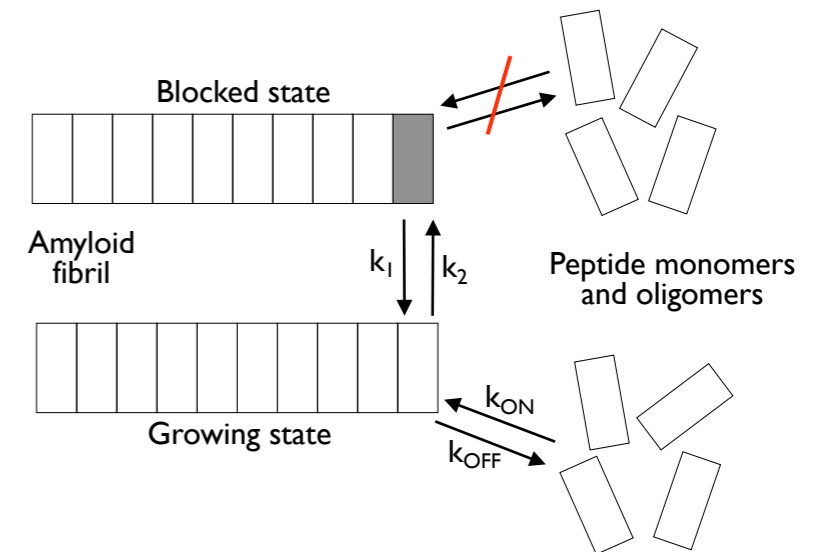
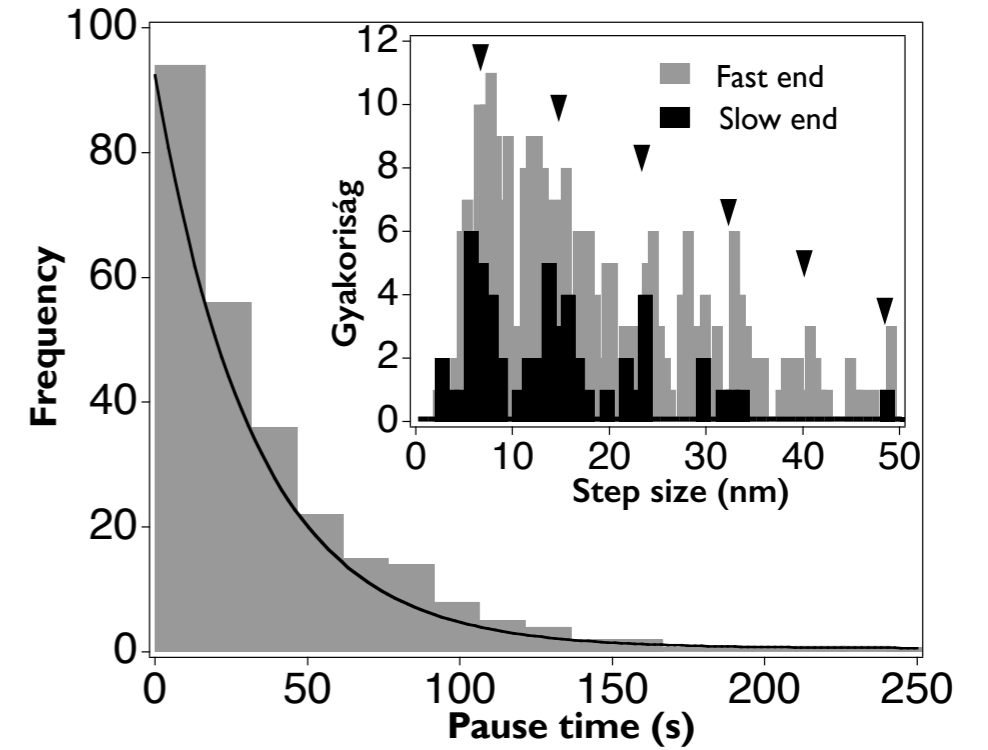
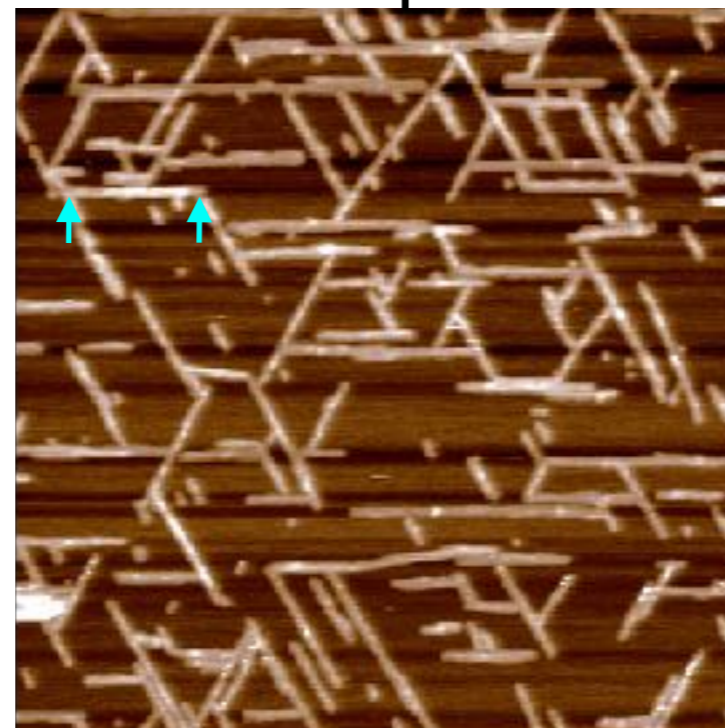

Motor proteins

(introduced last semester)

1. Bind to specific filaments
(cytoskeleton, DNA, RNA)
2. Generate force and displacement (or torque)
3. Convert chemical energy to mechanical (directly, not through heat conversion)

Types of motor proteins

1. Actin based

Myosins: Conventional (myosin II) and non-conventional Myosin superfamily (I-XXIV classes). Move towards plus end.

2. Microtubule based

a. Dyneins: Ciliary (flagellar) and cytoplasmic dyneins. Move towards the minus end along the microtubule.

b. Kinesins: Kinesin superfamily: conventional and non-conventional. Move towards the plus end along the microtubule.

c. Dynamins: MT-dependent GTPase activity
Biological role: vacuolar protein sorting (pinchase enzymes)?

3. DNA based motors

DNA and RNA polymerases, virus capsid packaging motor, condensins
Produce force and displacement along the DNA strand

4. Rotary motors

F1F0-ATP synthase
Bacterial flagellar motor

5. Mechanoenzyme complexes

Ribosome

Cyclic mechanism - “duty cycle”

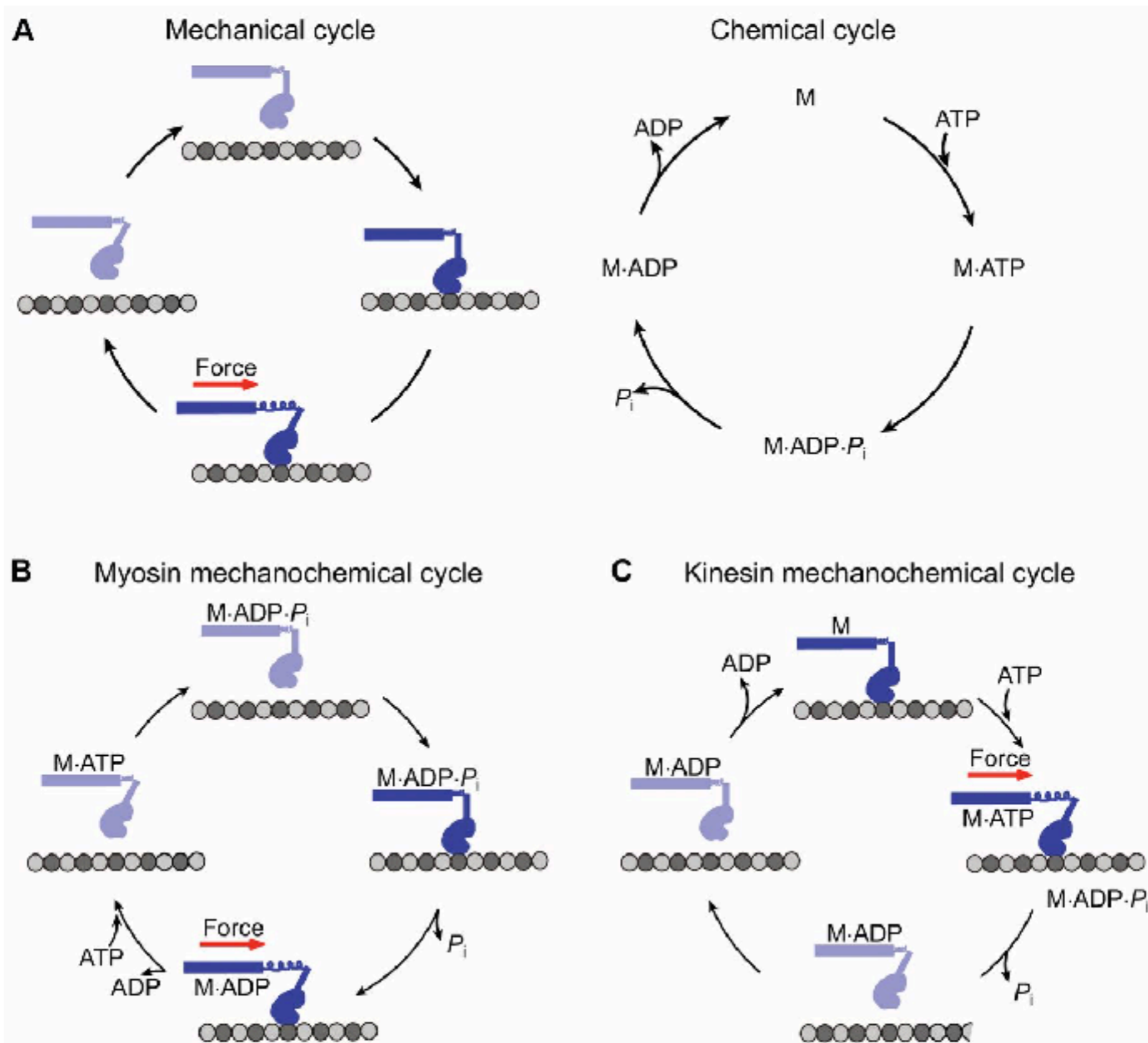

Myosin

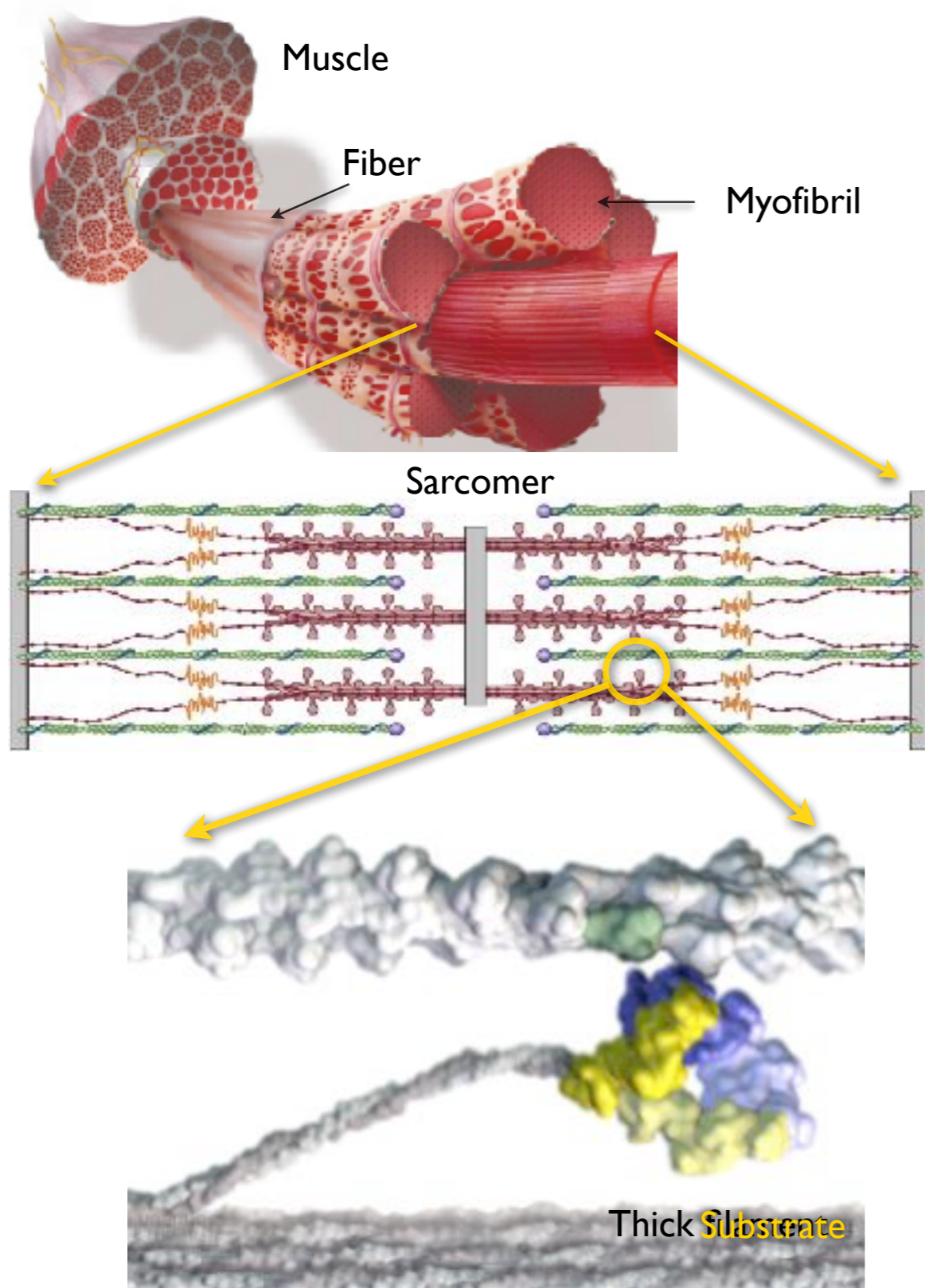

The myosin superfamily

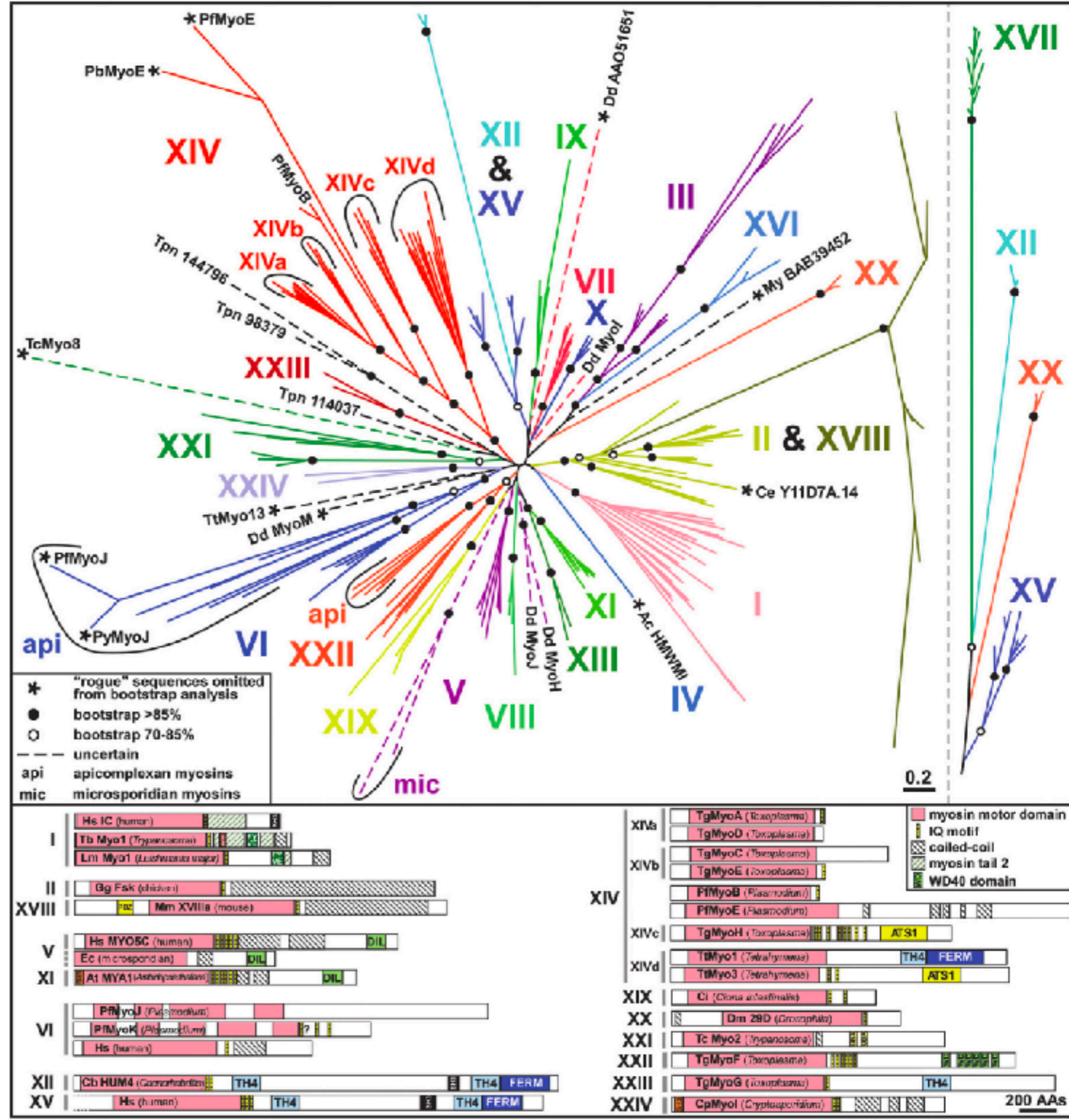

Functions of the myosin superfamily

Myosin structure and motility

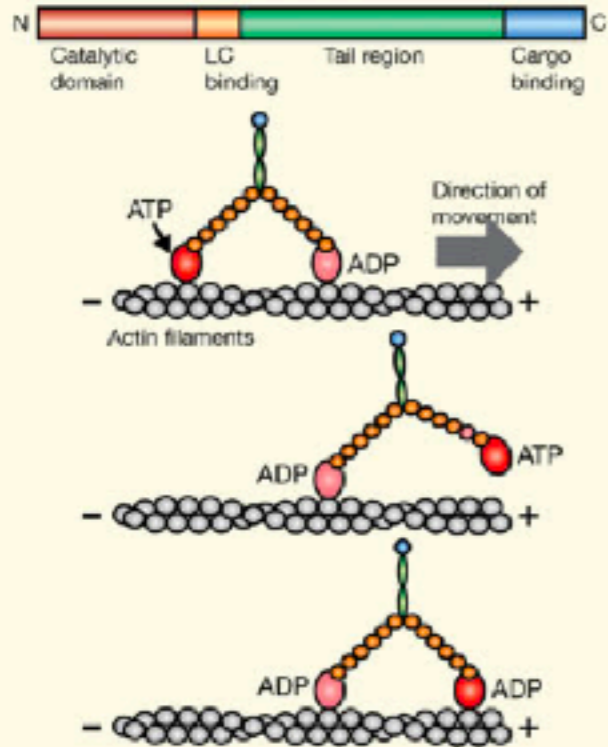

Cargo interactions

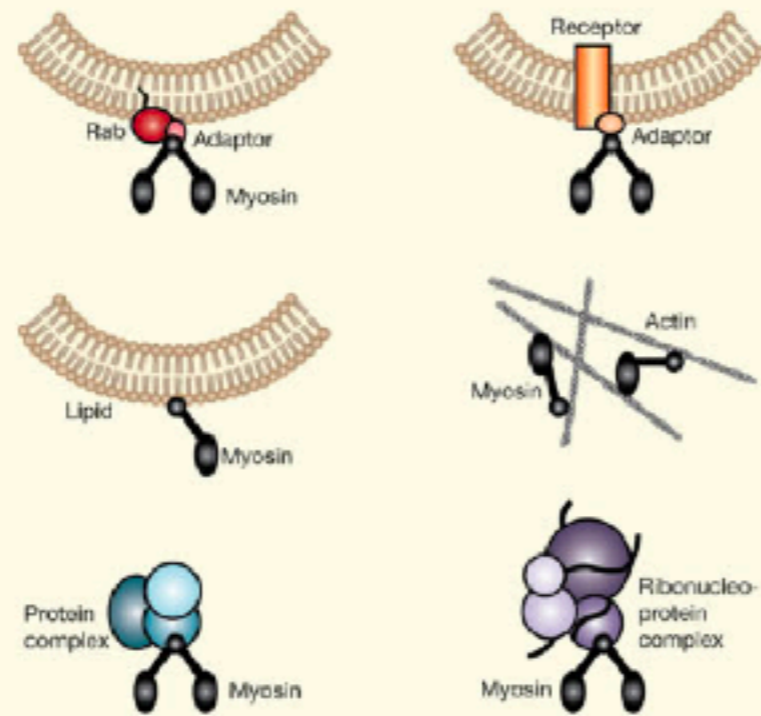

Actin-based projections

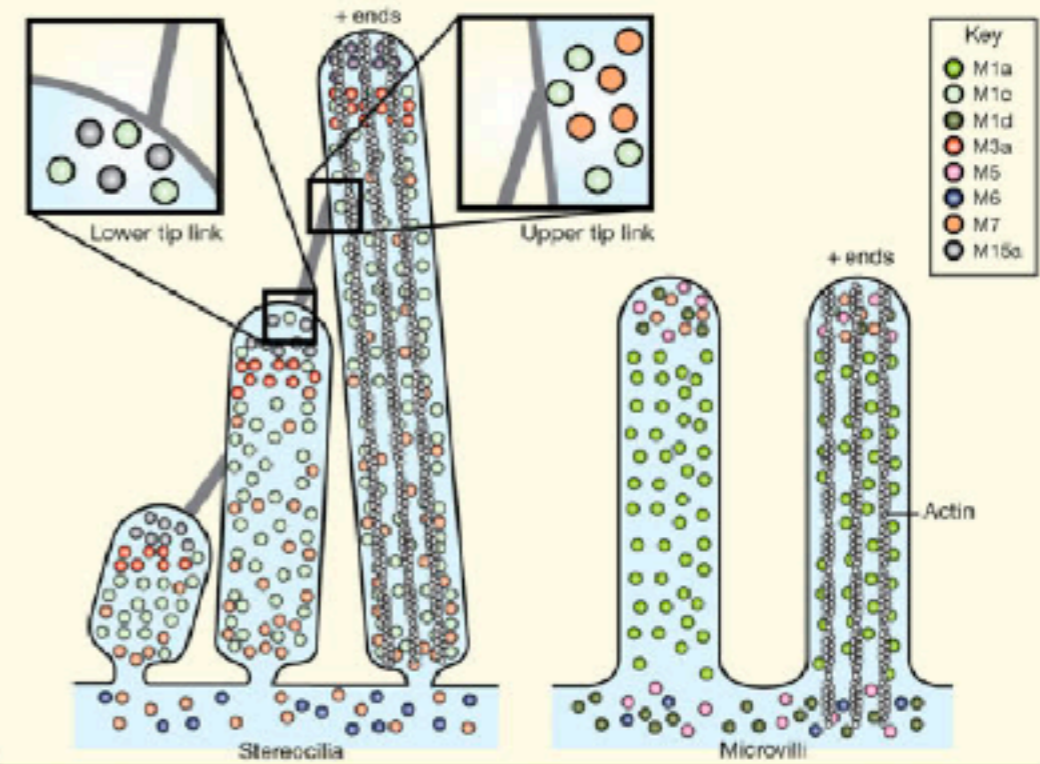

Membrane compartments

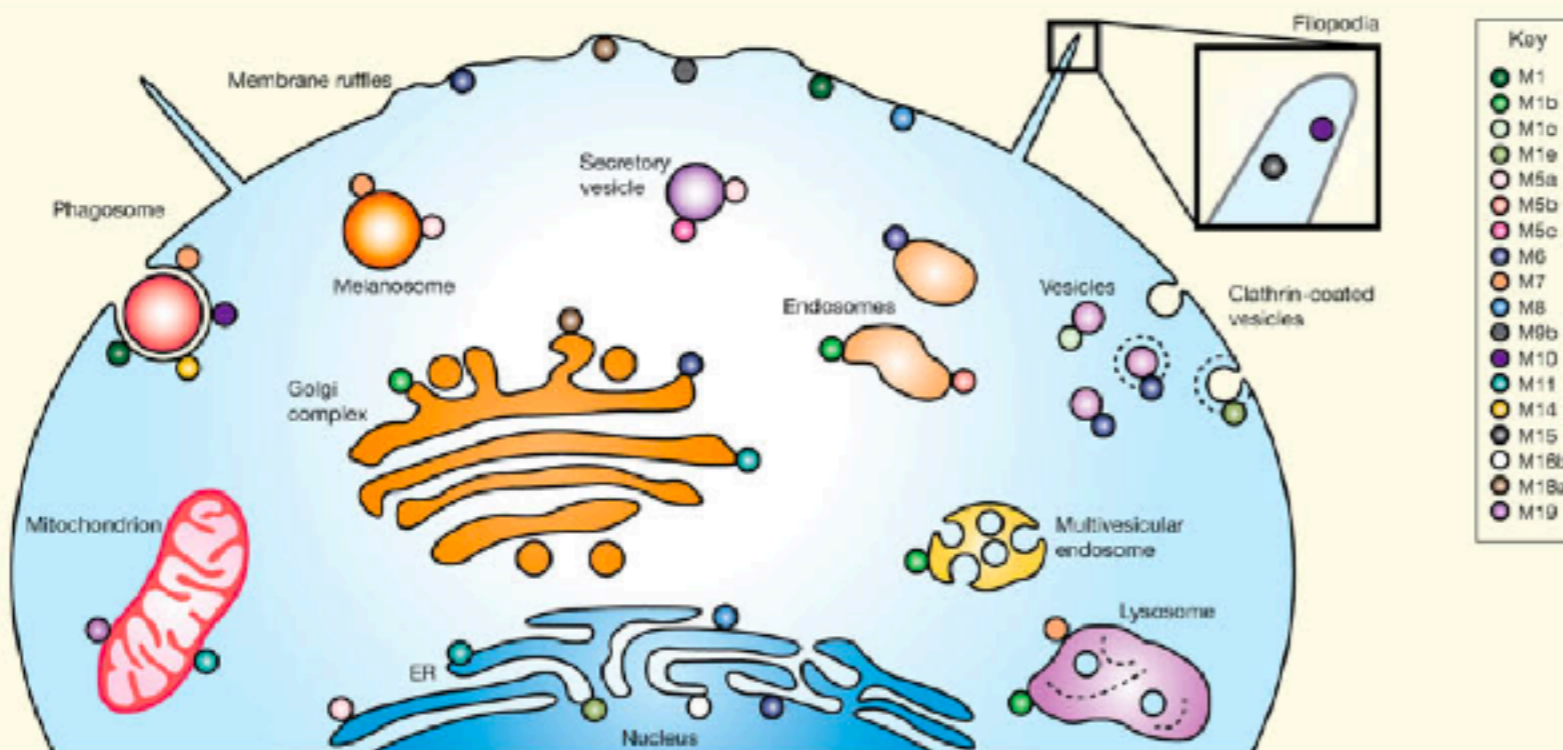

Muscle contraction

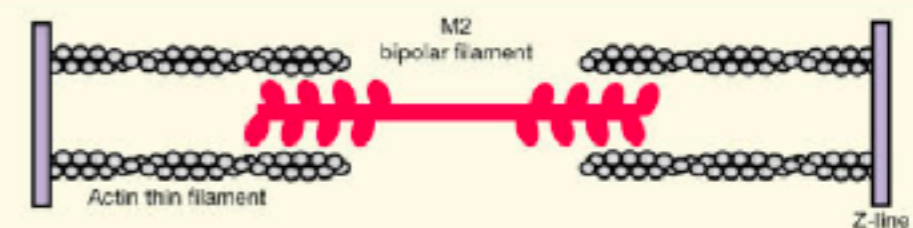

Cell division

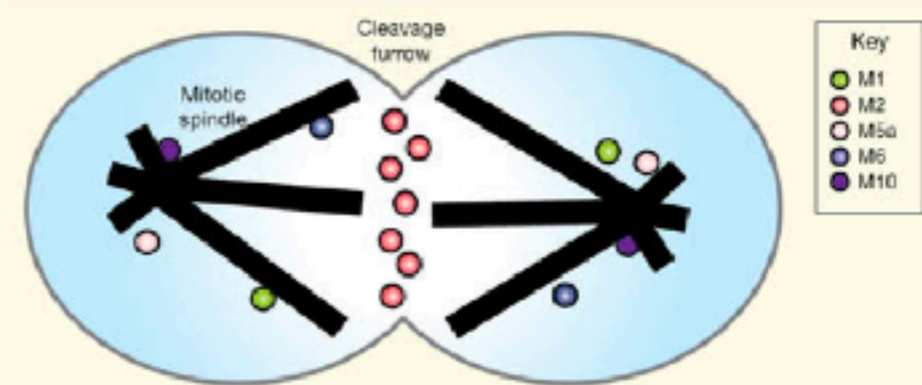

Myosin II

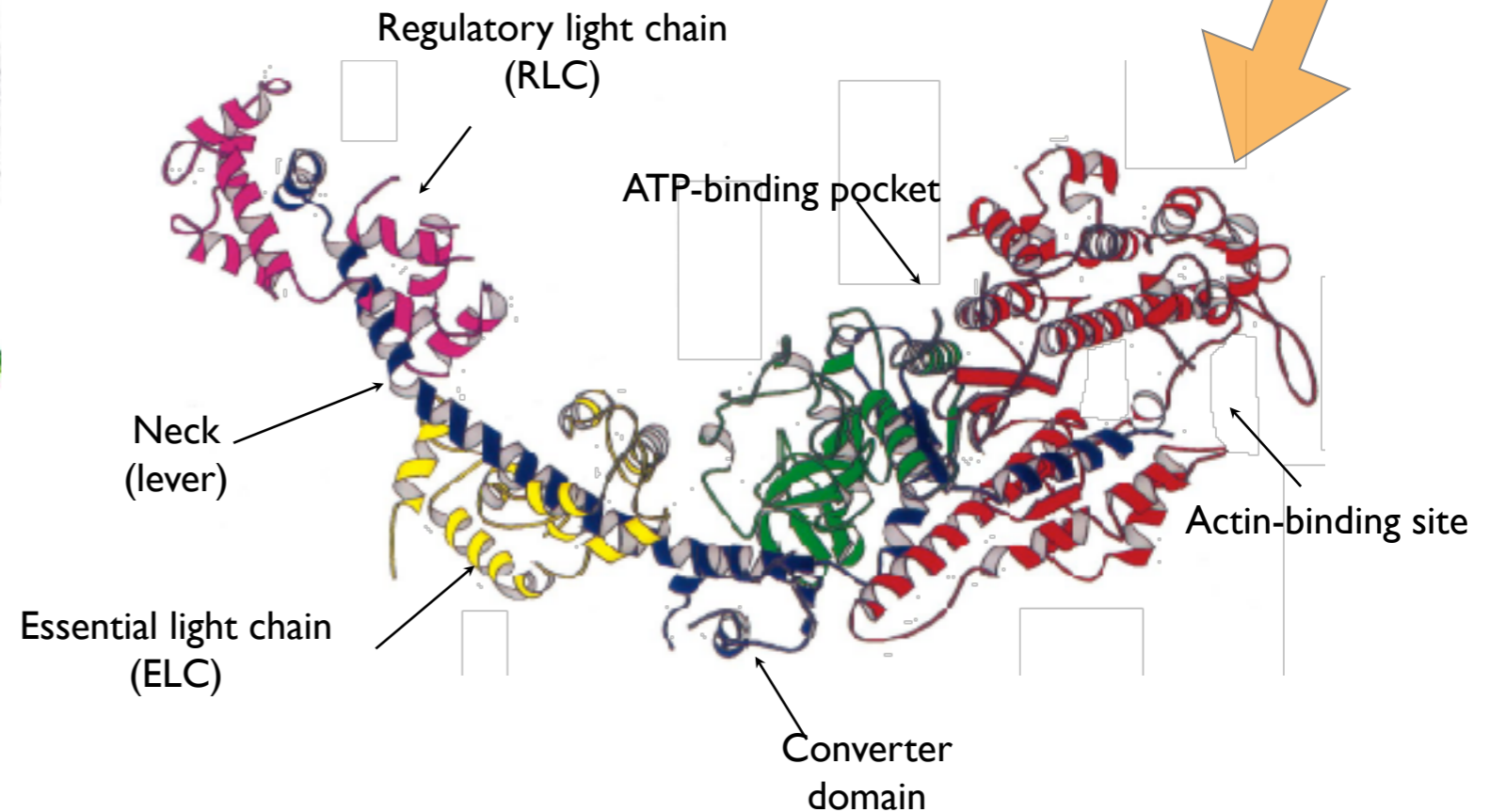
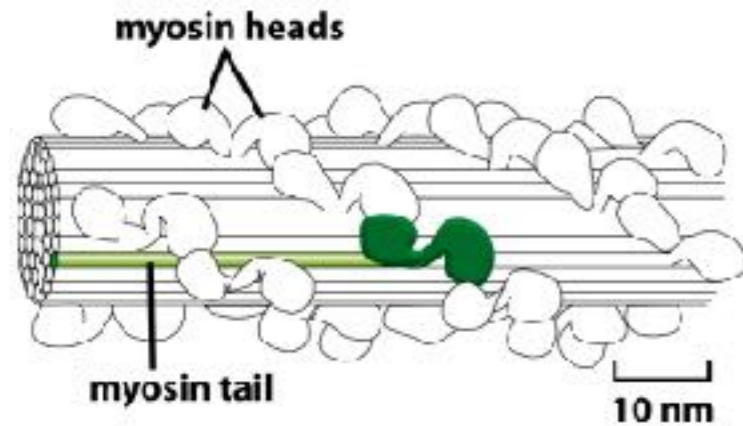
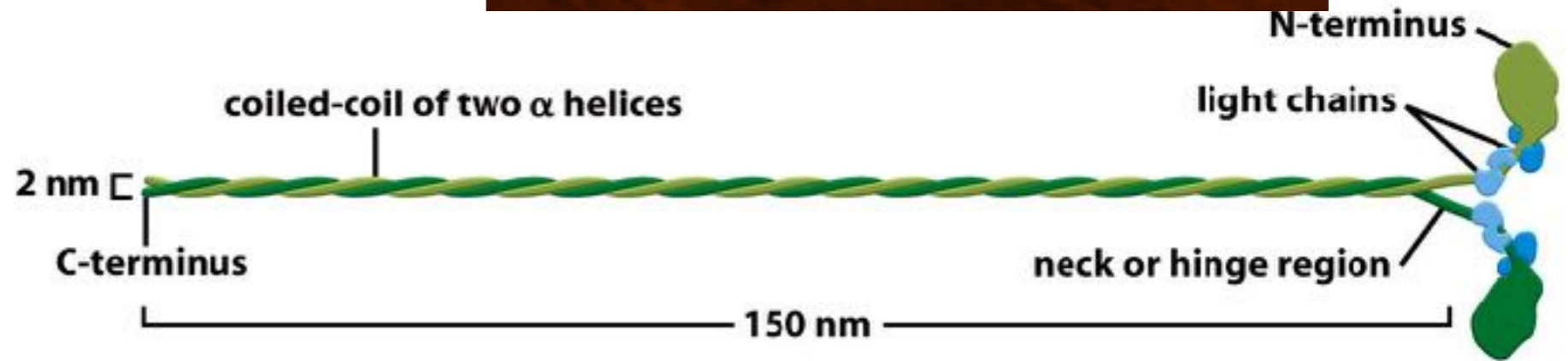
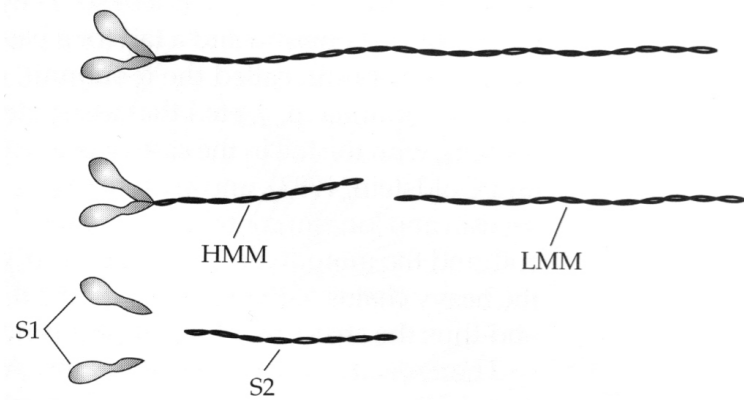
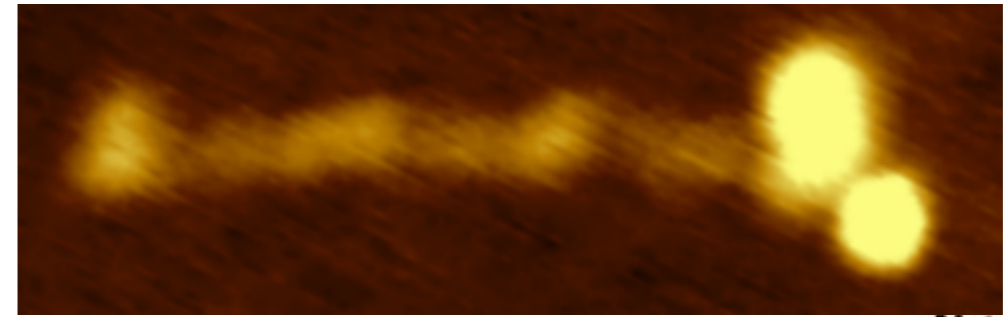
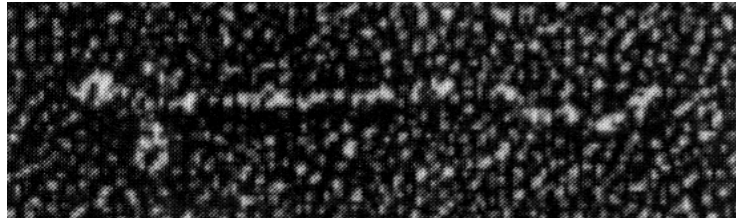

Myosin II assembles into thick filaments

Two-photon microscopic image of a muscle fiber

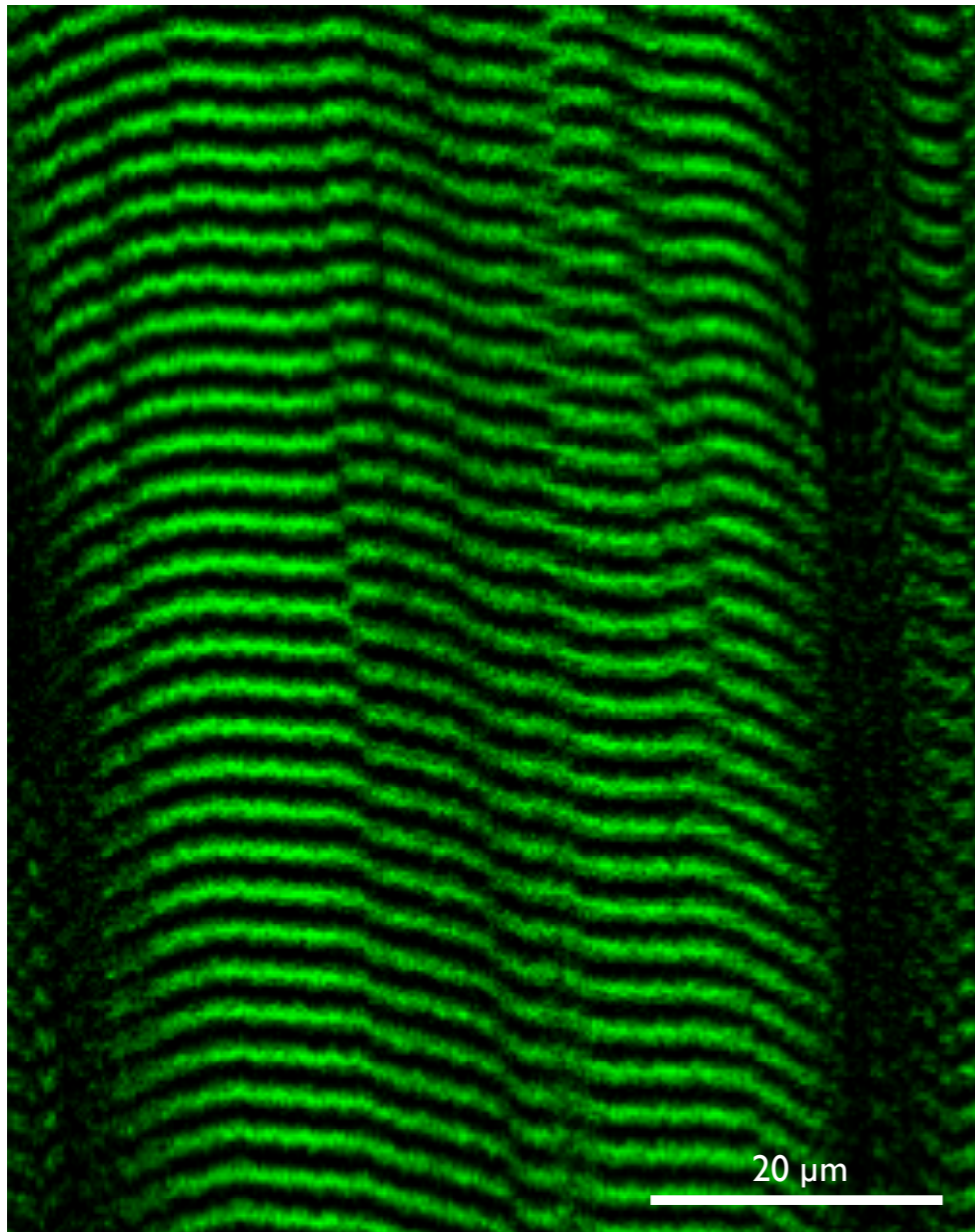

Signal source:
helical
structure of
myosin
filaments

Excitation:
1000 nm

Second
harmonic
generation
(SHG):
500 nm

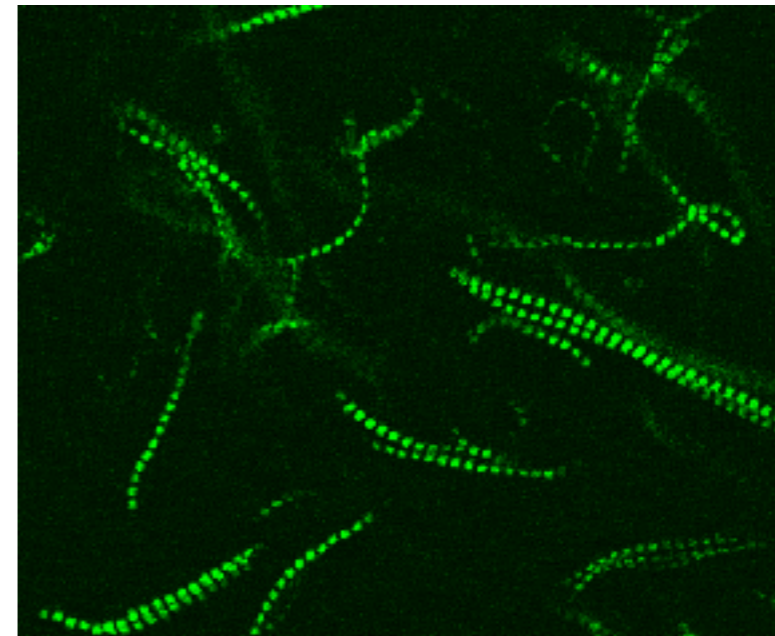

Unlabeled myofibrils.
2P microscopic image

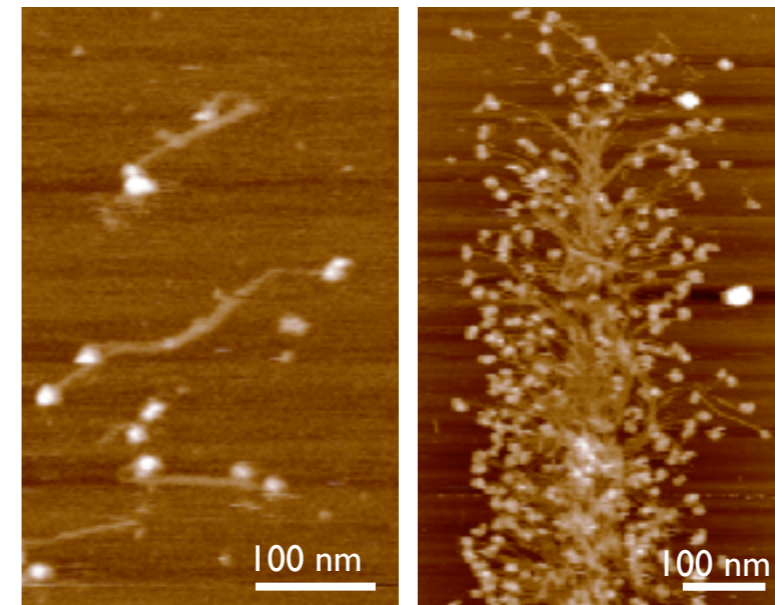

Myosin
molecules
and thick
filament.
AFM image

Dyneins

Types: axonemal and cytoplasmic. Numerous subunits ($M_r \sim 500$ kDa). Move towards the MT minus end. Their coordinated action bends the cilium.

Structure

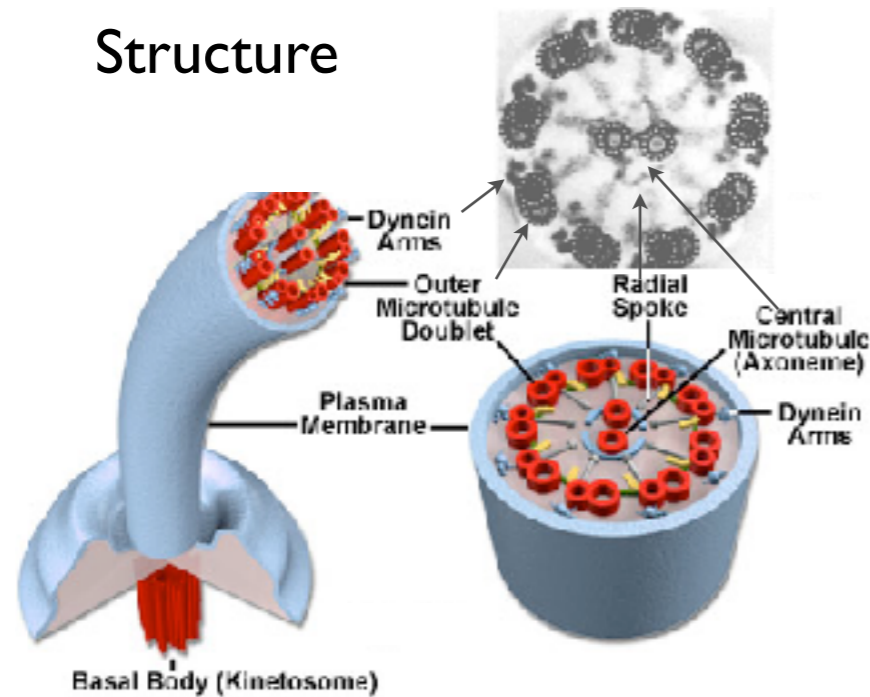

Biomolecular *functional model*:
“*In vitro motility assay*”

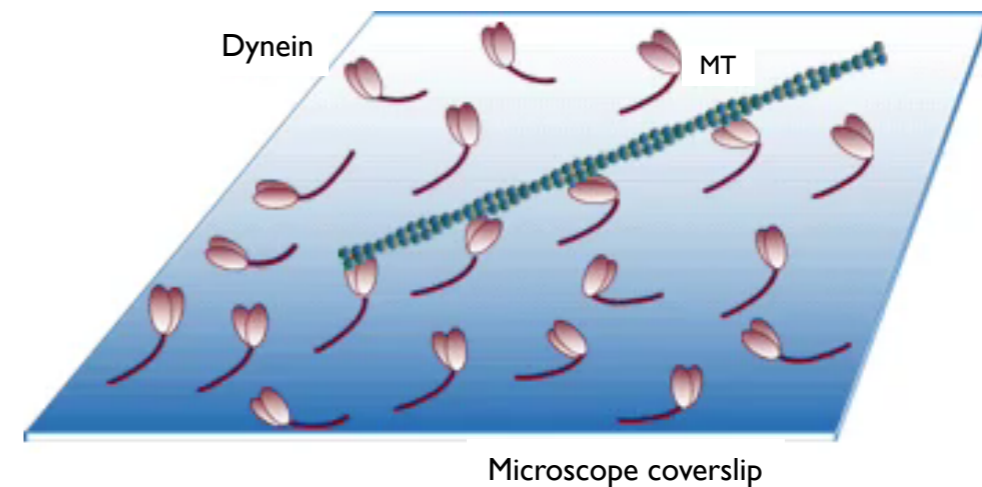

Fluorescence video microscopy

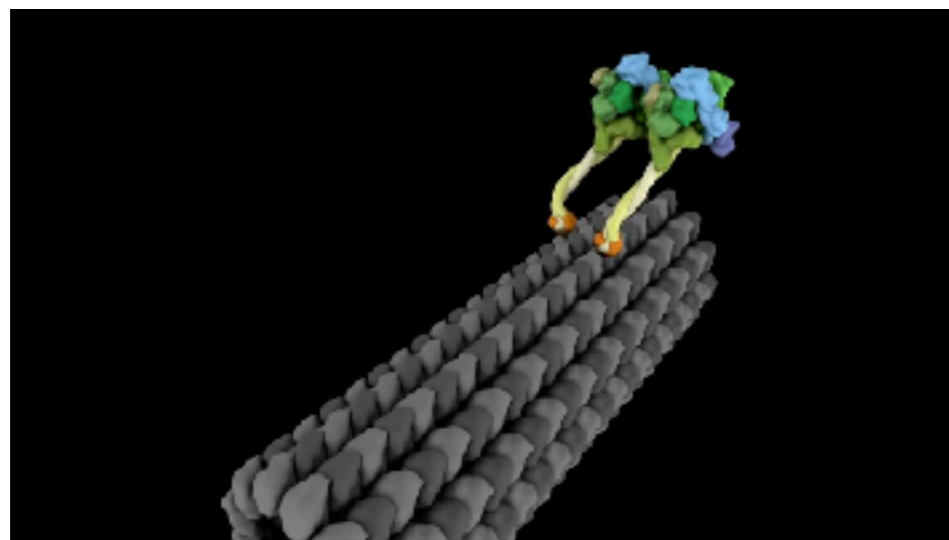

“Drunken sailor” stepping mechanism

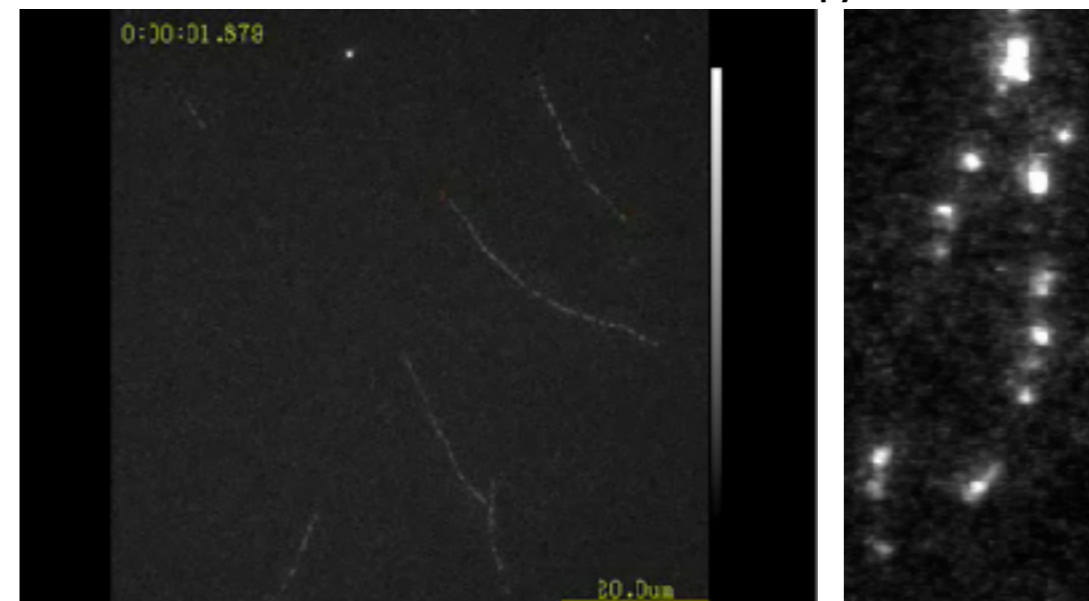

Microtubule moves on dynein

Dynein moves on microtubule

Kinesin superfamily

Processive motors, move mostly towards the plus end of MT

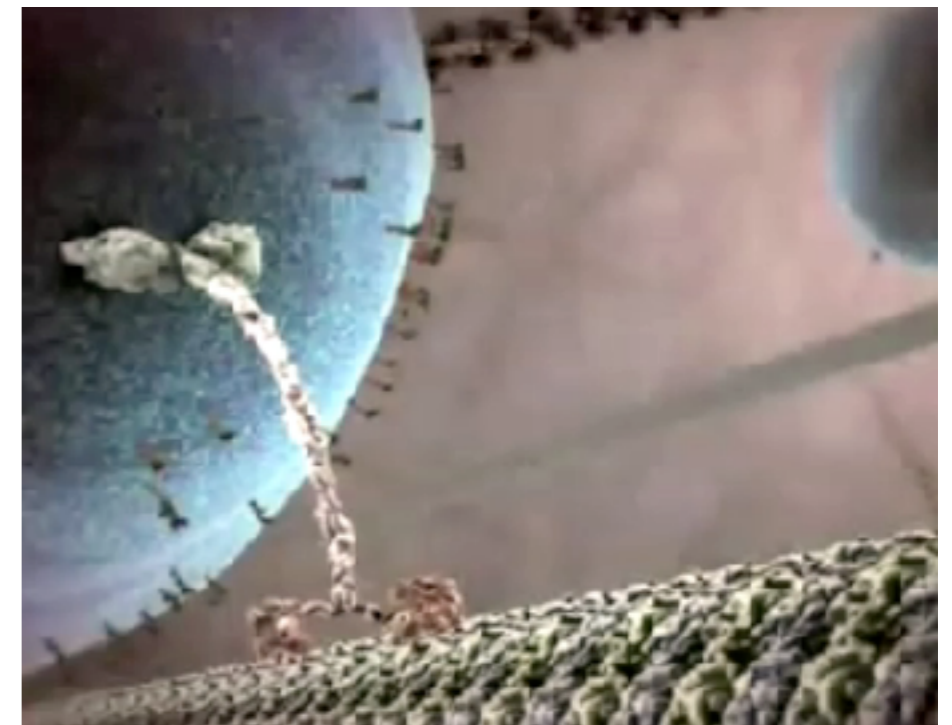
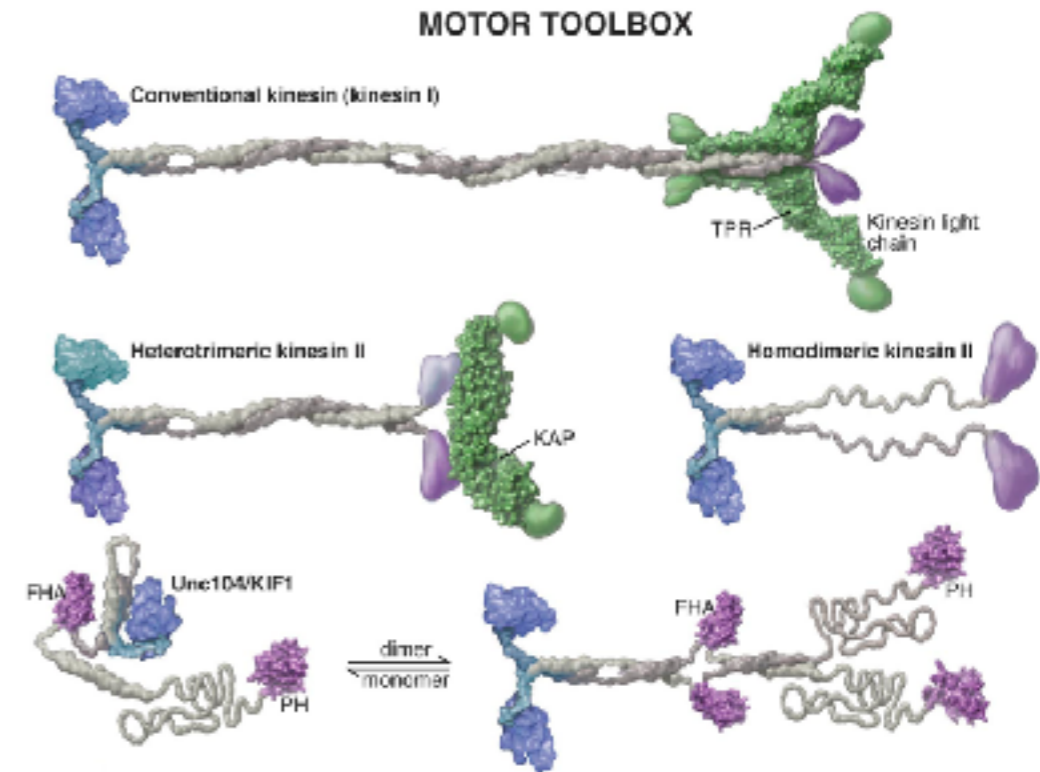
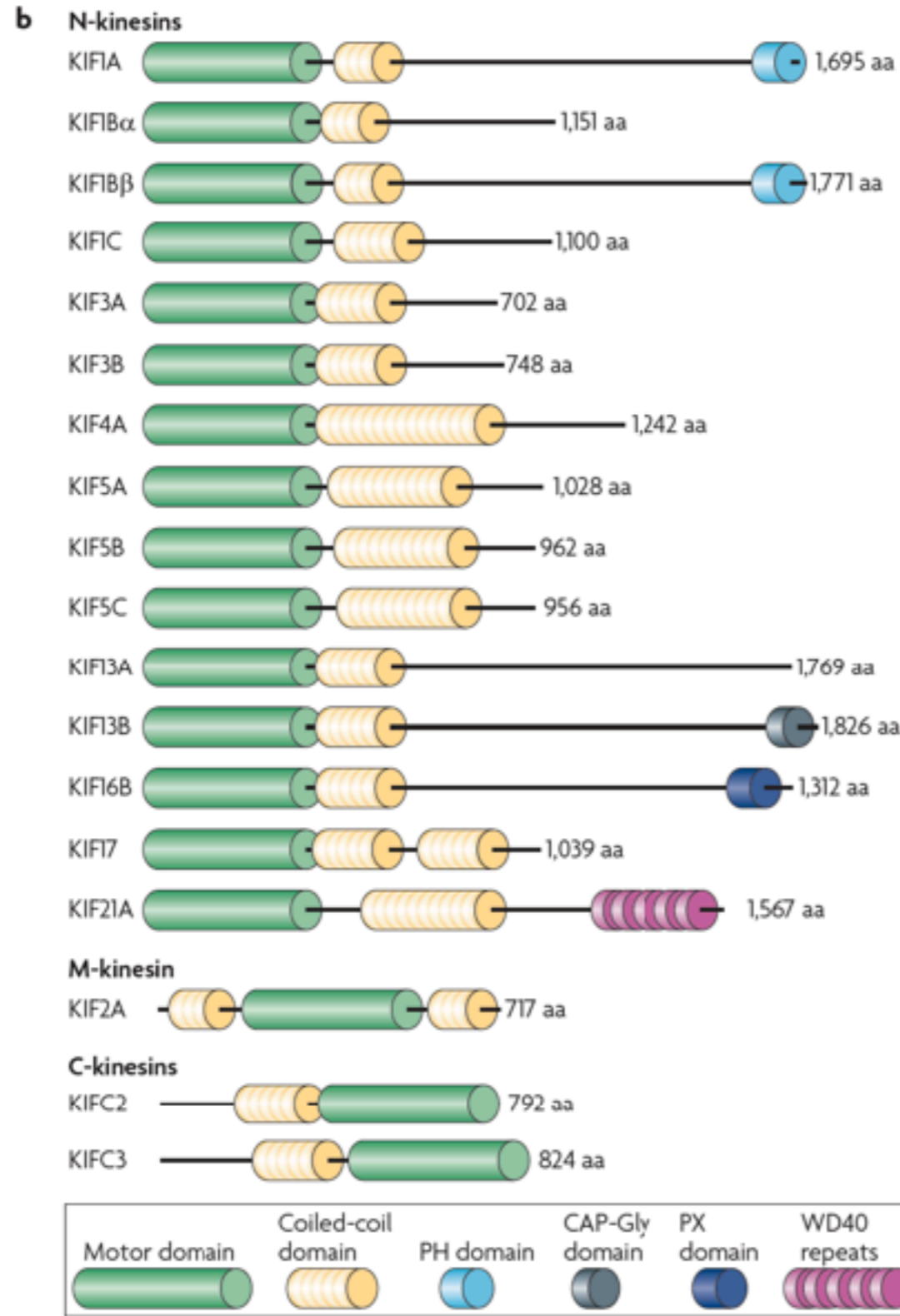
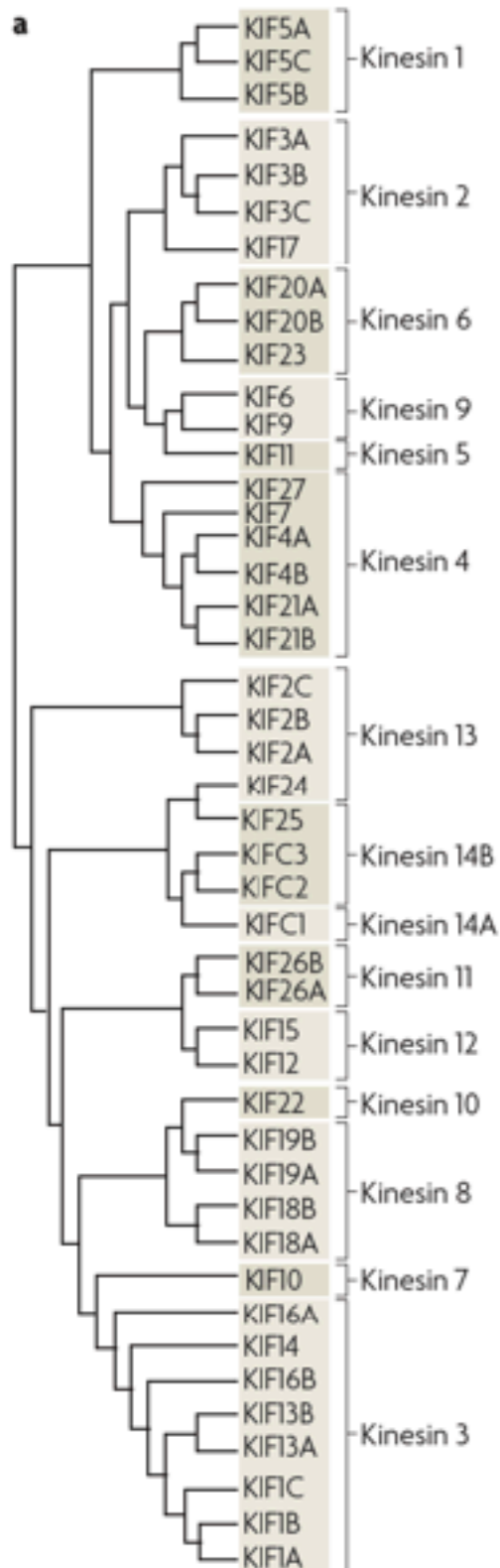

Dynamins

- GTPases
- Important in vacuolar protein sorting

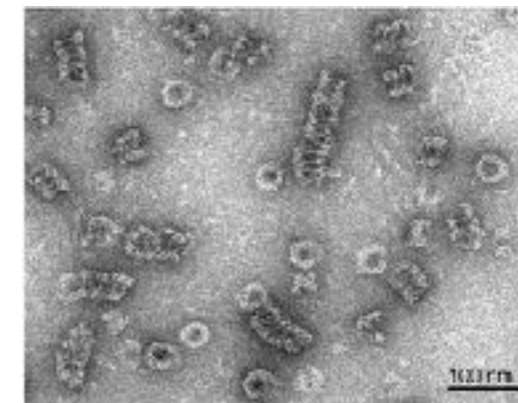
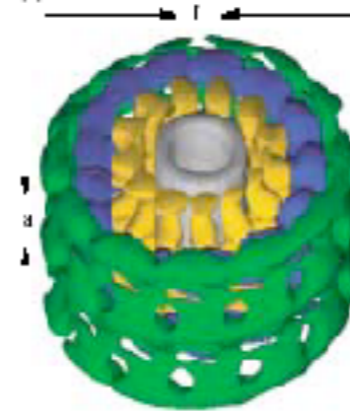
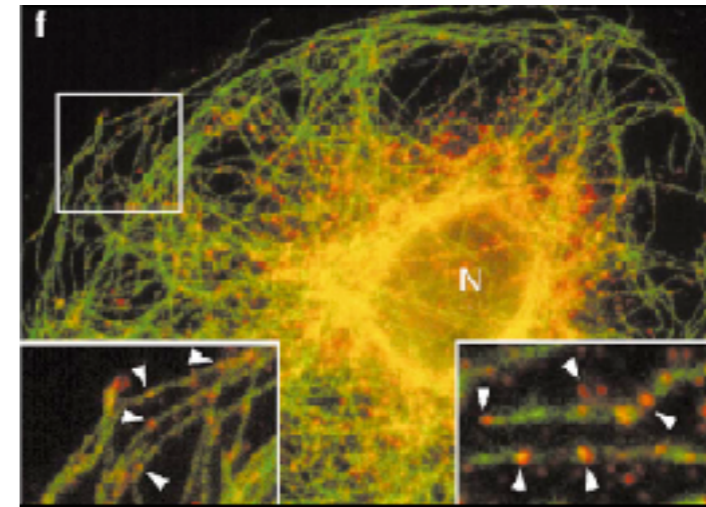
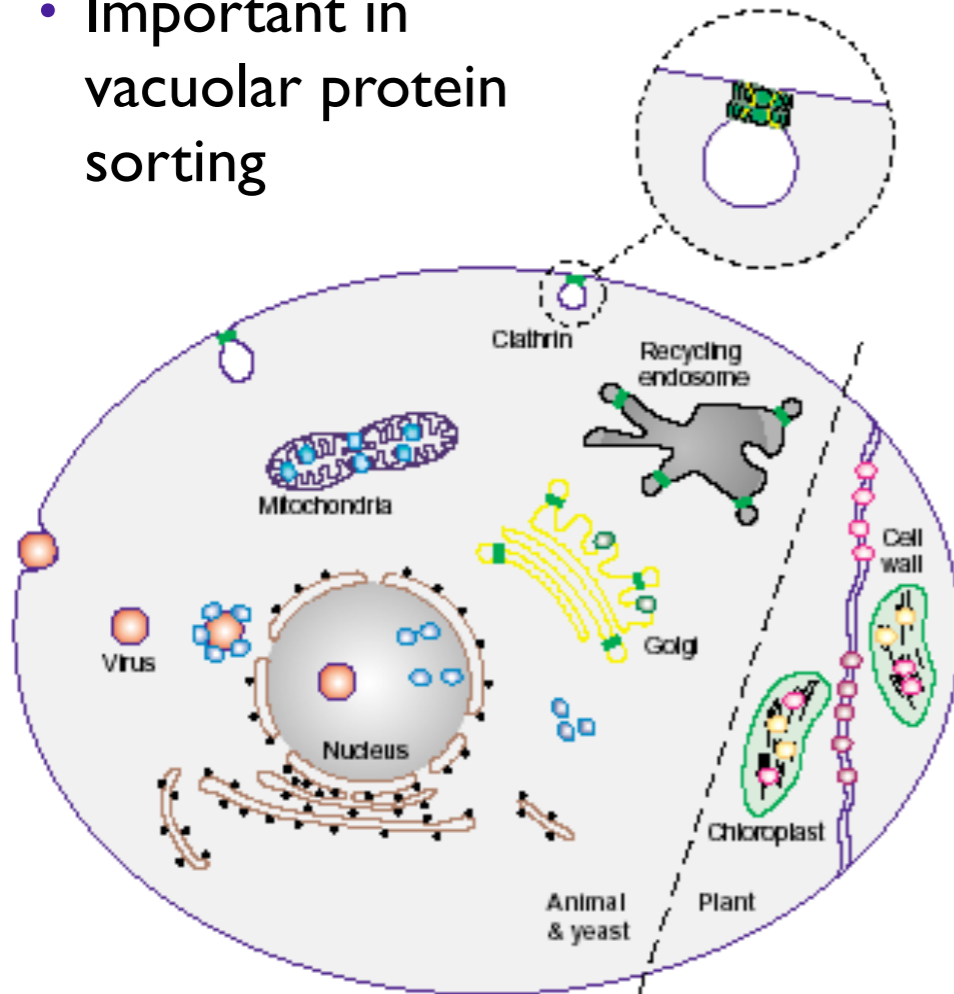

Protein	Localization	Function	Self-assembly
Dynamin	Plasma membrane (clathrin coated, caveolae), Golgi, endosomes	Vesicle formation, fission	+
Vps1	Golgi	Vesicle formation and transport	Unknown
Dnm1/Drp1/DRP-1	Mitochondria outer membrane	Mitochondrial fission & morphology	+
Mgm1/Msp1/OPA1	Mitochondria inner or outer membrane, or matrix	Mitochondrial morphology	Unknown
Phragmoplastin	Cell wall	Membrane morphology	+
ADL1	Cell wall, chloroplast	Membrane biogenesis	+
ADL2	Chloroplast	Unknown	Unknown
hGBP1	Cytoplasm	Anti-viral activity	+
Mx	Cytoplasm, nucleus	Anti-viral activity	+



“pinchase” function

Viral portal motor

Unique DNA motor

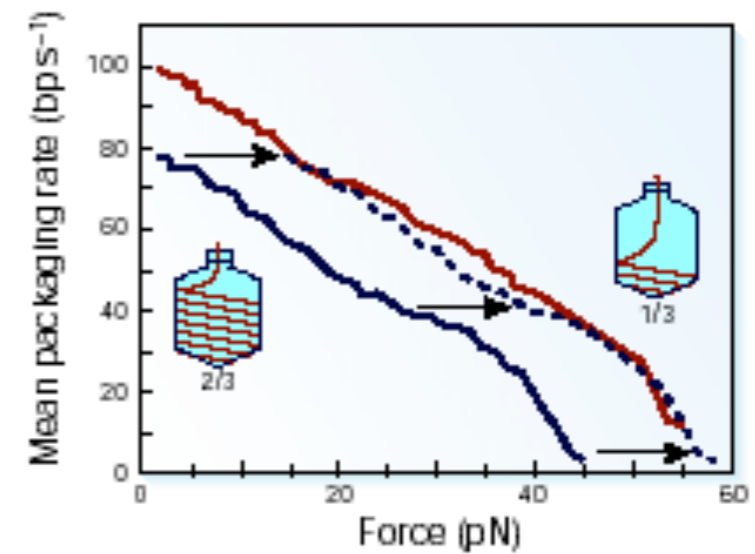
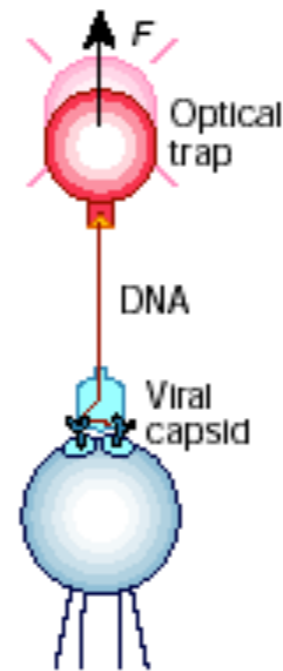
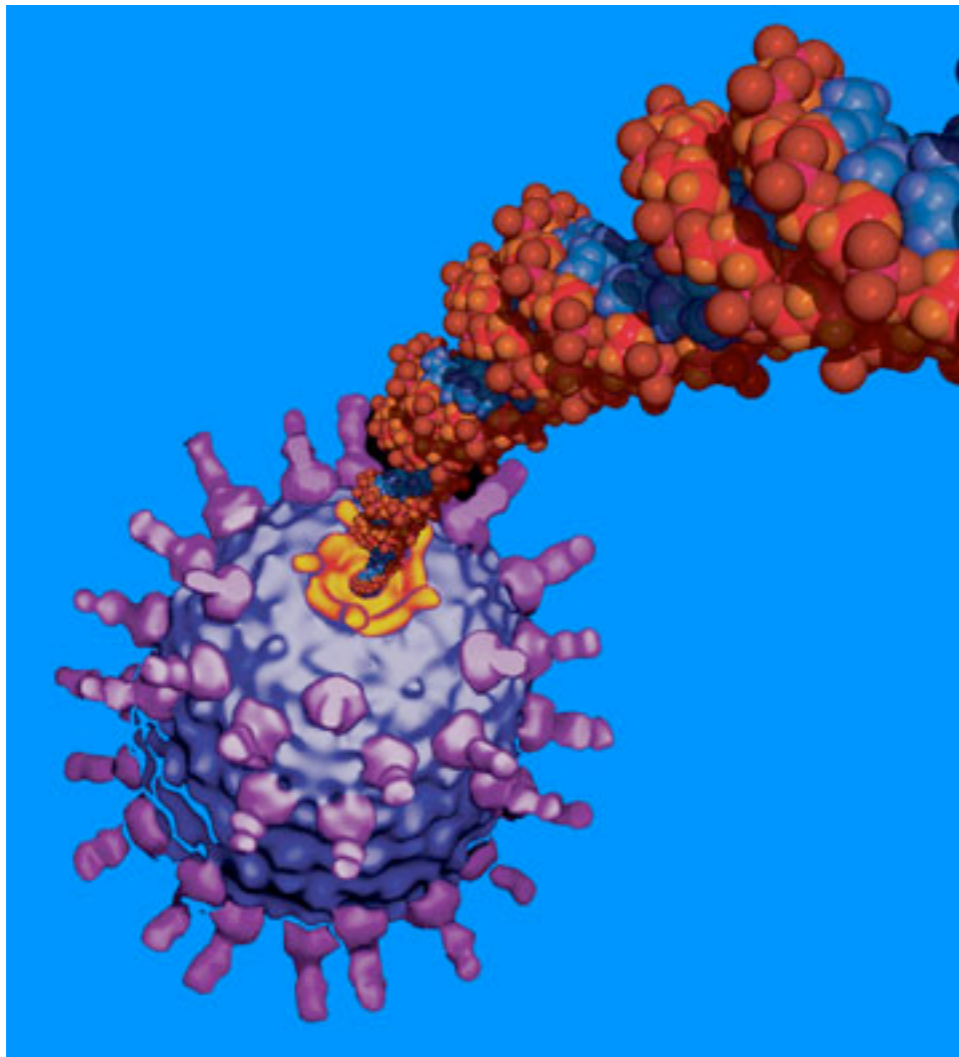

$\phi 29$ bacteriophage portal motor

Viral capsid mechanical rupture - irreversible process

T7 phage

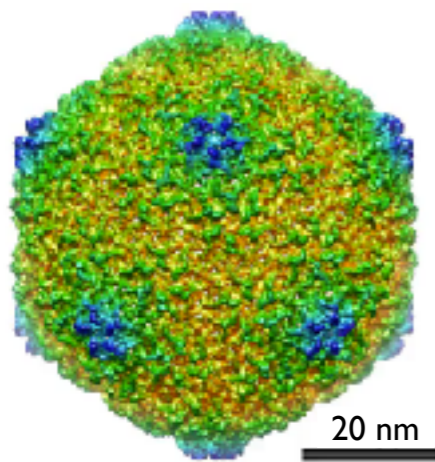

20 nm

lonel et al. *J.Biol.Chem.* 286, 234, 2010.

AFM

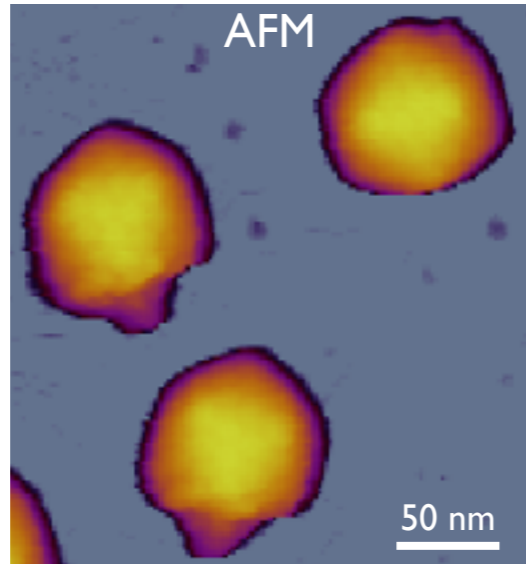

50 nm

AFM tip



T7 kapszid



Trepanated inca skull,
Museo Rafael Larco Herrera, Lima

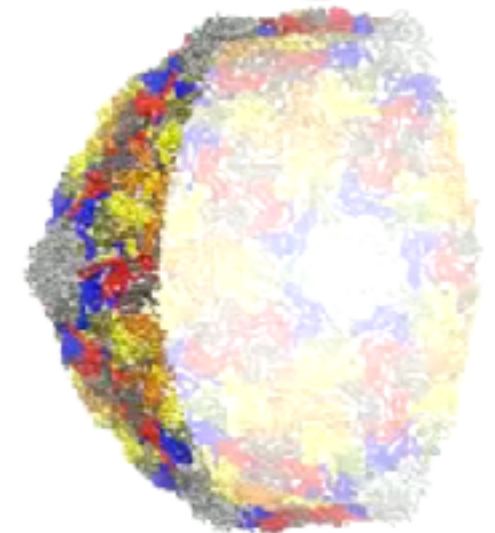
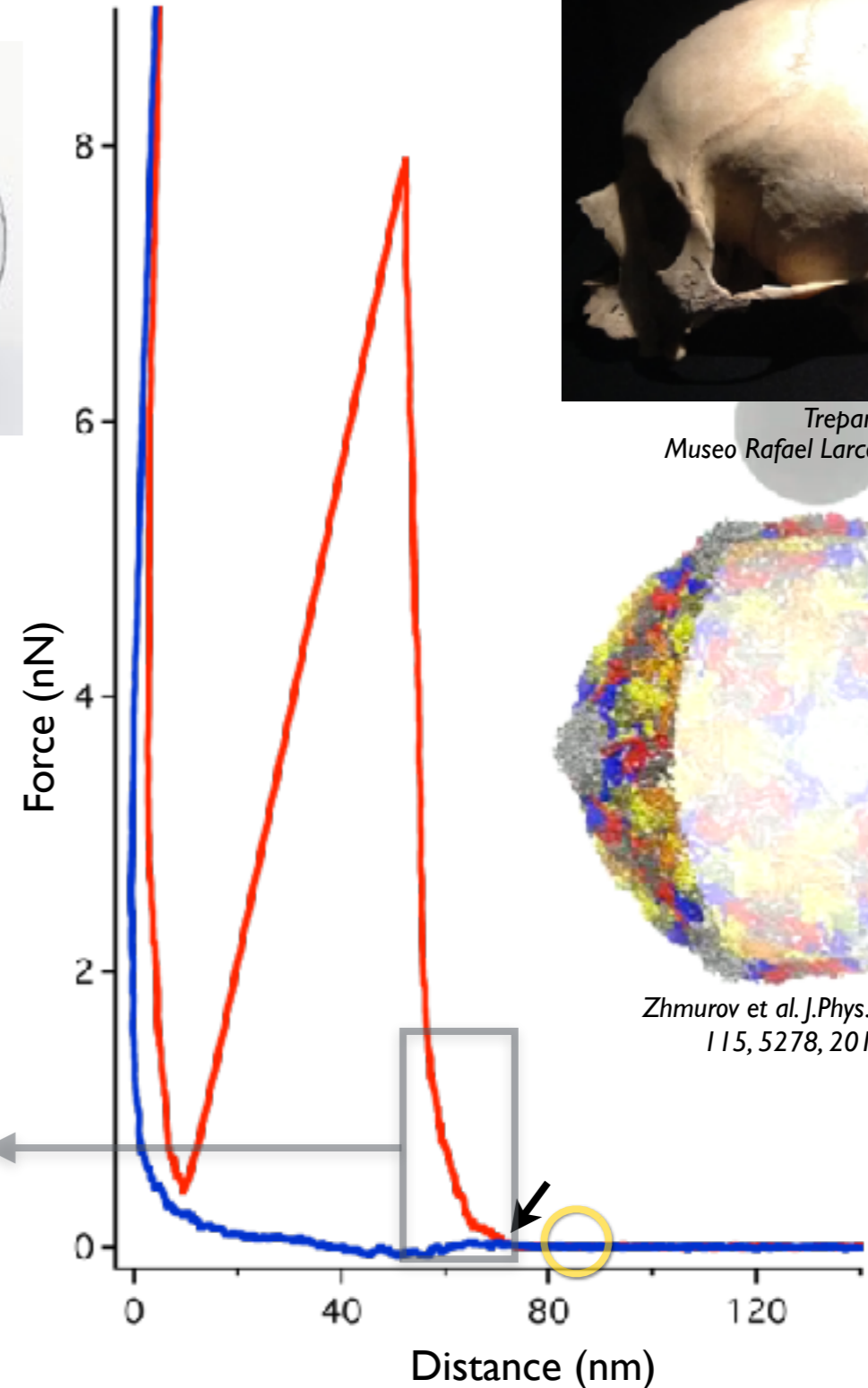
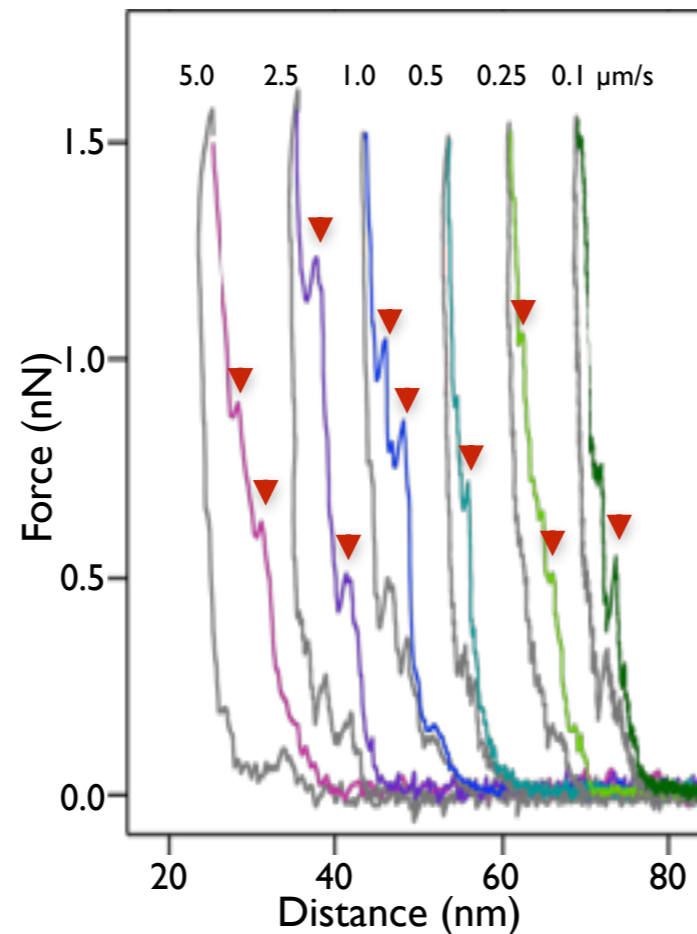
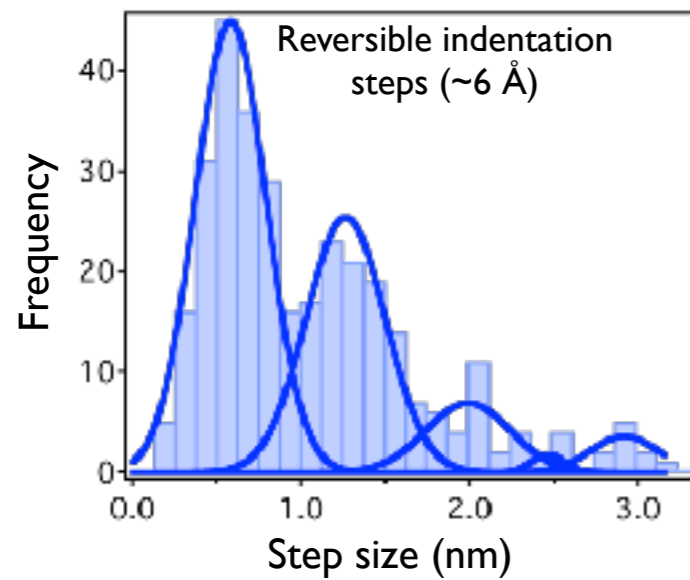

Zhmurov et al. *J.Phys.Chem.B* 115, 5278, 2011.

SARS-CoV-2 is highly resilient

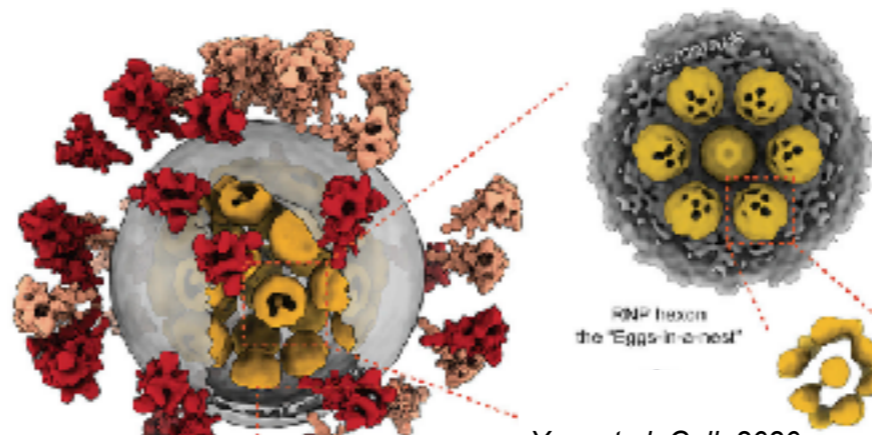
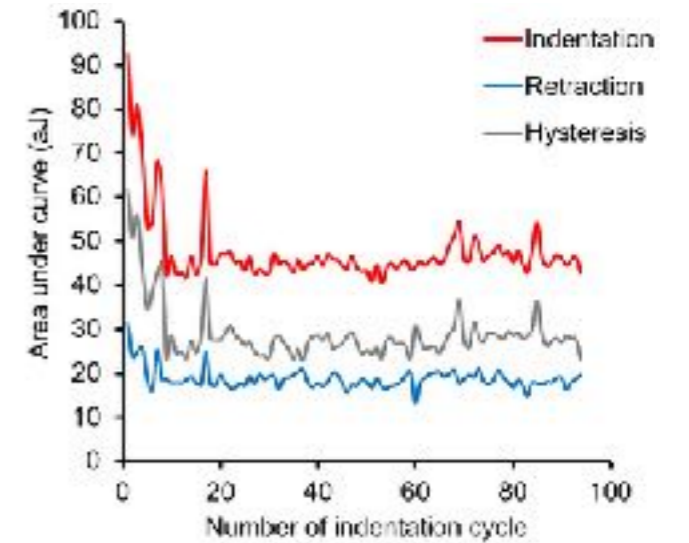
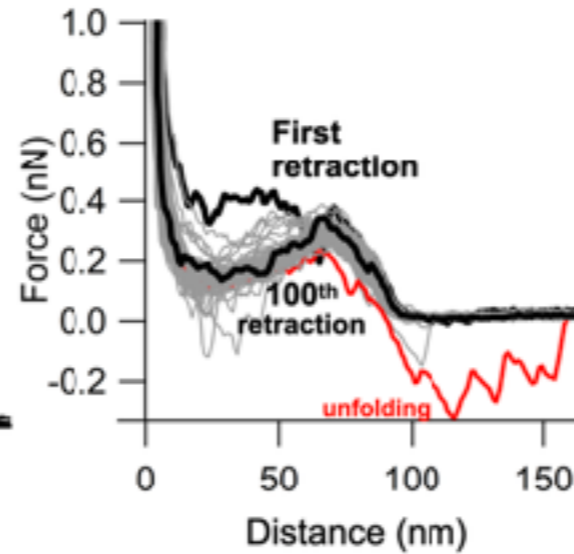
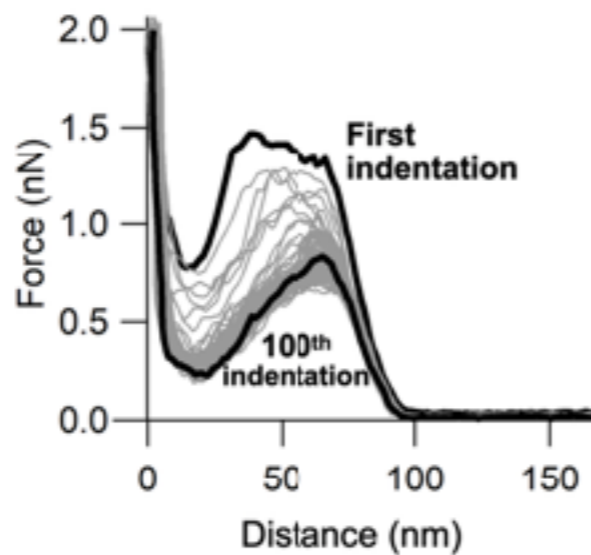
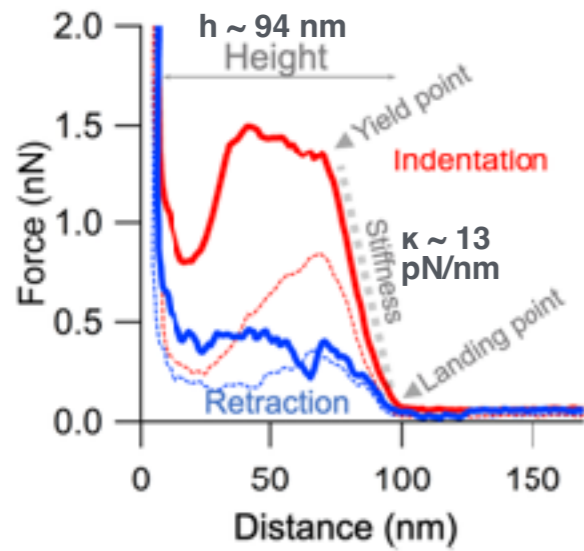
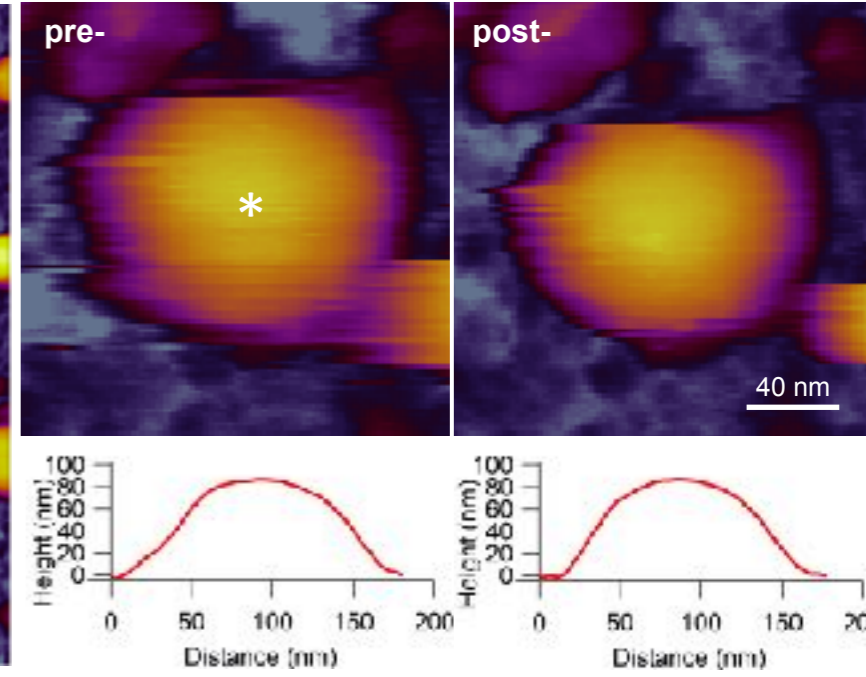
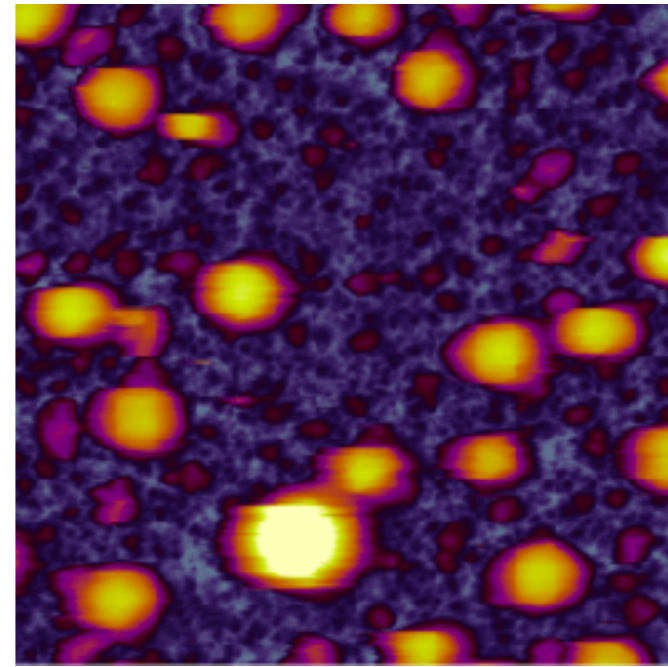
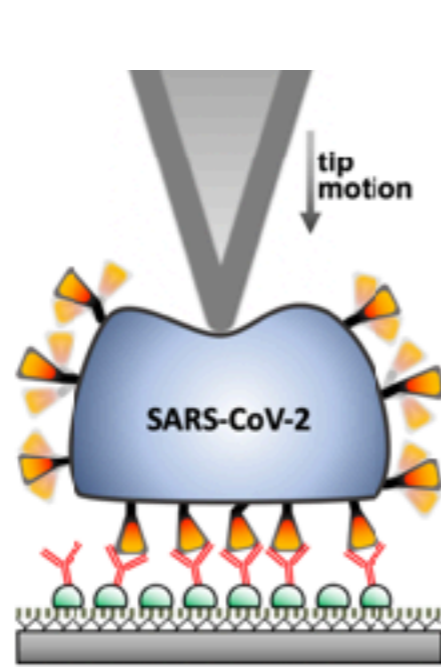
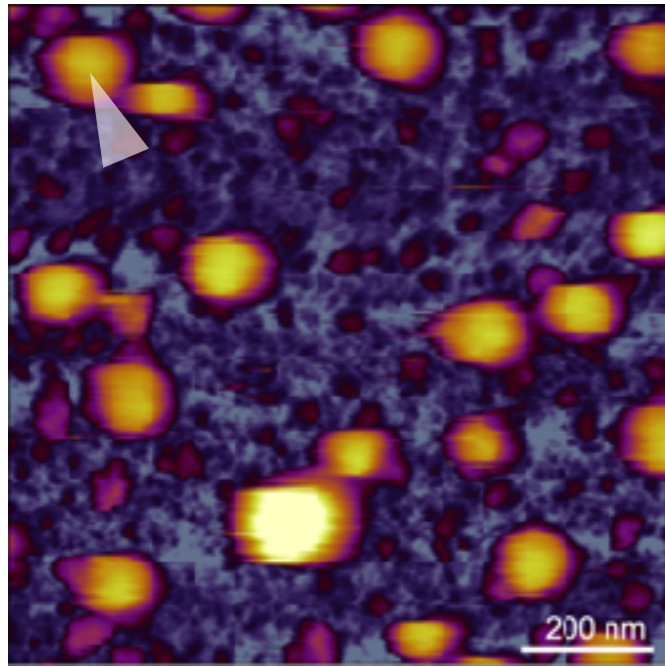

Nest-like organization of RNP in SARS-CoV-2 may yield to nanoindentation

Video by Scixel

Yao, et al. Cell, 2020

Kiss et al. Nano Lett 2021

Force-induced DNA ejection from T7 phage

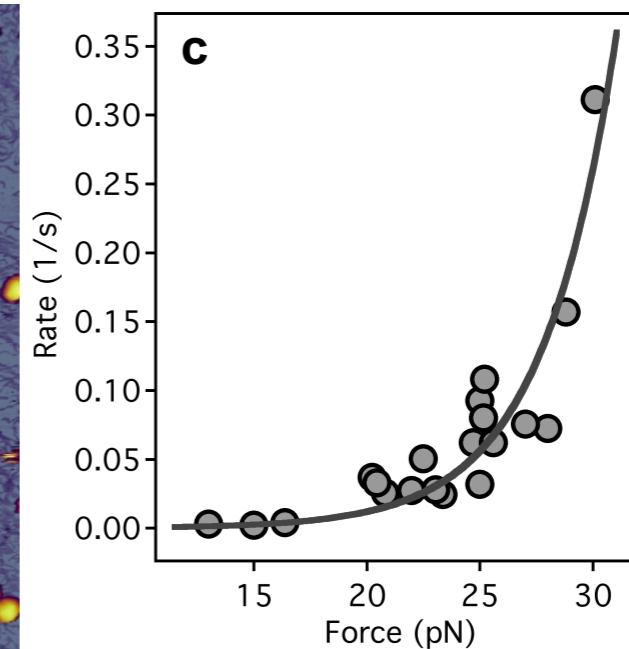
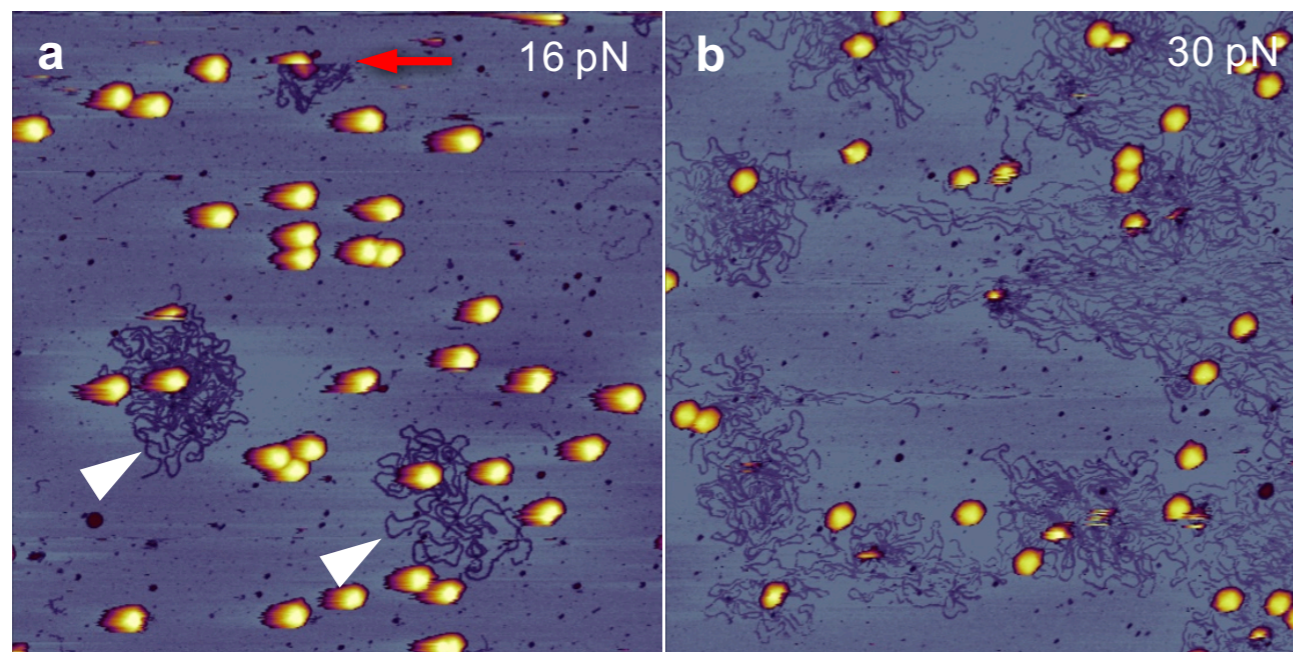
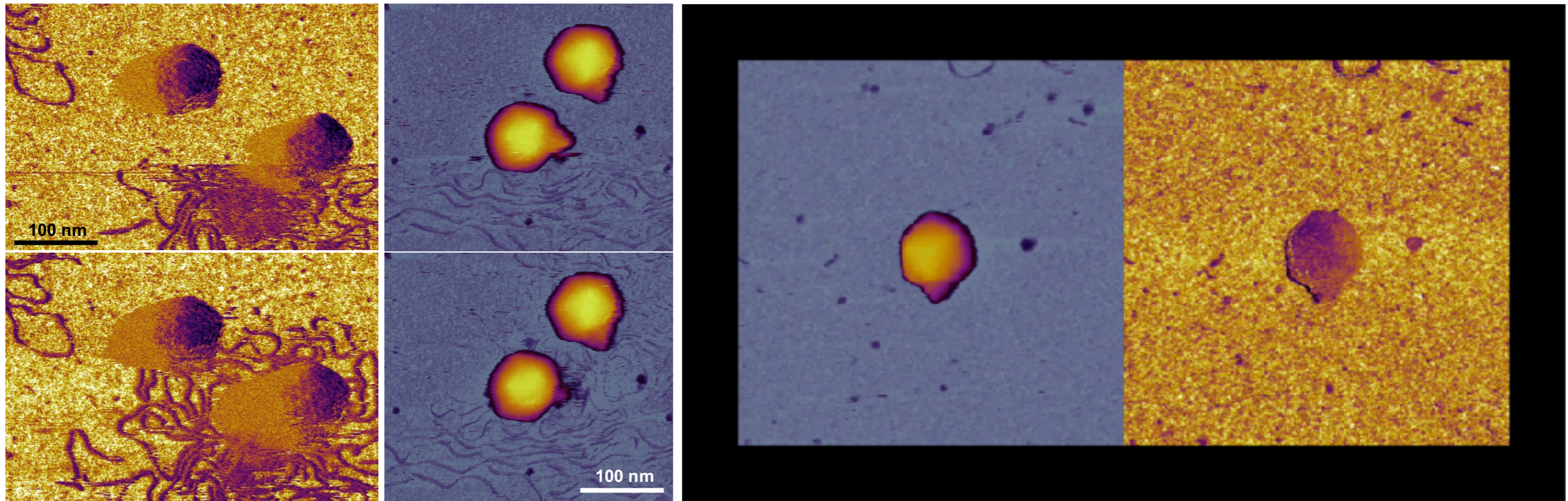

T7 DNA release may be under mechanical control

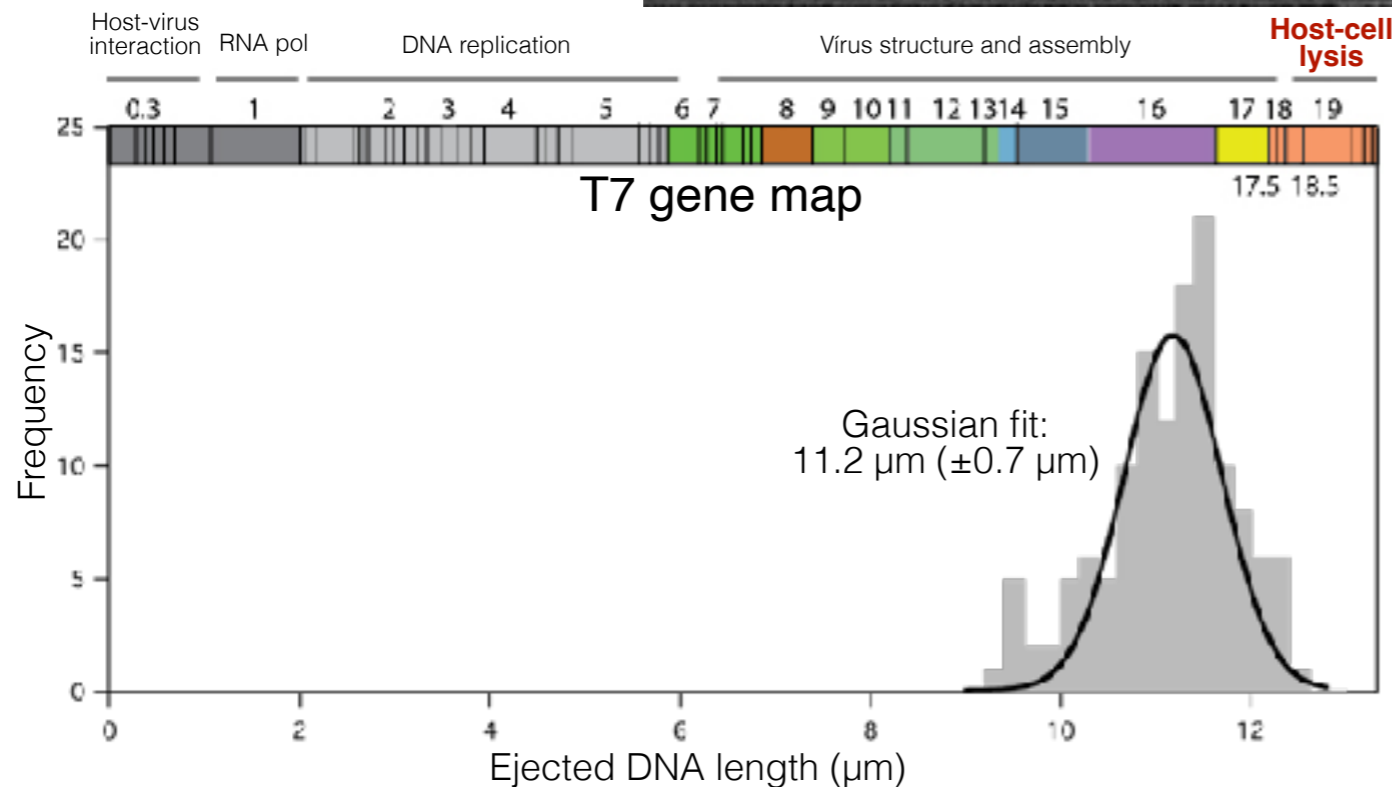
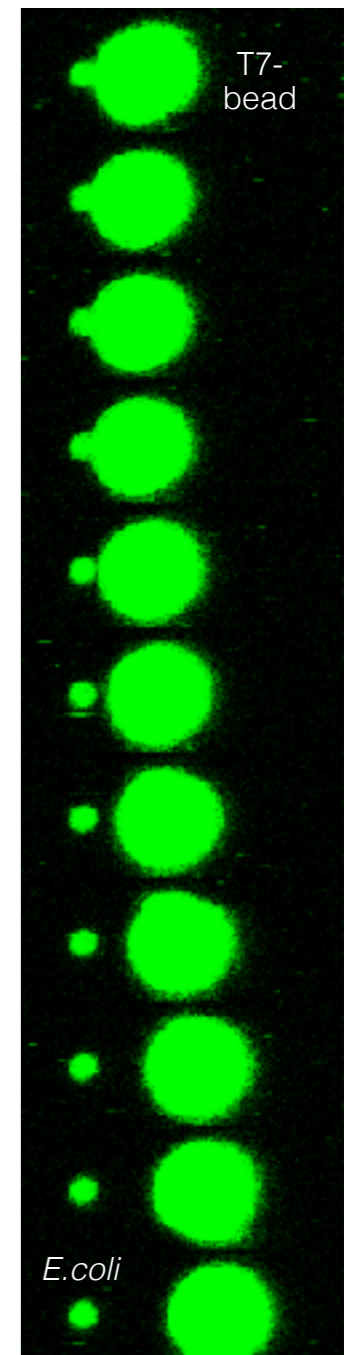
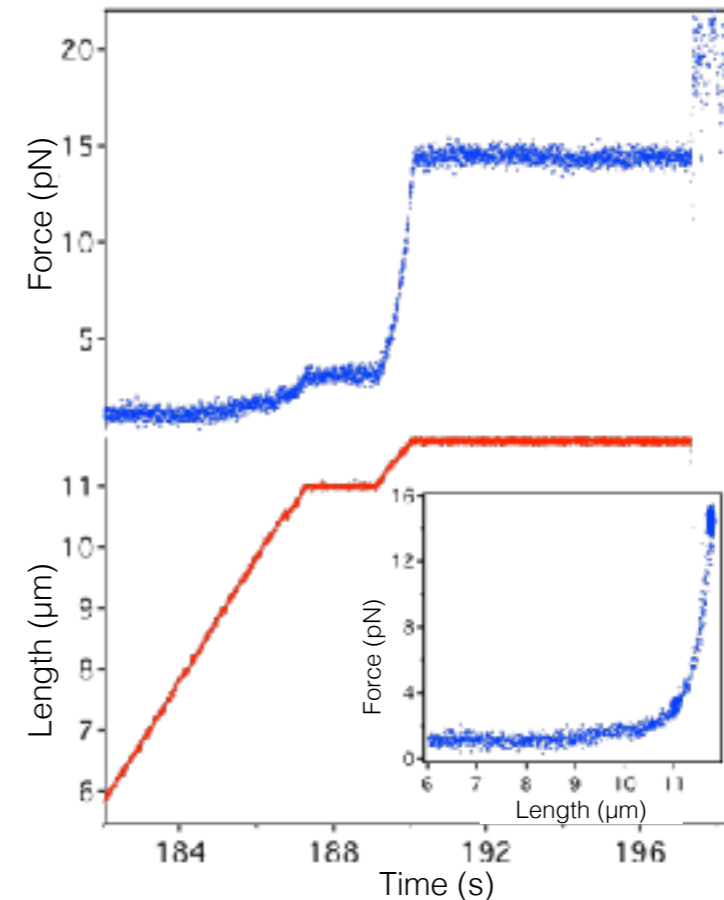
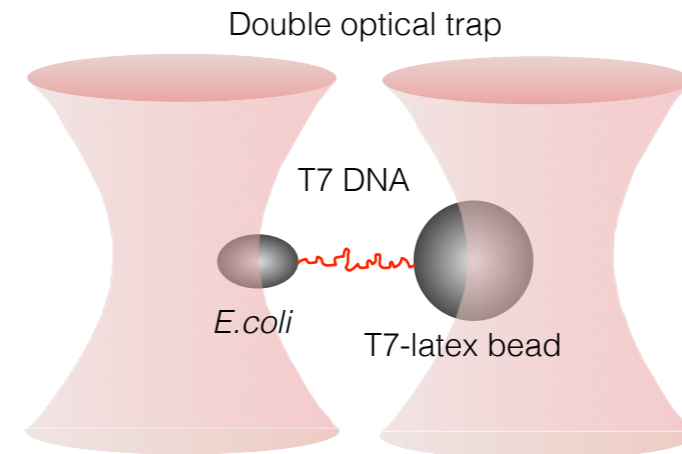
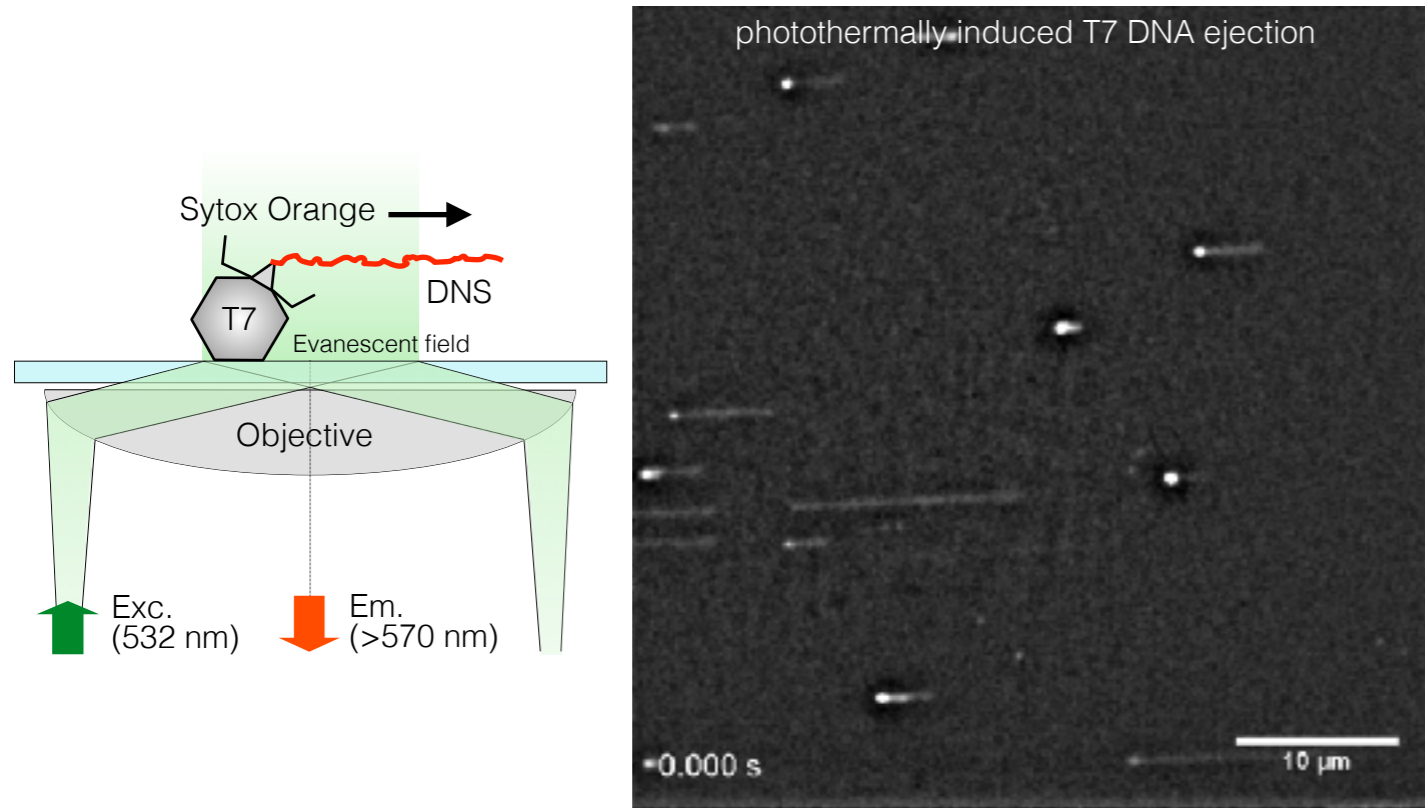

Rotary motors I: F1F0-ATP Synthase

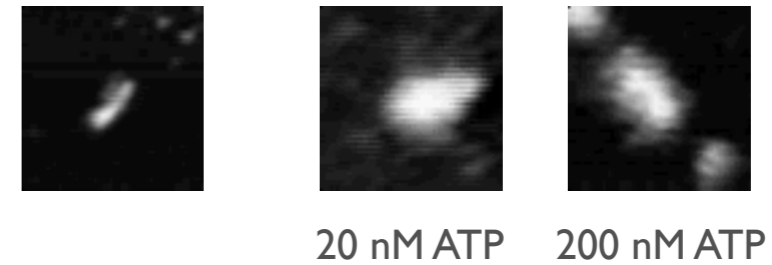
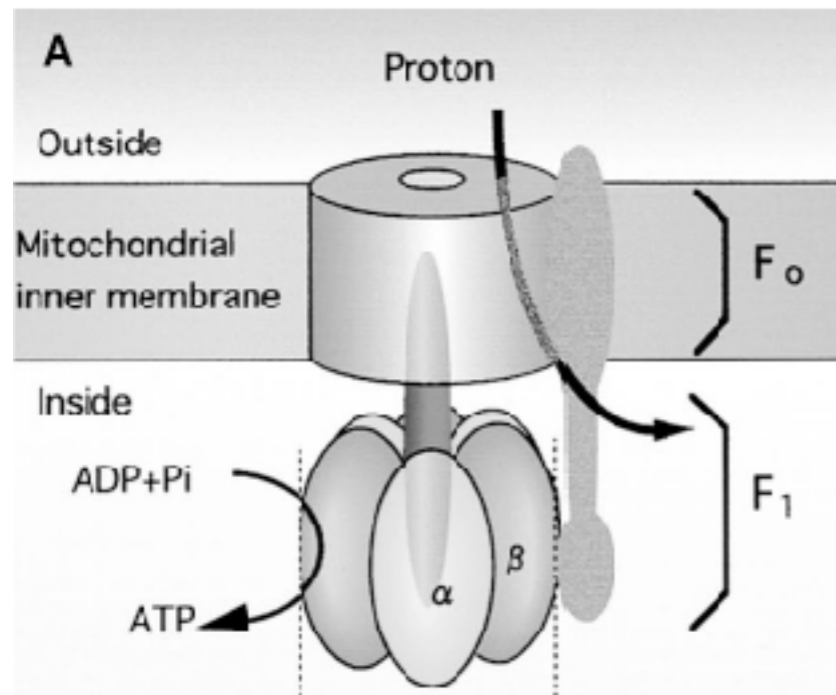

Discrete 120° rotational steps

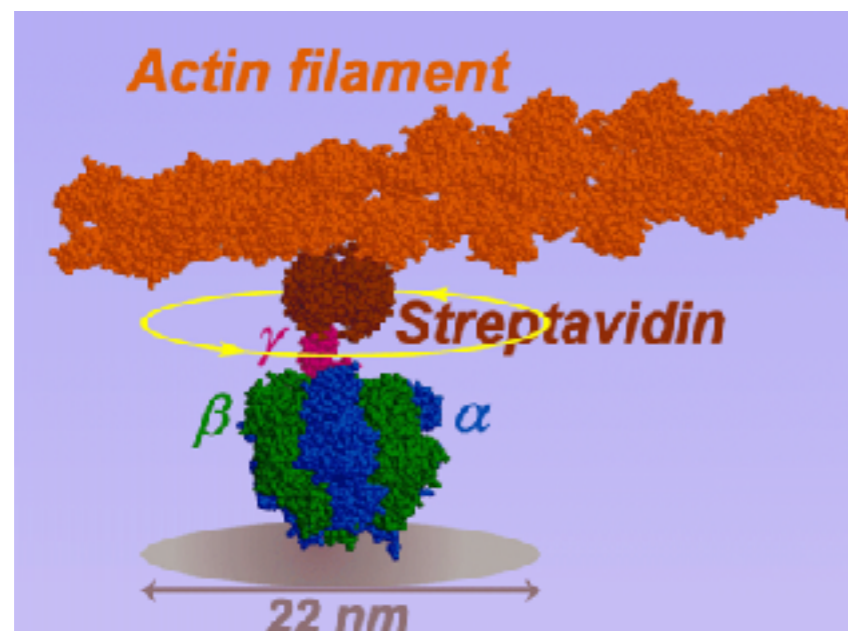
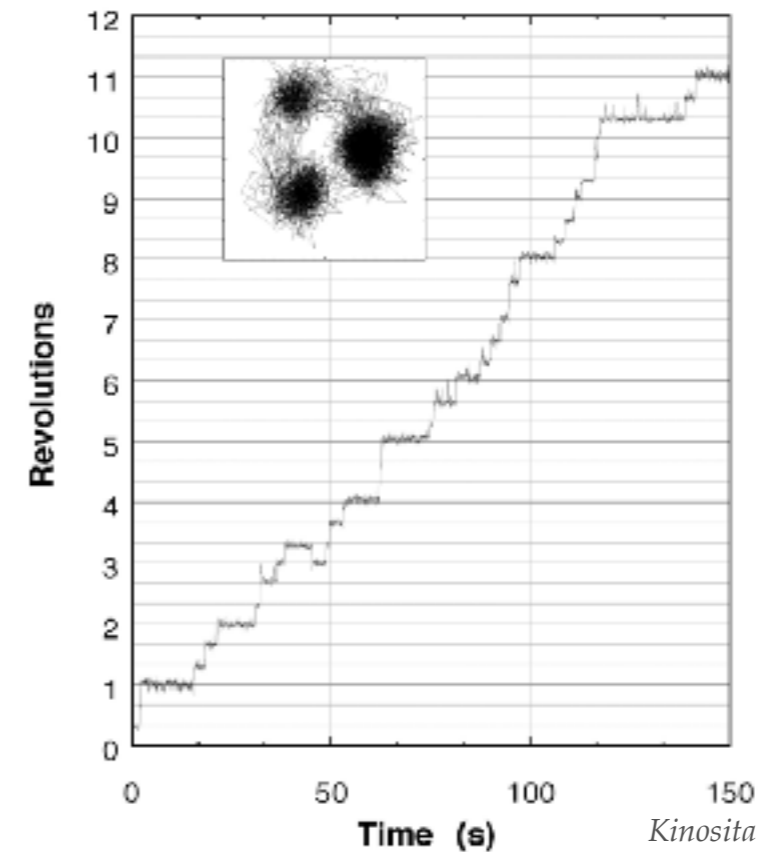

Rotary motors II: Bacterial flagellar motor

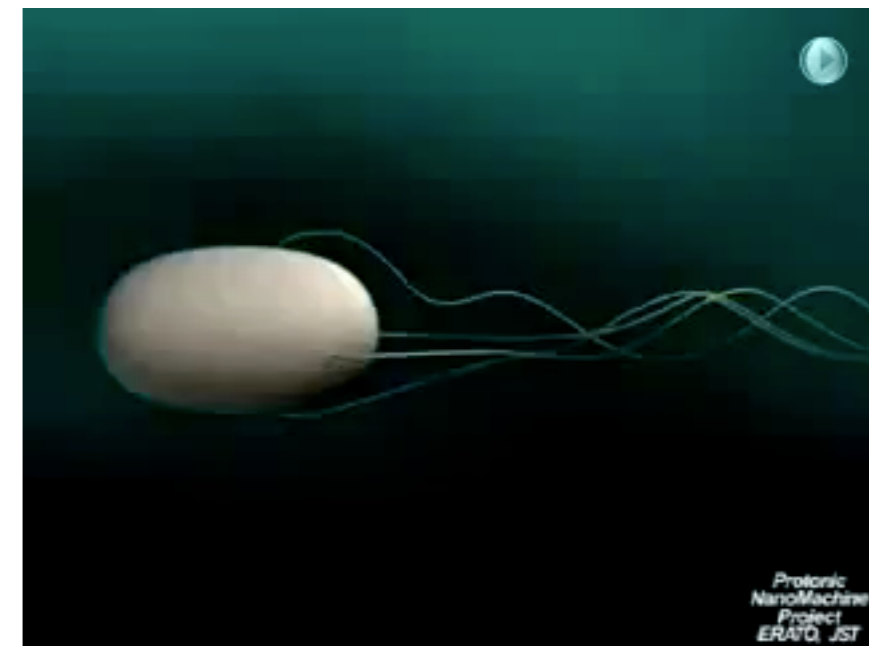
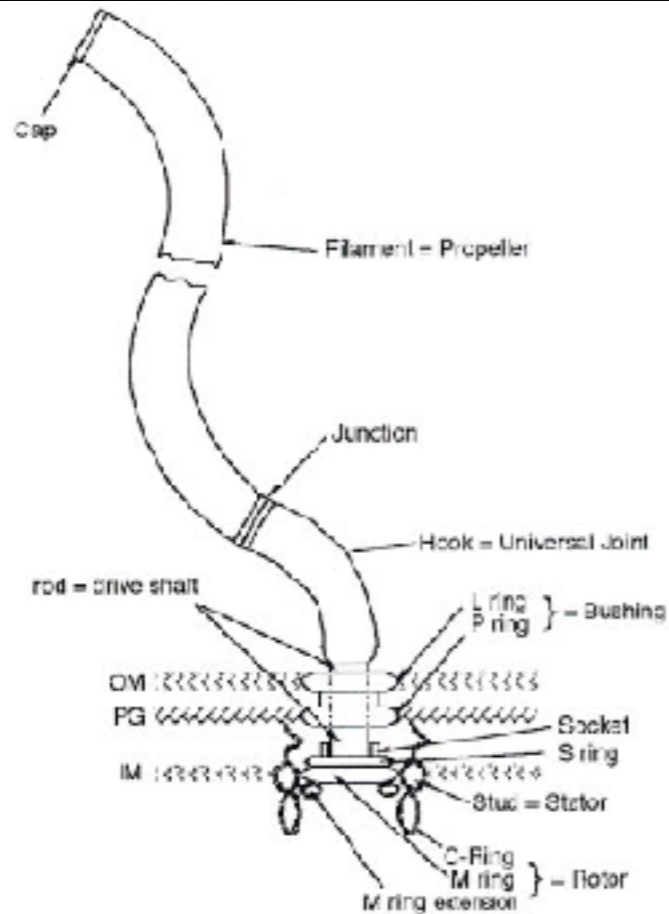
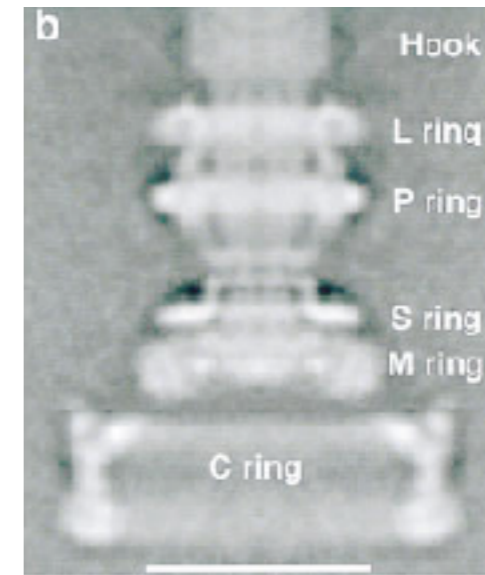

Rotational frequency: > 20000 rpm
Power consumption: 10^{-16} W
Efficiency: > 80%
Energy source: protons

Force-driven protein folding

Nanomanipulation of titin

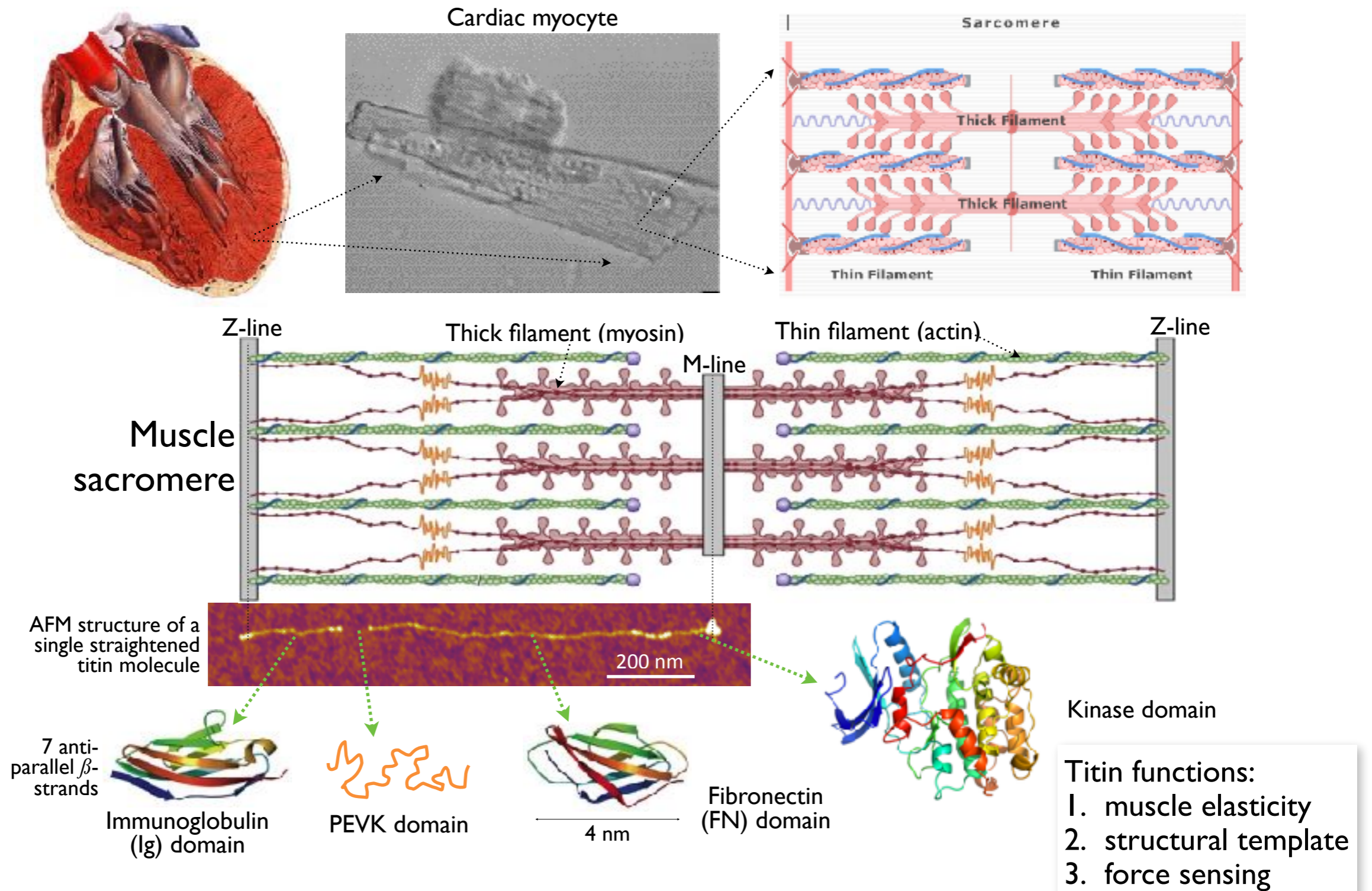

Upon stretching with force, titin unfolds

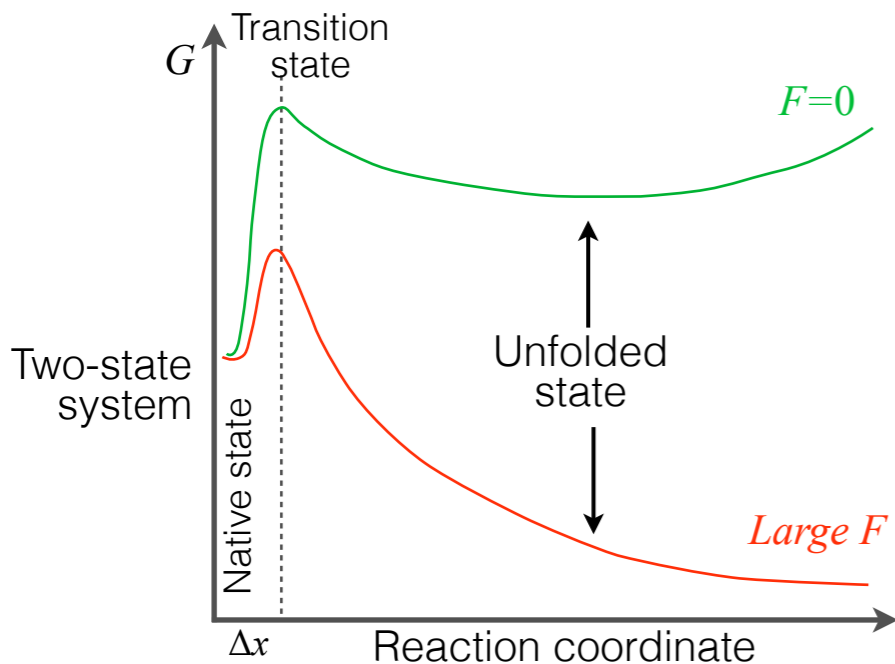
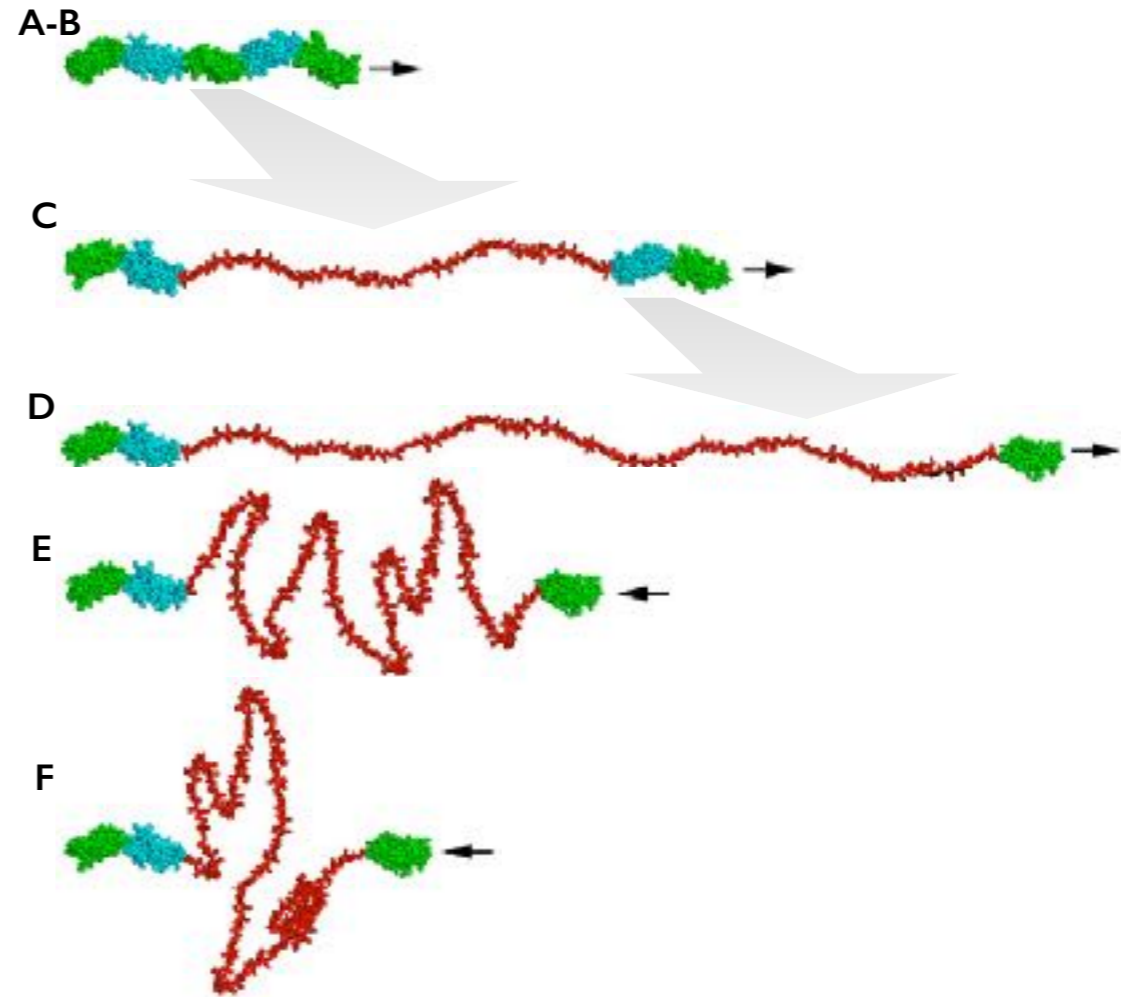
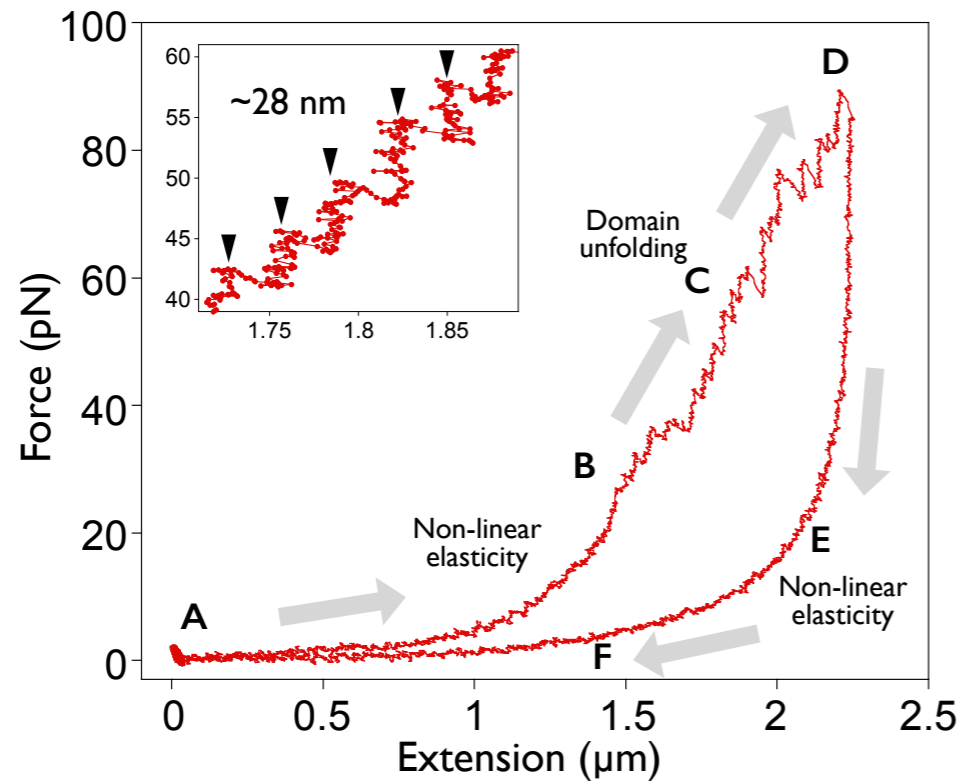

Force-driven domain unfolding rate:

$$k_F = k_0 e^{F\Delta x/k_B T}$$

k_0 : spontaneous unfolding rate

Domain unfolding:

1. all-or-none
2. no intermediates
3. dictated by the hierarchy of mechanical stabilities of domains

How does titin contract?

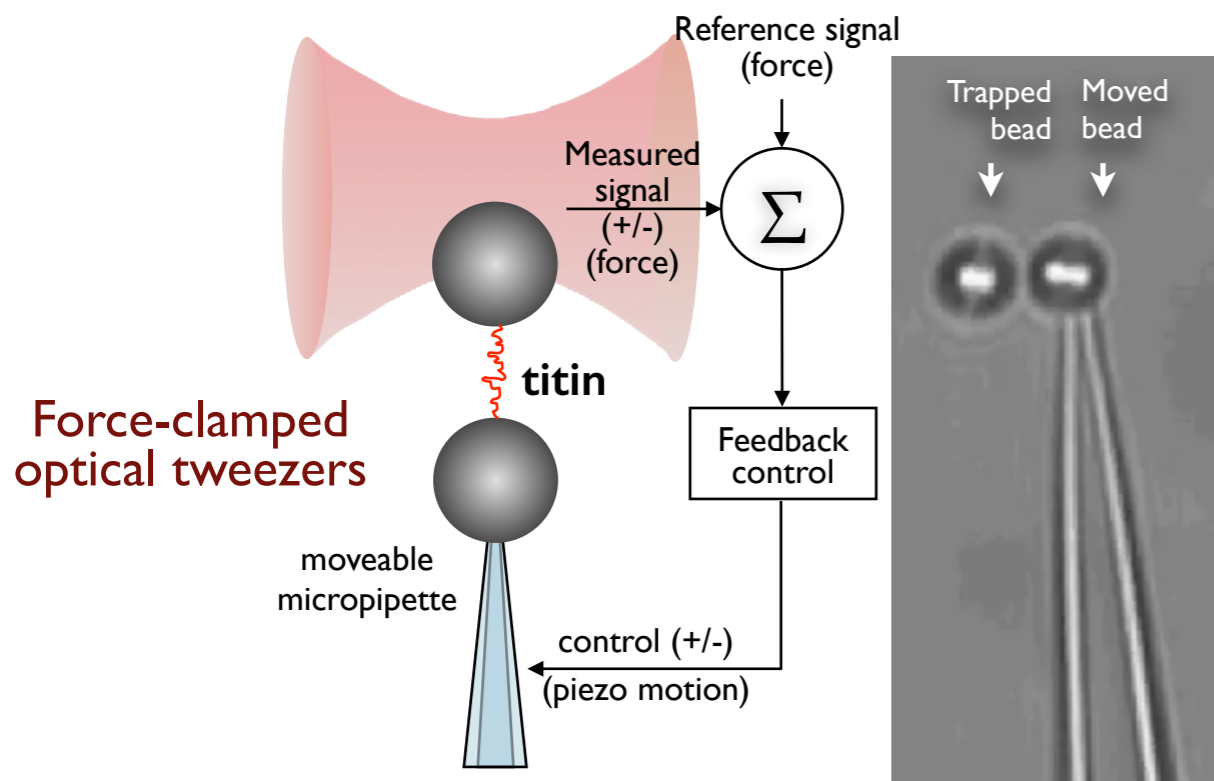
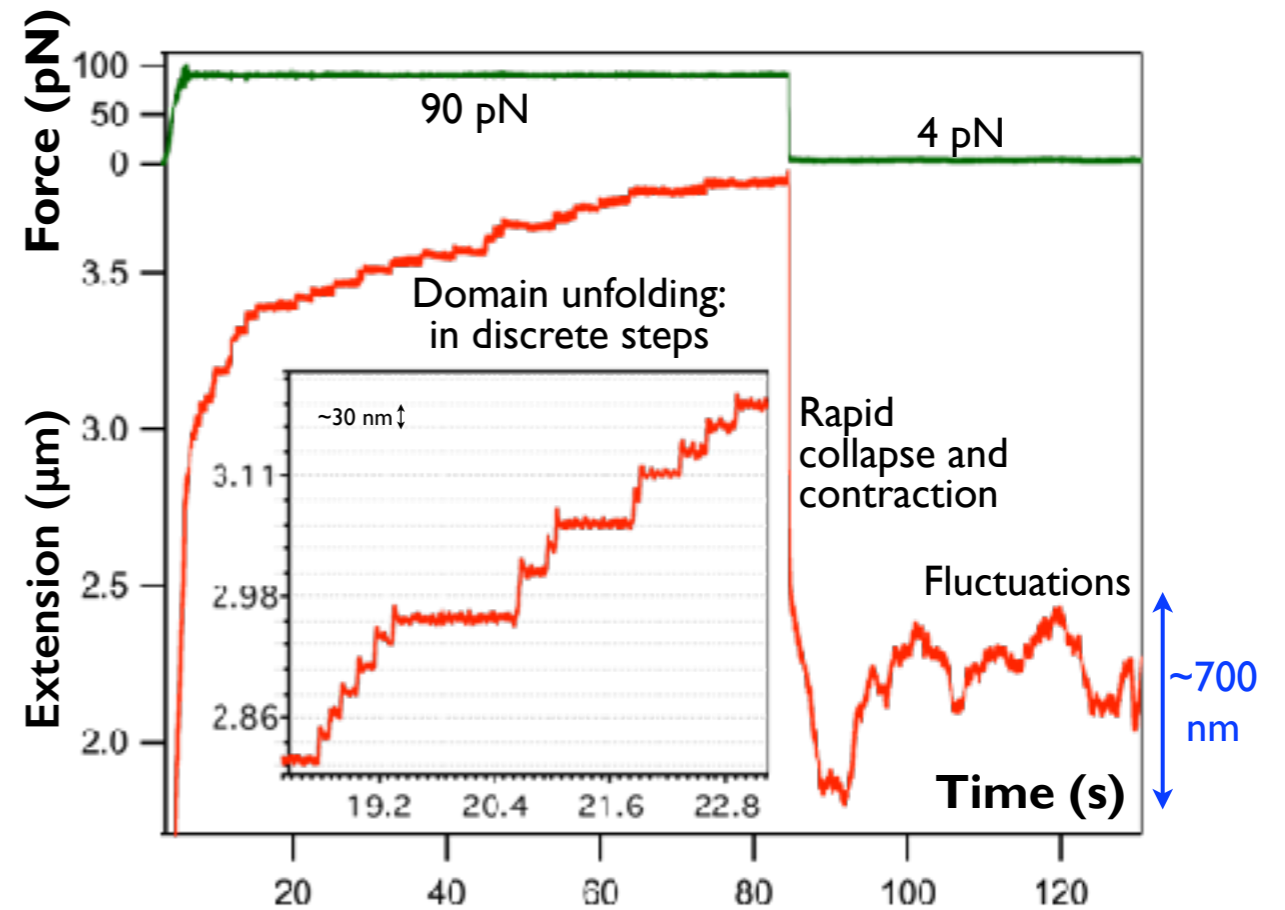
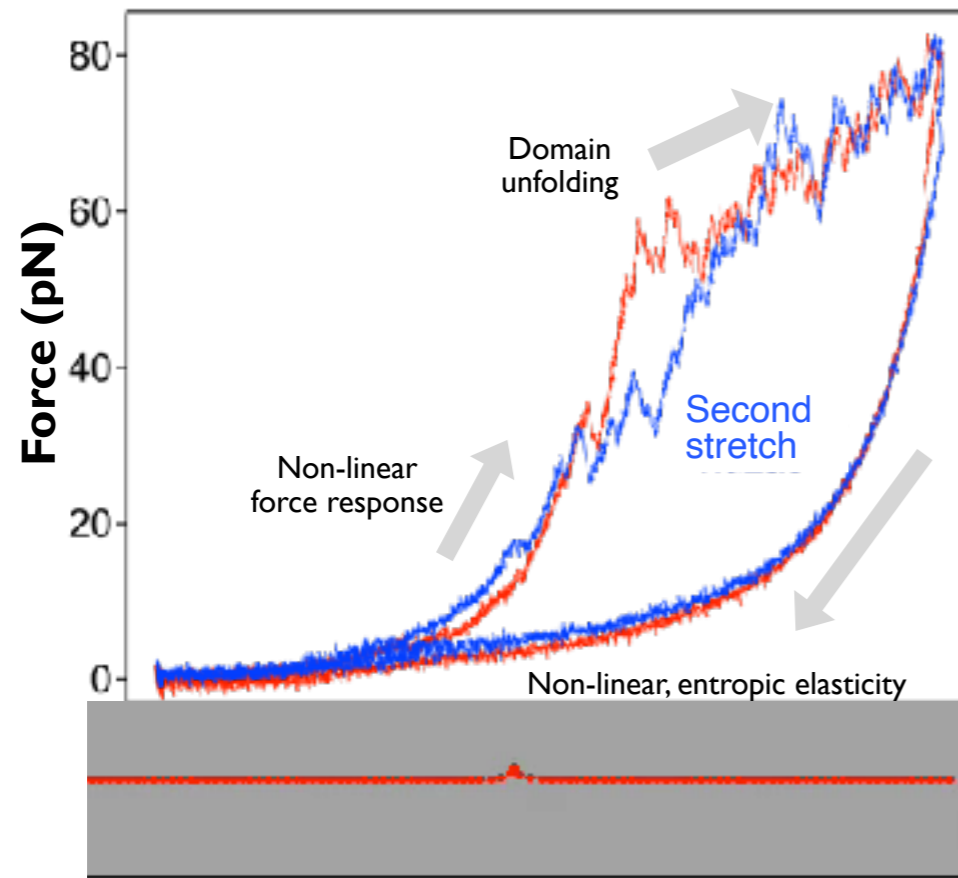

Fluctuations cannot be explained with a two-state system

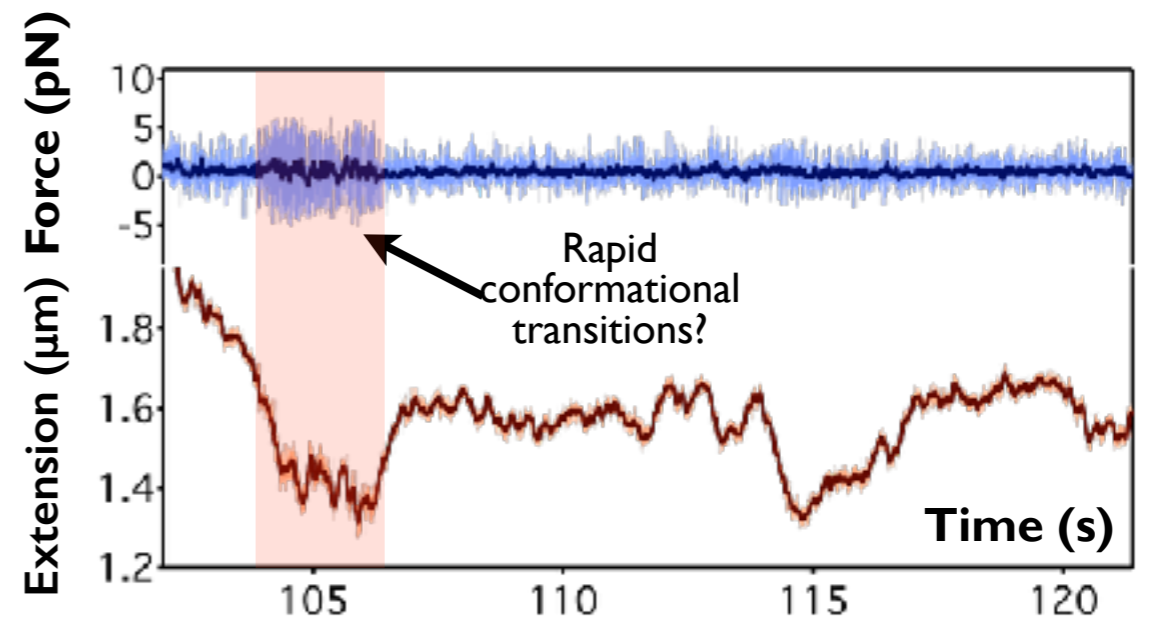

Force is generated during refolding

Position clamp experiment

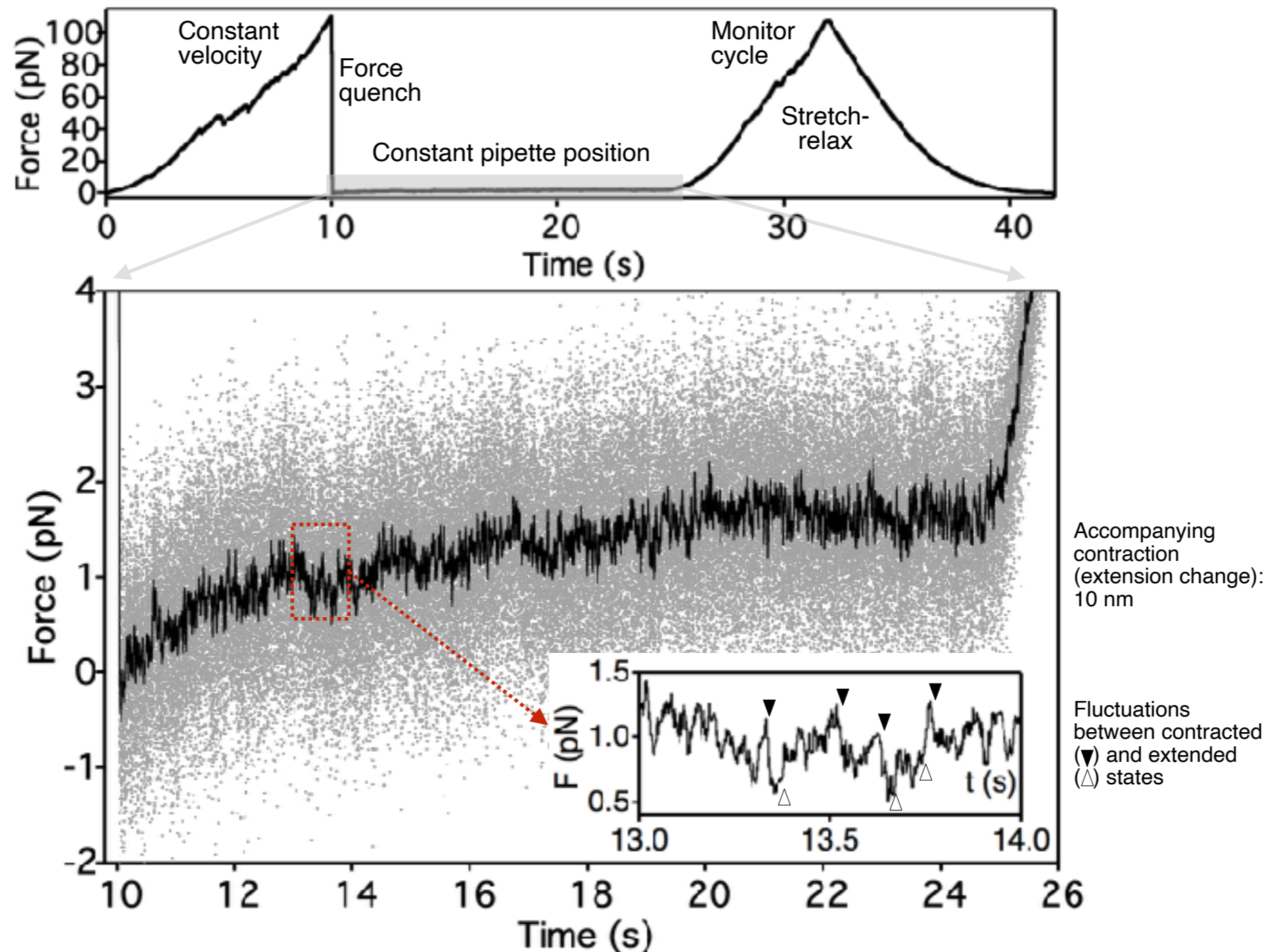

Molten-globule structure explored with sMDS

