

Special microscopic techniques

Dóra Haluszka, PhD



Brief history of microscopes

- 1st century: Romans were looking through glass and testing it
- 1600s: Zacharias Jansen - first telescope/compound microscope

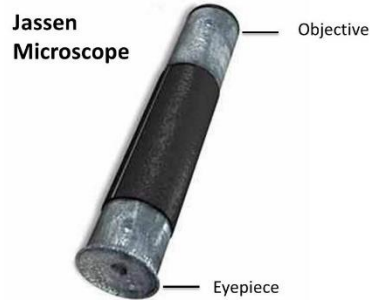

- 1667: Robert Hooke - „Micrographia” , cells of cork

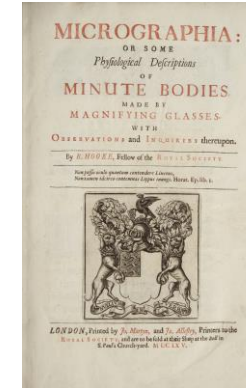
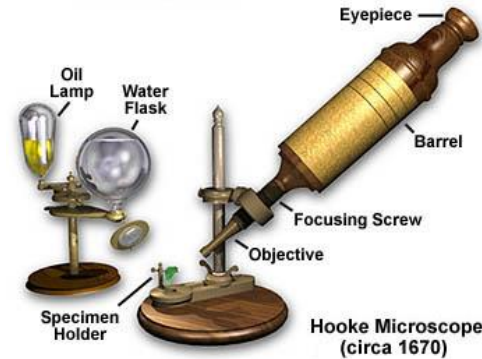

- 1674: Antonie van Leeuwenhoek - make simple microscopes, 270 x magnification

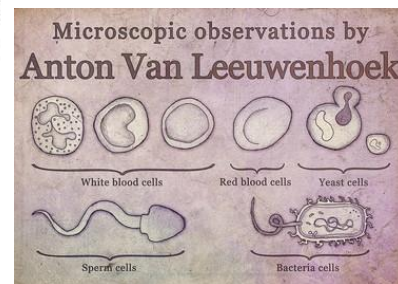
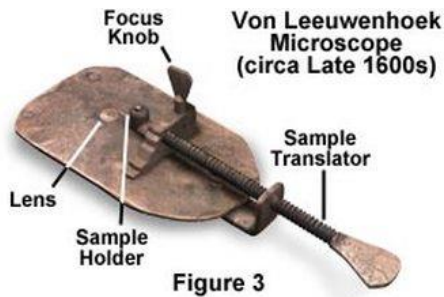
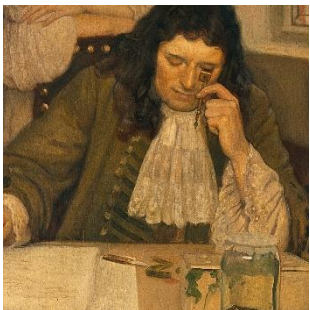

- Early 1800s
Carl Zeiss - businessman in Jena - development of high quality microscope
Ernst Abbe - He put the production of optical devices on scientific bases



Fundamentals of wave optics

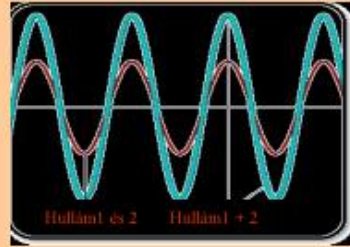

Similar phase
Constructive interference

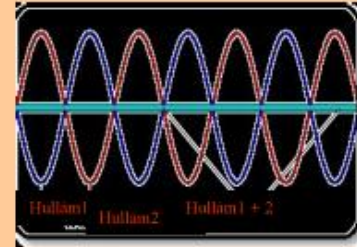

Opposite waves
Destructive interference



Young's experiment

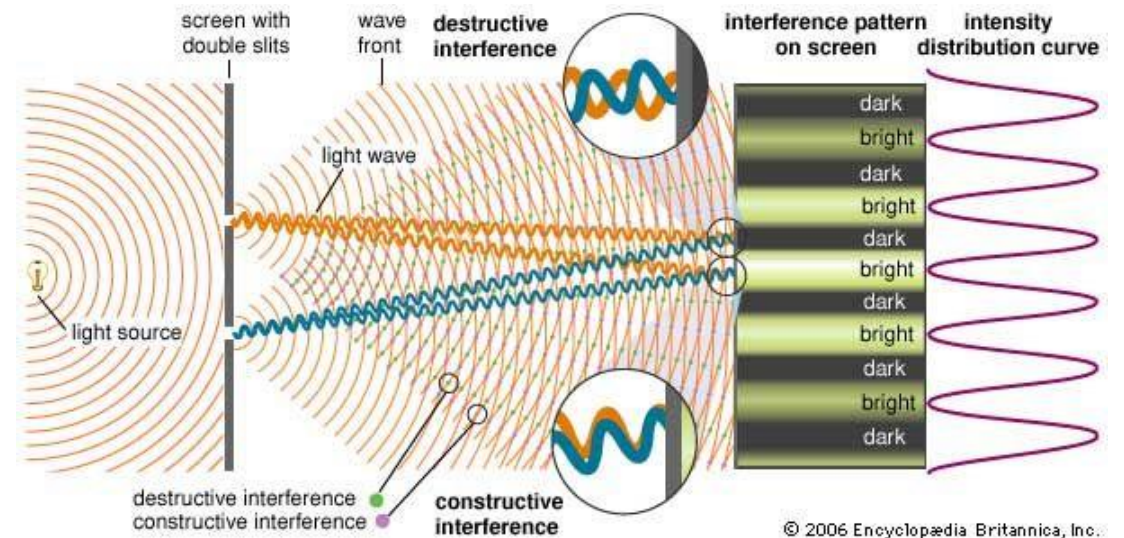

Resolution limit of microscope

1873: Ernst Abbe - resolution limit of light microscope

Abbe's principle: An optical system can resolve only those details of the specimen, which diffract light rays in a way that besides the principal maximum at least the first order diffraction rays are allowed to contribute to the image formation.

$$\delta = 0,61 \frac{\lambda}{n \sin \omega}$$

δ limit of resolution - distance between two object details which can be just resolved
(200 nm)

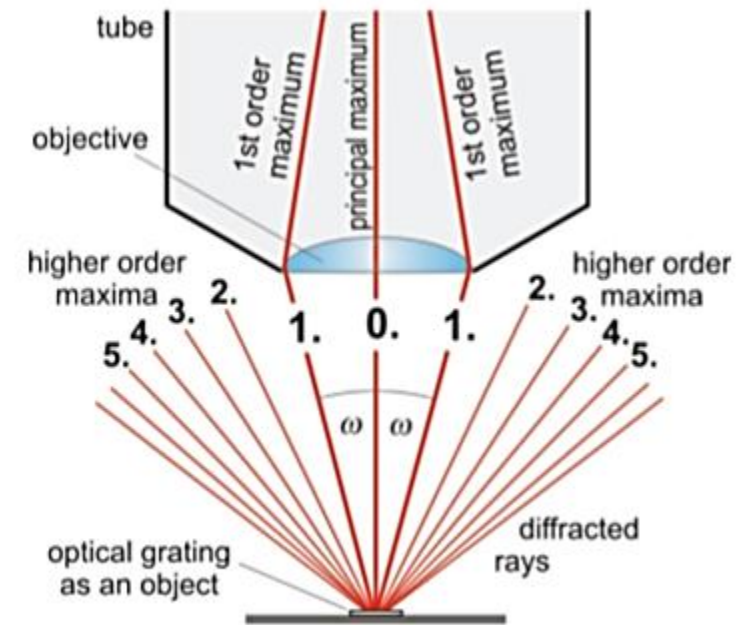

Ernst Abbe (1840-1905)

Airy disks - the evidence of wave character of light

The Airy disk is descriptions of the best-focused spot of light that a perfect lens with a circular aperture can make, limited by the diffraction of light.

Formation: the waves in same phase produce diffraction maximum (left) while the waves shifted by 180° produce diffraction minimum (right).

Point Spread Function (PSF): intensity distribution of diffracted waves

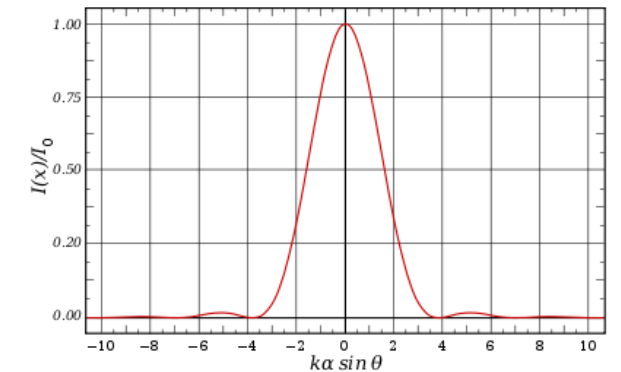
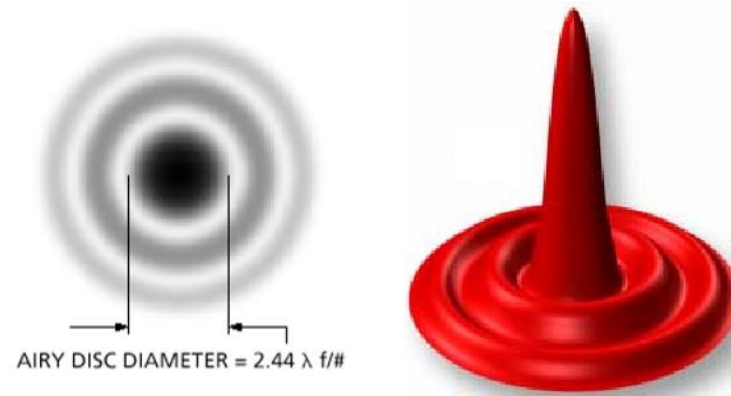
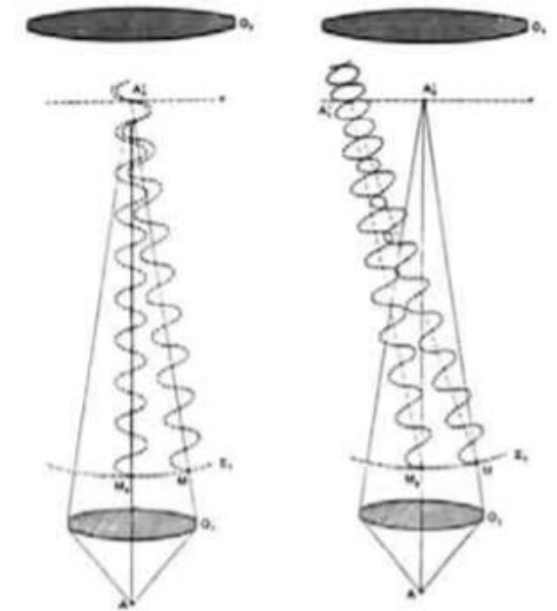
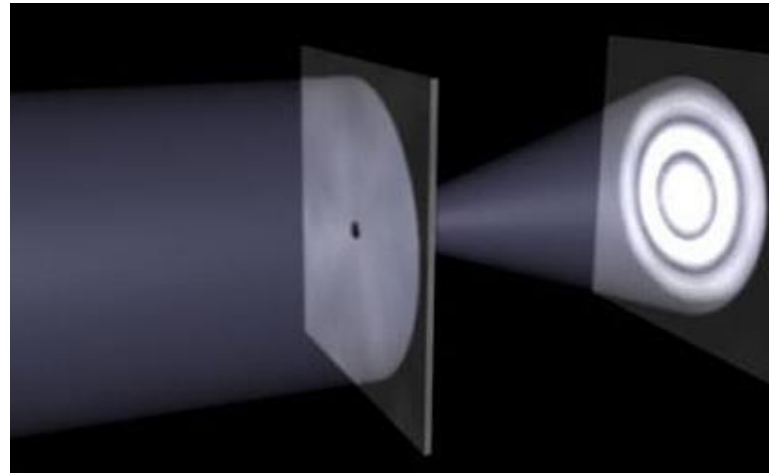

How can we distinguish two image points?

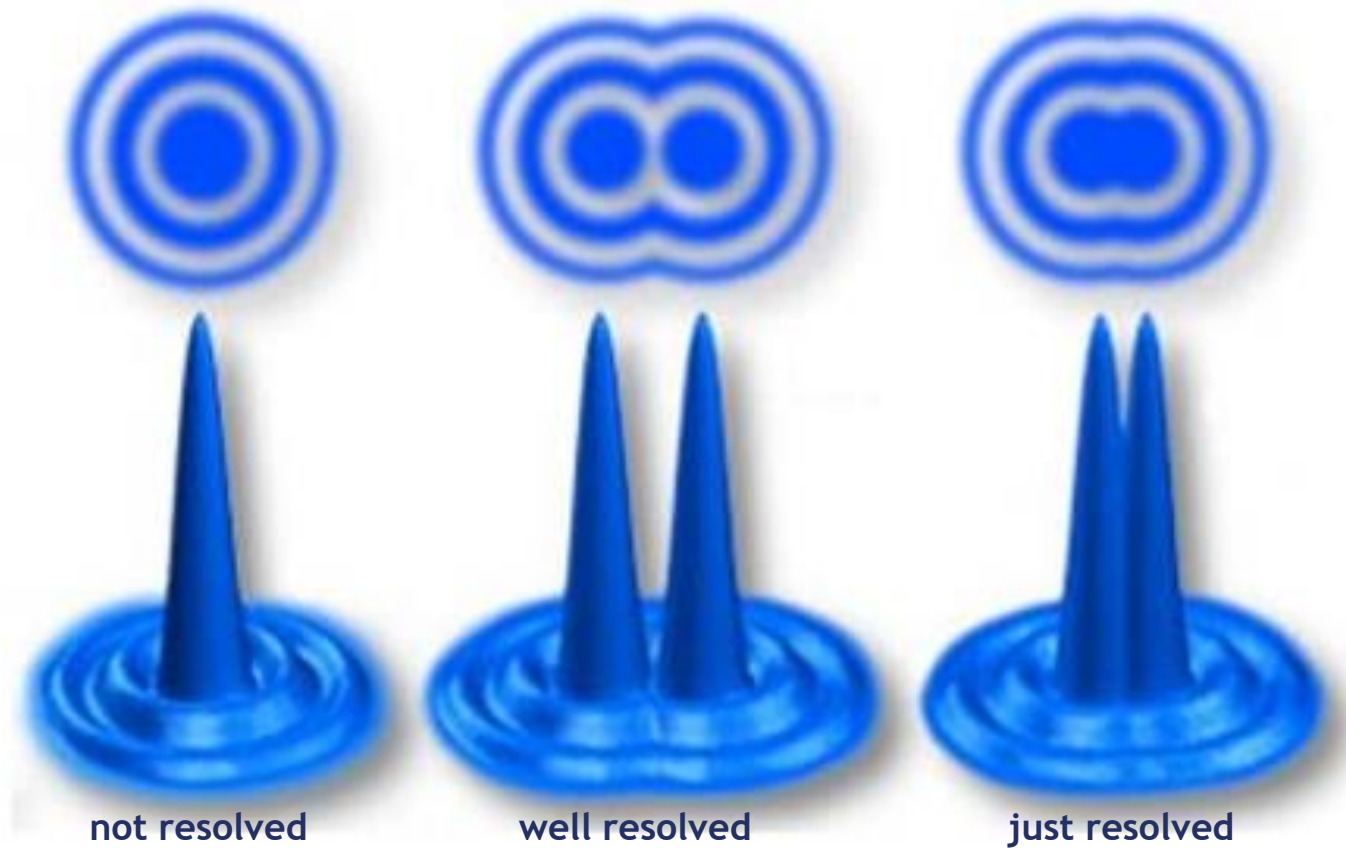

Rayleigh criterion:

Objects may be resolved if their corresponding Airy disk do not overlap.

Just resolved: principal maximum of one image point coincides with the first order minimum of the other

Fluorescence

Jablonski diagram

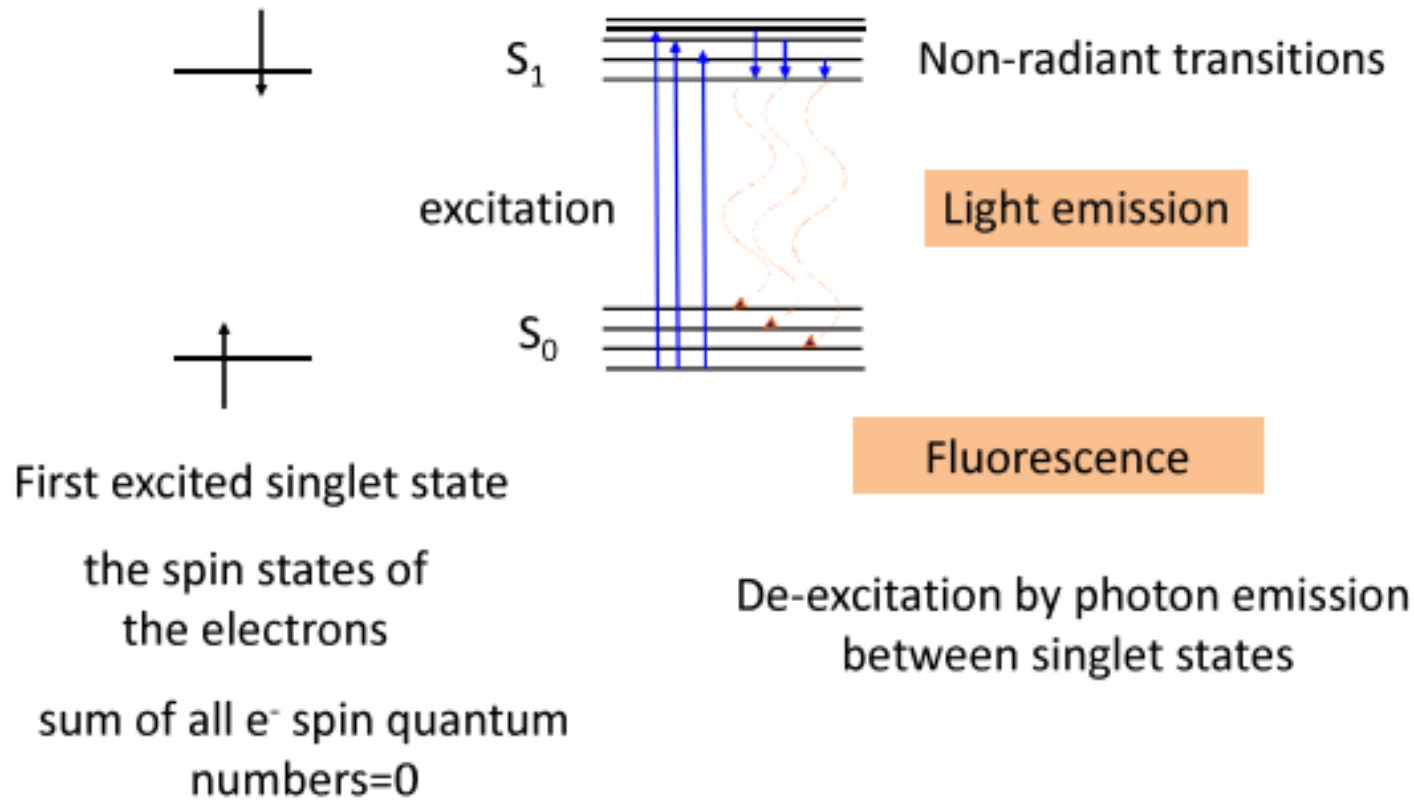

$$E_{\text{excitation}} \geq E_{\text{fluorescence}}$$

$$\lambda_{\text{excitation}} \leq \lambda_{\text{fluorescence}}$$

Stokes-shift



Kasha's rule: light emission emanates from the relaxation of the lowest vibrational level of the first excited state to ground state.

Fluorescence microscope

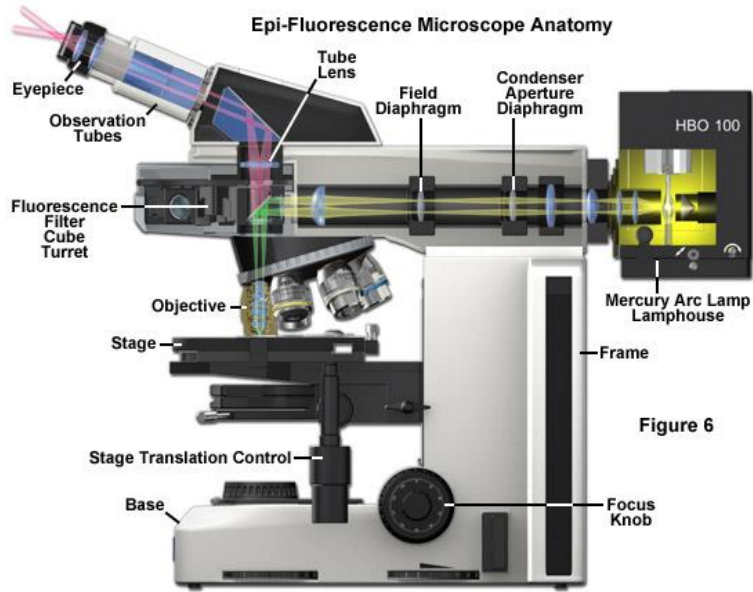

Figure 6

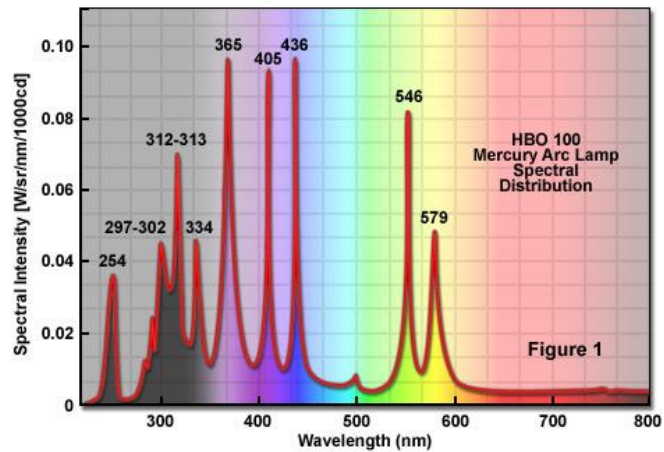
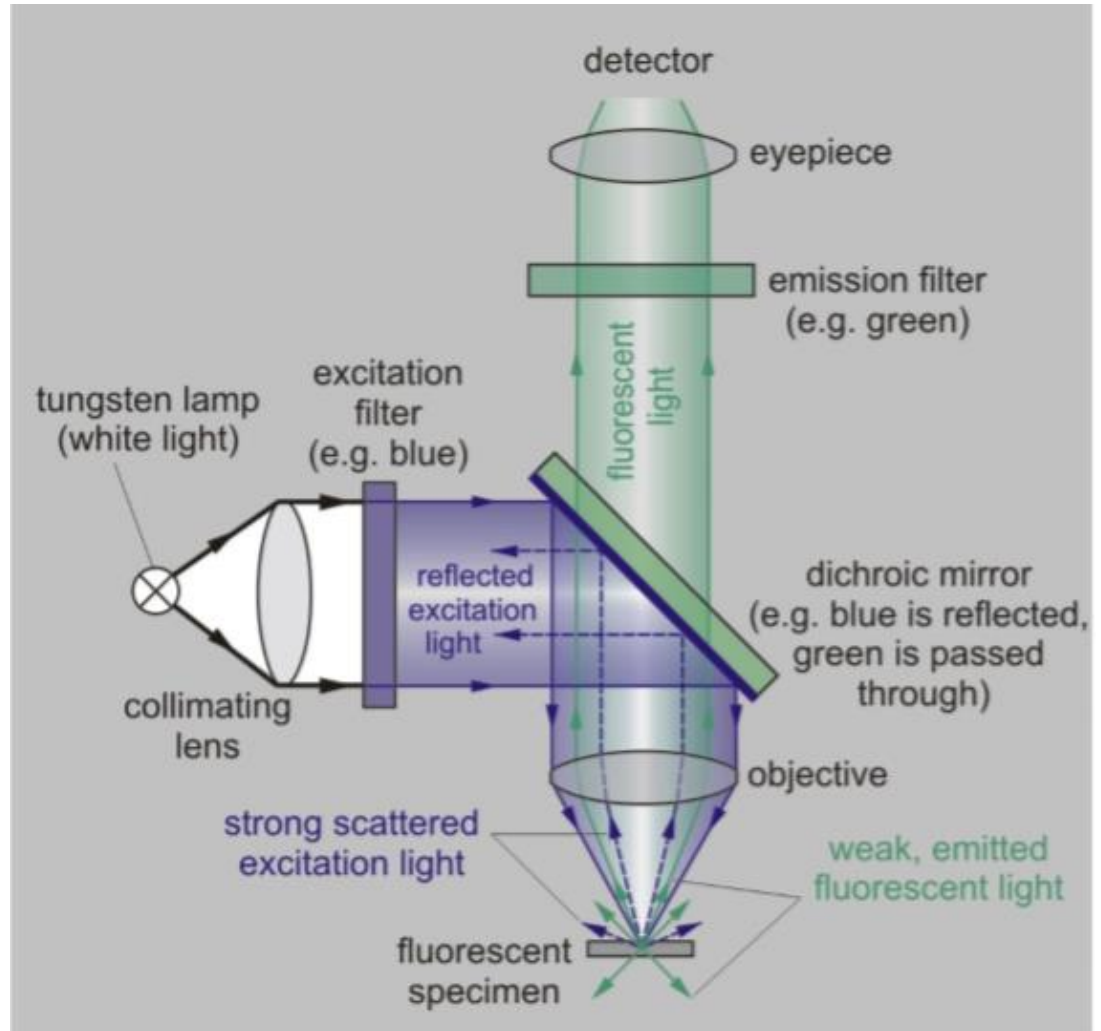
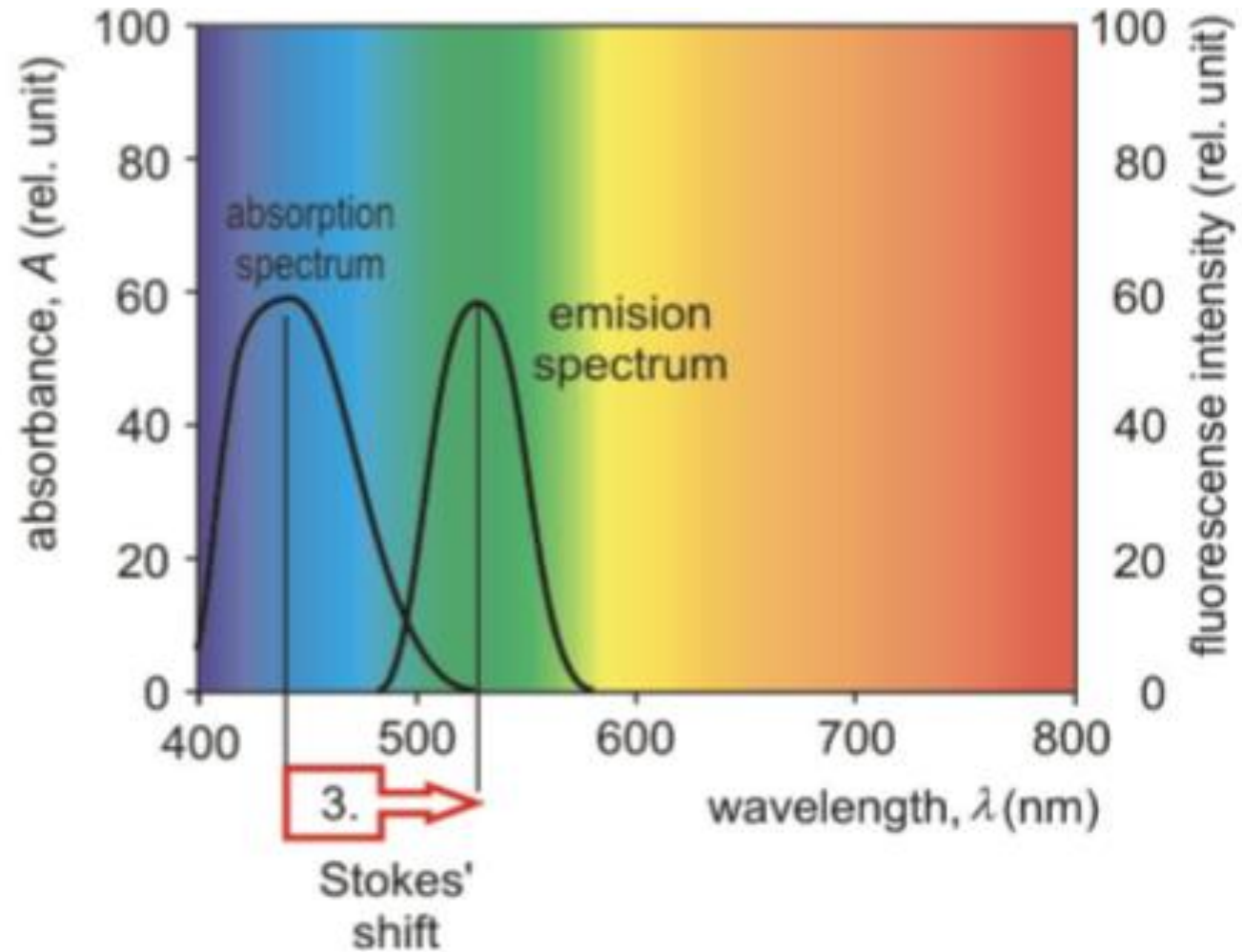

Figure 1



Absorption and emission spectrum



Source of fluorescence

- **Intrinsic fluorophores:**
tryptophan, tyrosine aminoacids
(aromatic) porphyrins
- **Extrinsic fluorophores:**
fluorescent dyes

The perfect fluorescent dye:

- Small
- Hydrophil
- Can be excited in the visible range
- Large Stokes-shift
- Specific
- No photoreactions

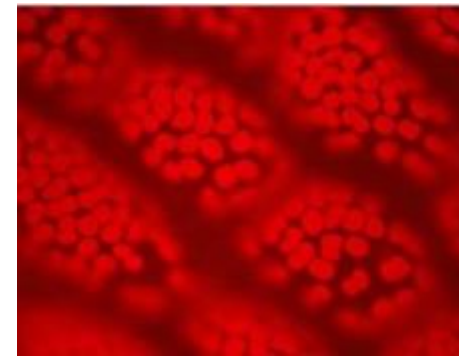
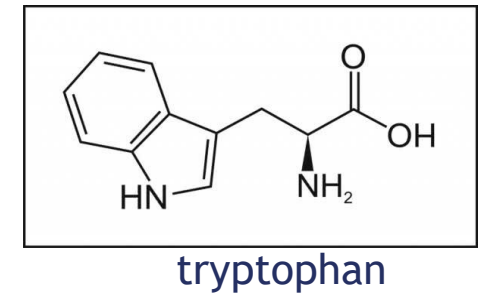
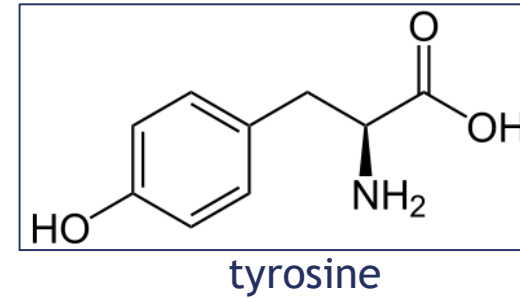

porphyrin fluorescence

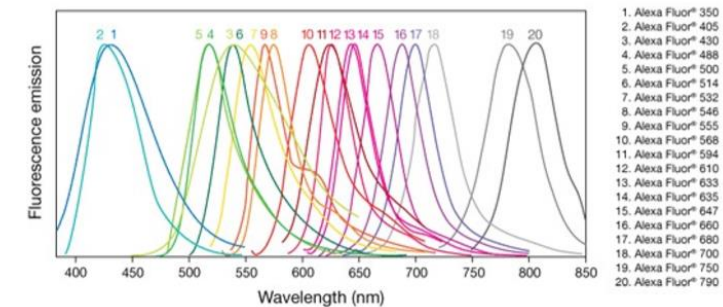
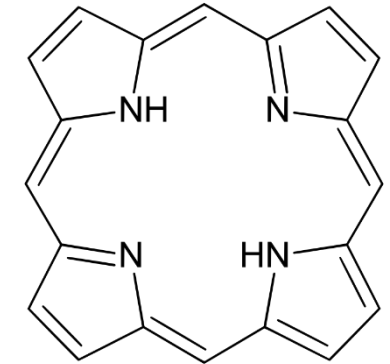

Fluorescent proteins

- Green Fluorescent Protein (GFP)
- first isolated from jellyfish (1960s)
- ~27 kDa, 238 aa, 11 strands β -barrel structure
- the central alpha helix contains the chromophore: Ser-65, Tyr-66, and Gly-67
- excitation: blue (475 nm) and UV (396 nm) light
- emission: 508 nm
- Used as tagging protein
- Small size - has no effect on the function of examined protein
- Transfected cells
- Transgene animals: all cell express the GFP



Aequorea victoria

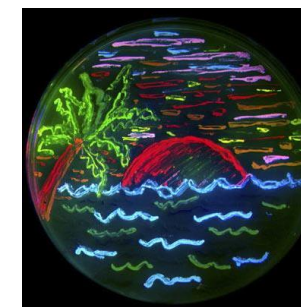
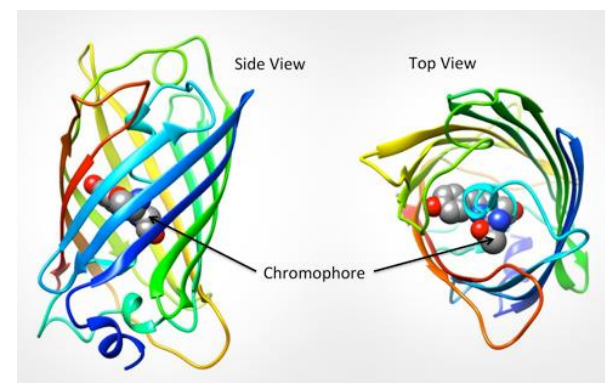



Transgene mice

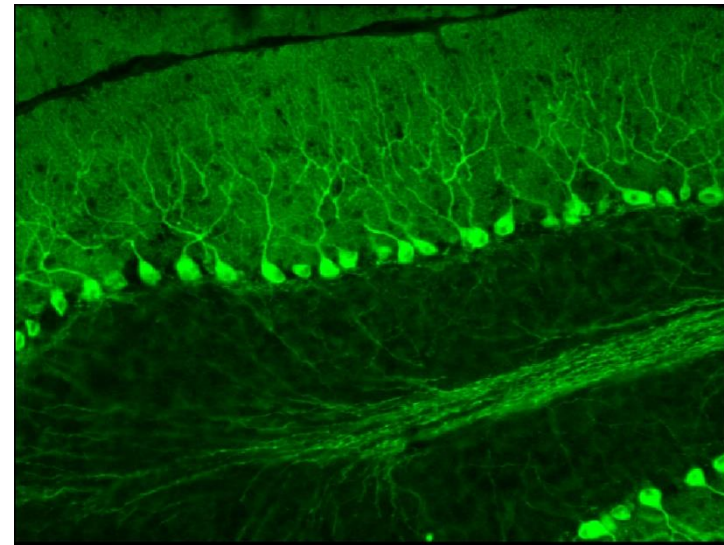

Purkinje cells



Frog muscle cells

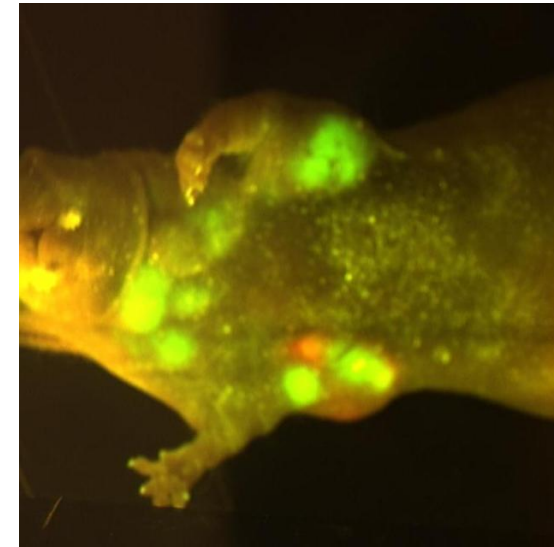

Tumor cells

2008. Nobel prize in chemistry

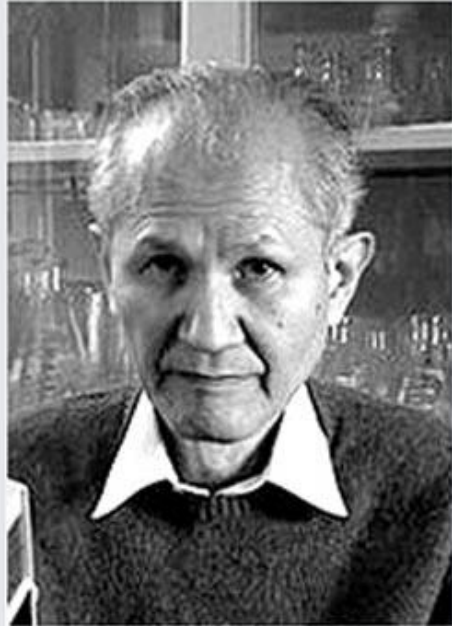

Photo: J.
Henriksson/SCANPIX

Osamu Shimomura



Photo: J.
Henriksson/SCANPIX

Martin Chalfie



Photo: UCSD

Roger Y. Tsien

General properties of lasers

light **a**mplification by **s**timulated **e**mission of **r**adiation



- monochromatic
- coherent
- polarized
- parallel, collimated beam

Possibility of very short pulses – *ps*, *fs*

Possibility of high power – *kW* - *GW*



Penetration of light into the skin

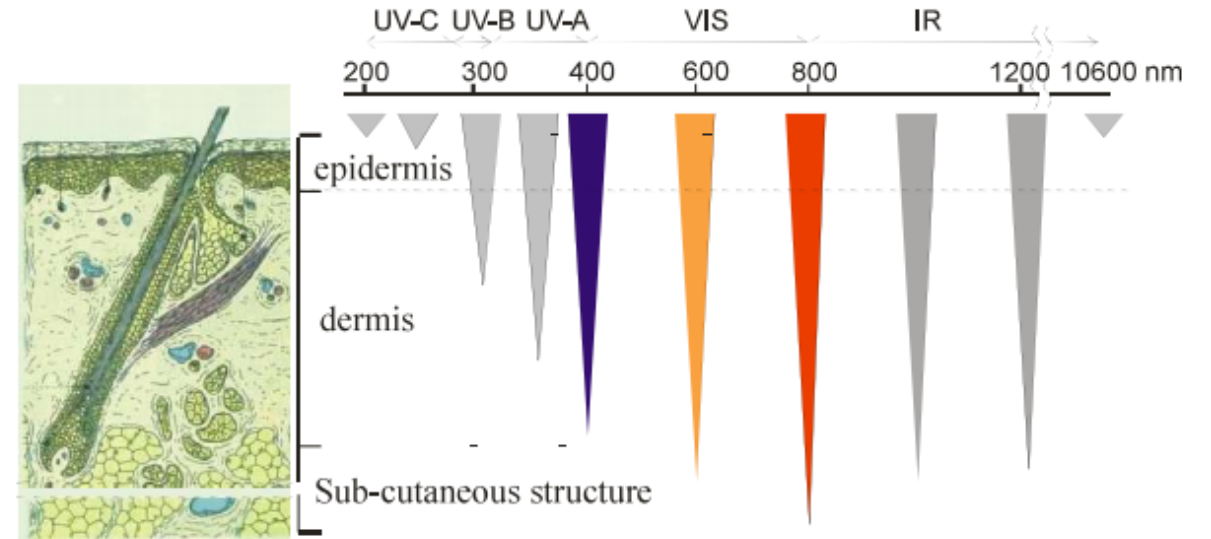

Light intensity is attenuated due to absorption, reflection, refraction.

Penetration depth depends on the wavelength.

Confocal laser scanning microscope

Confocal concept: a focused laser beam is used to produce a small spot illumination on the specimen, and a pinhole in front of the detector eliminates out-of-focus signal

- laser beam - focused illumination
- excitation filter - selected wavelength
- point-by-point scanning
- motorized XY scanning
- „optical sectioning”
- 3D imaging

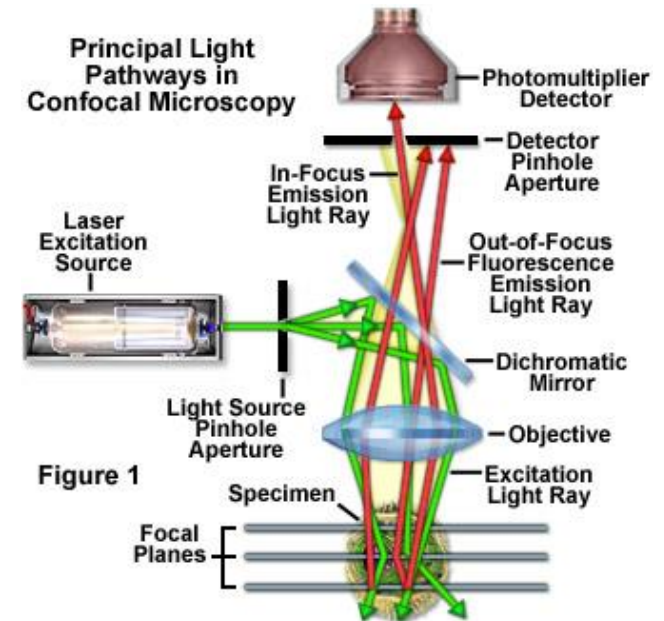
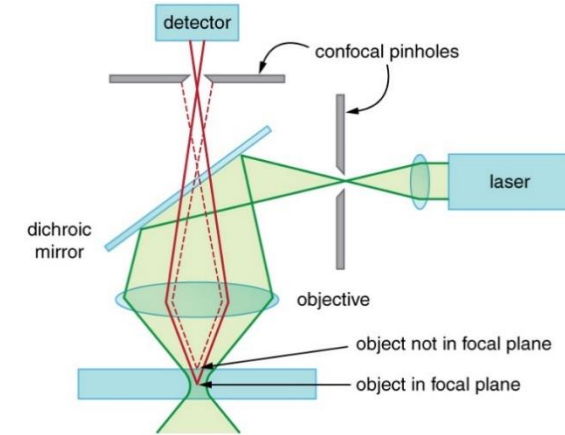

Comparison the imaging of fluorescence and confocal microscopes

Confocal and Widefield Fluorescence Microscopy

fluorescence

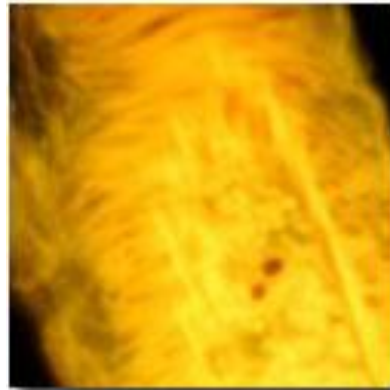

(a)

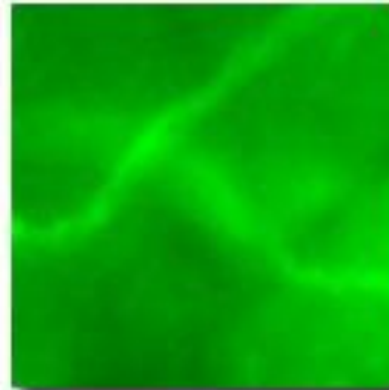

(b)

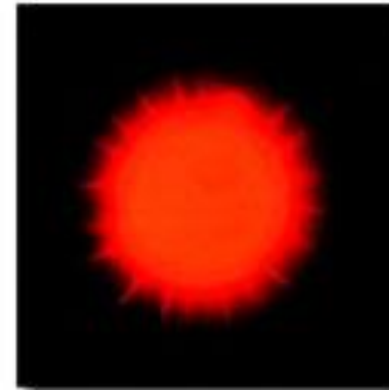

(c)

confocal

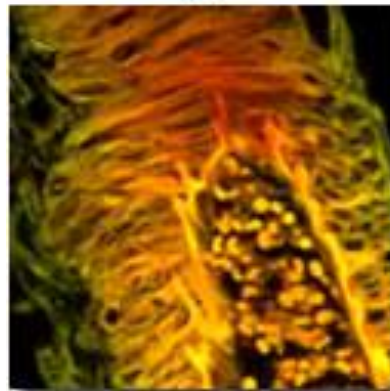

(d)

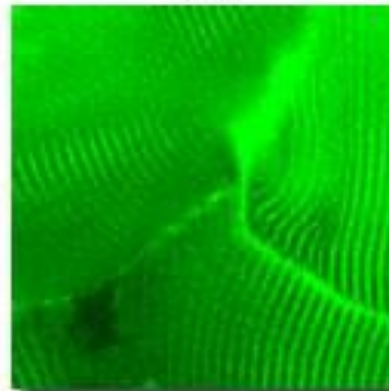

(e)

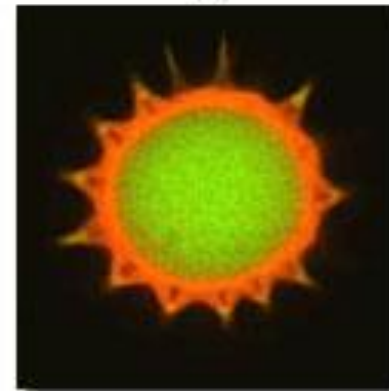

(f)

human medulla

muscle

Figure 1

pollen

Two-photon microscopy

- 1931. Maria Göppert-Mayer
- in the excited molecule two photons absorb simultaneously
- femtosecond laser source ~ high flux of excitation photons
- 1990. first two-photon excitation microscope
- Wienfried Denk, Cornell University



Maria Göppert-Mayer (1906-1972)

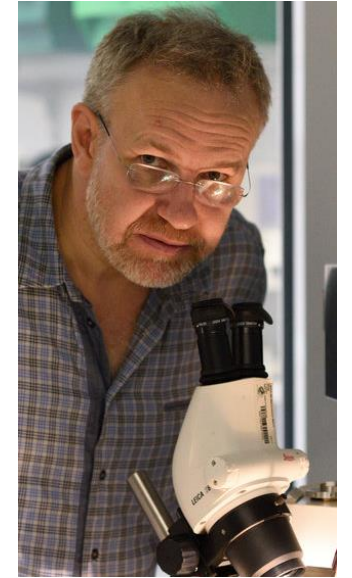

Wienfried Denk (1957-)

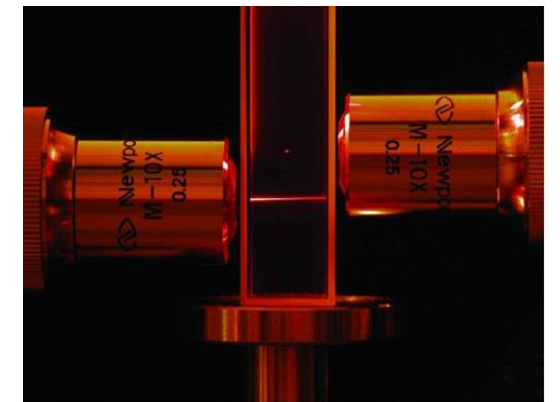
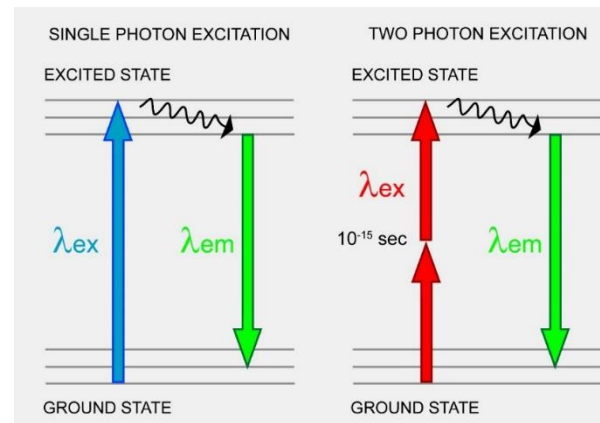

Light absorption and emission spectrum

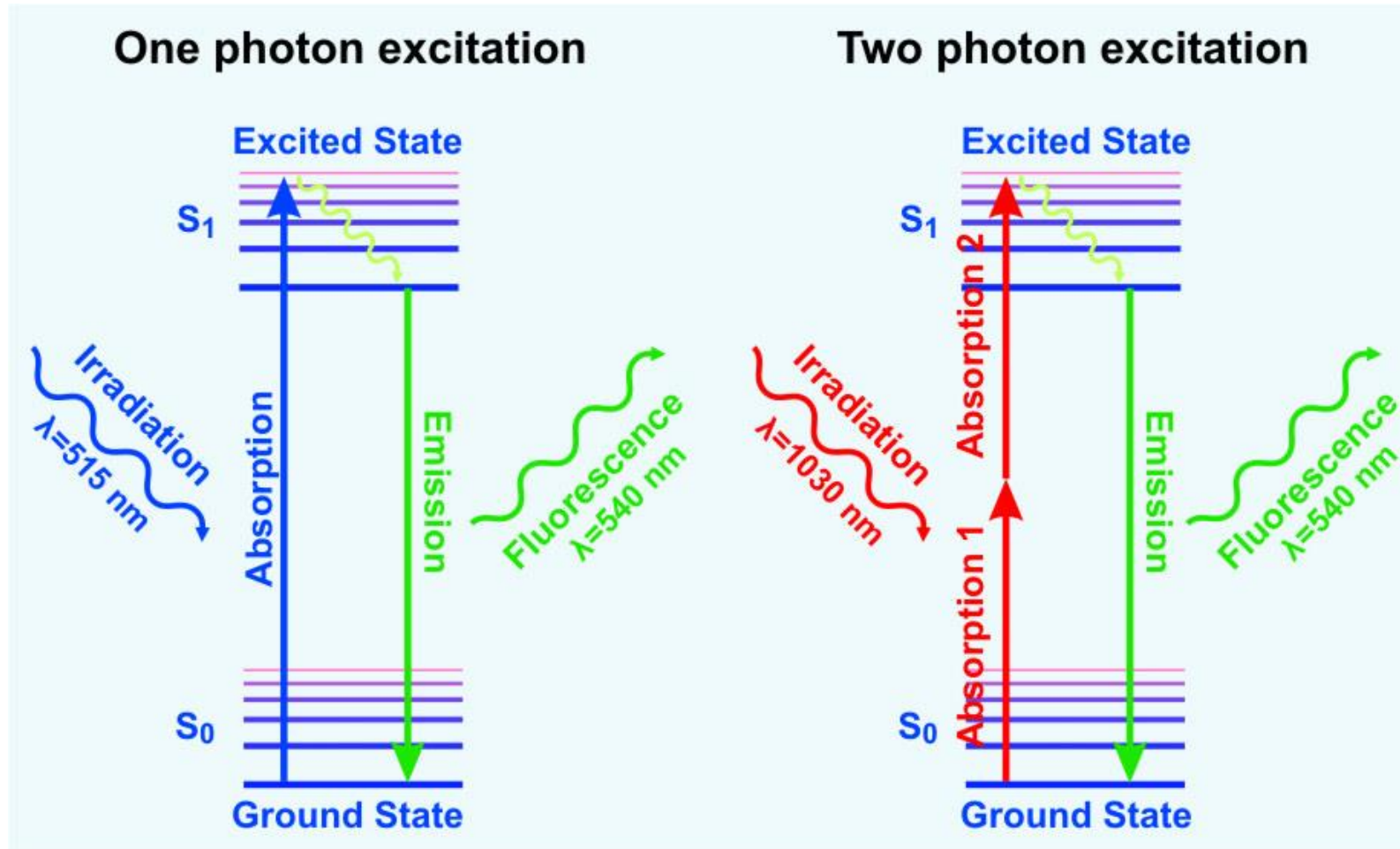

Advantages

- excitation only in a tiny focal volume - reject out-of-focus
- low laser power - *in vivo* imaging
- infrared spectral range of laser source (700-1300 nm) - reduced scattering
- deep penetration
- effective signal detection
- optical sectioning - 3D imaging
- imaging without labeling

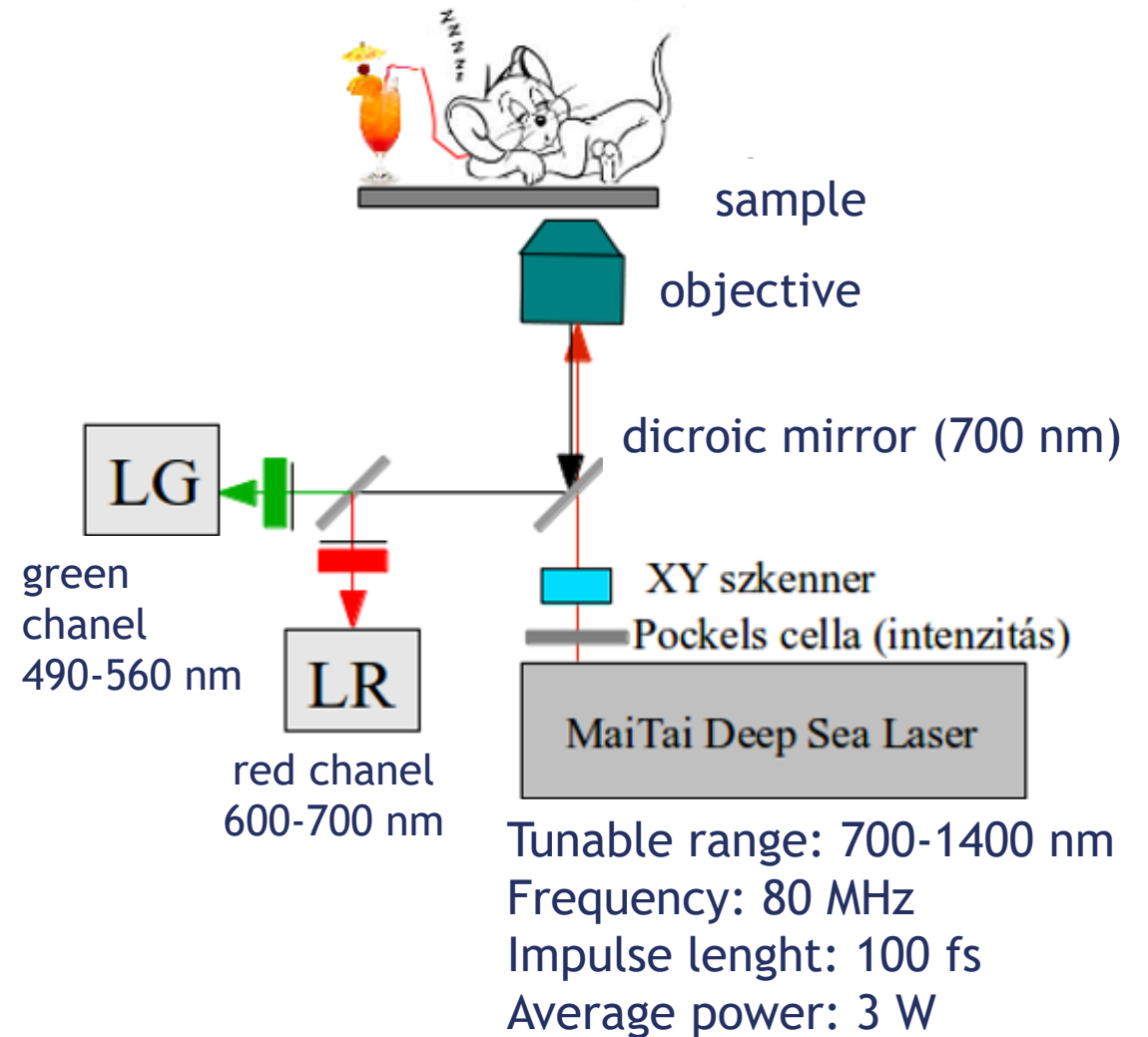

Label-free imaging

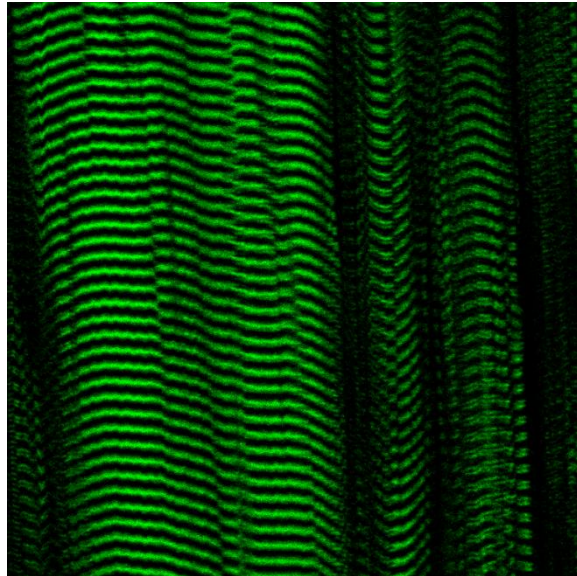

myosin

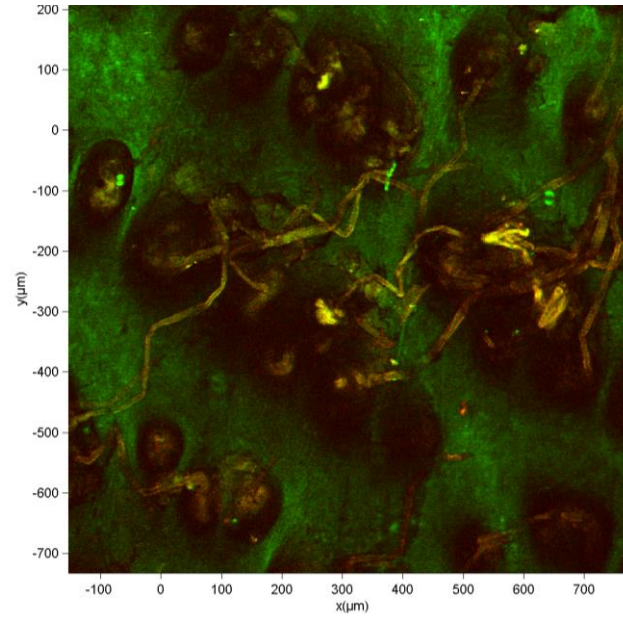

mice skin

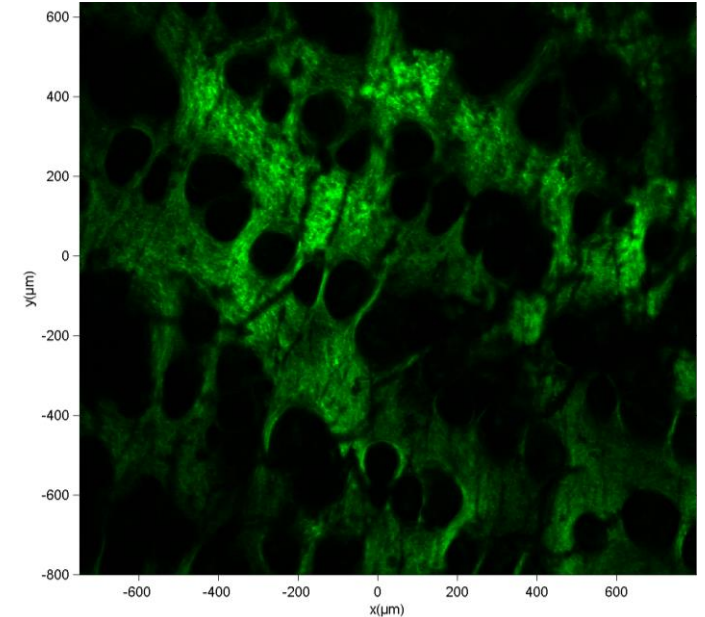

mice dermal collagen

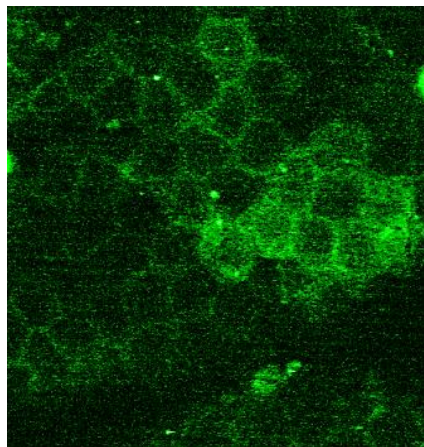

mice skin - keratin

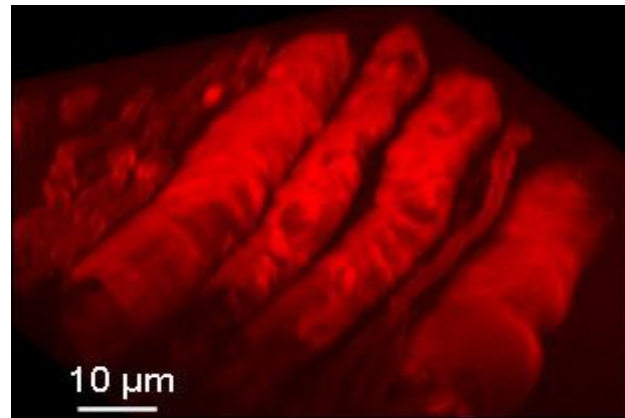

myelin sheaths

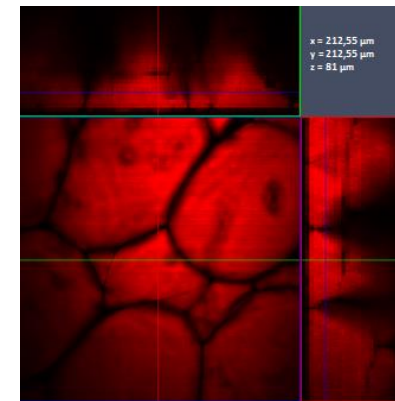

adipocytes

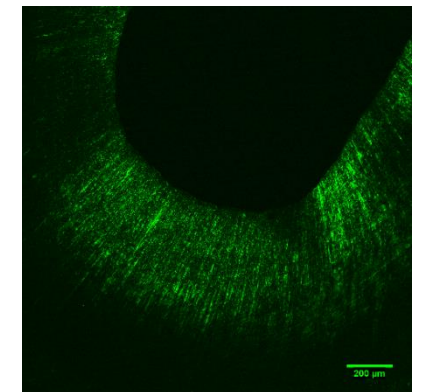

dental tubules

3D imaging

Comparison the dermal collagen structure of a control and type 2 diabetes affected mice

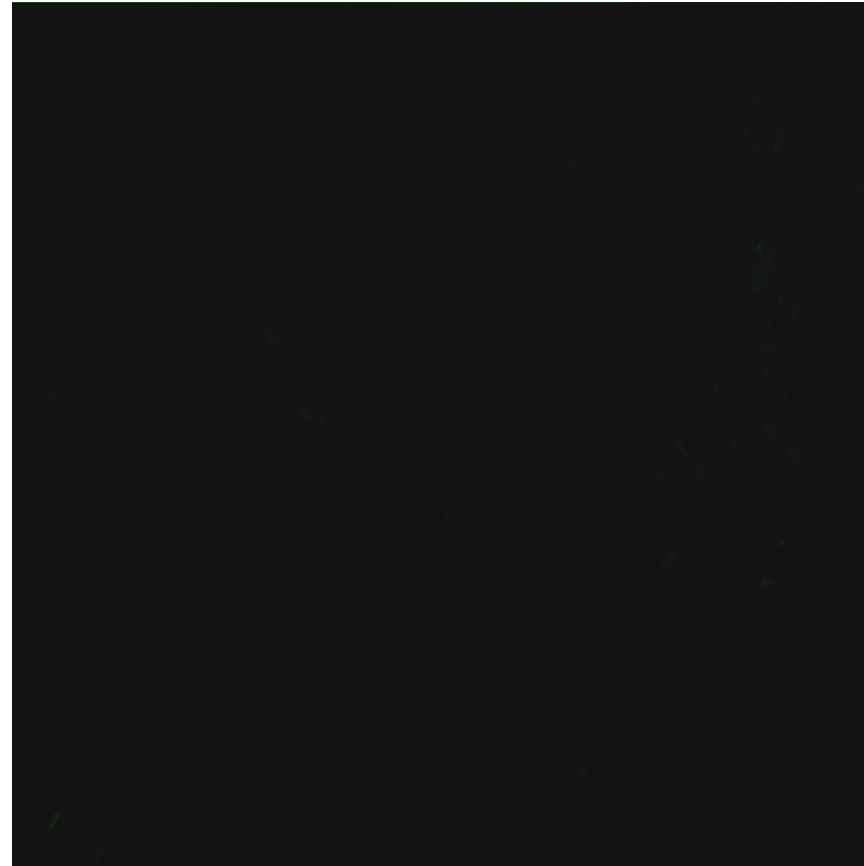

Optical sectioning,
z = 80 μ m
200 μ m x 200 μ m
exc: 990 nm

In vivo clinical application

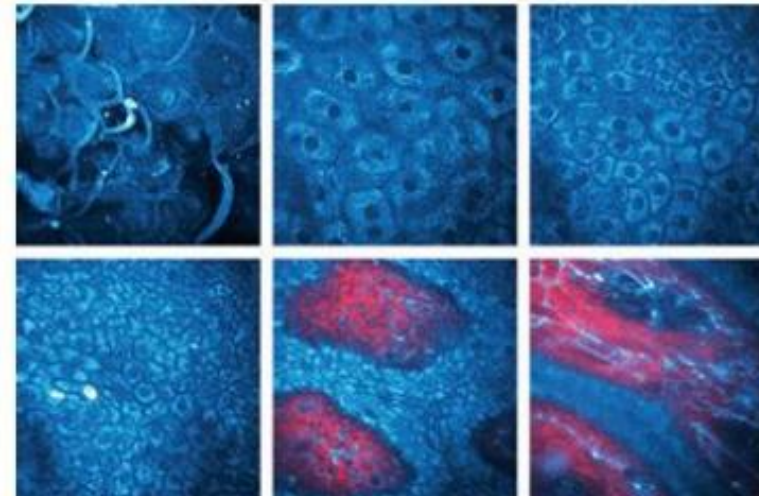

El Madani HA, Tancrede-Bohin E, Bensussan A, Colonna A, Dupuy A, Bagot M, Pena AM. (2012) In vivo multiphoton imaging of human skin: assessment of topical corticosteroid-induced epidermis atrophy and depigmentation. *J Biomed Opt*, 17(2)

How big are things?

resolution limit: **200 nm**

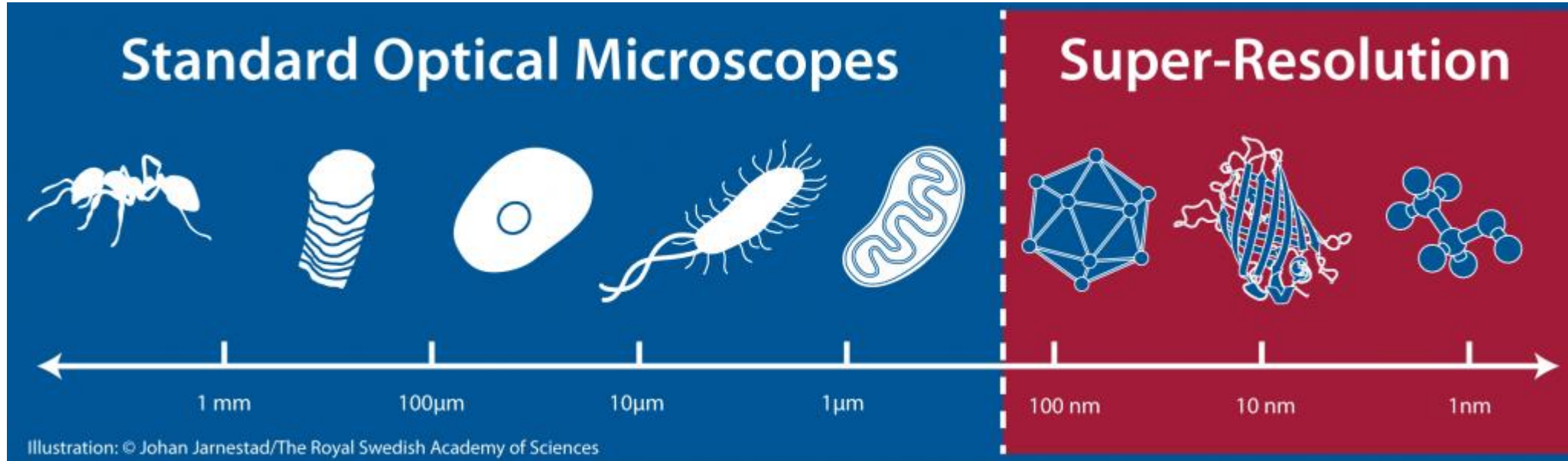

Superresolution microscopy

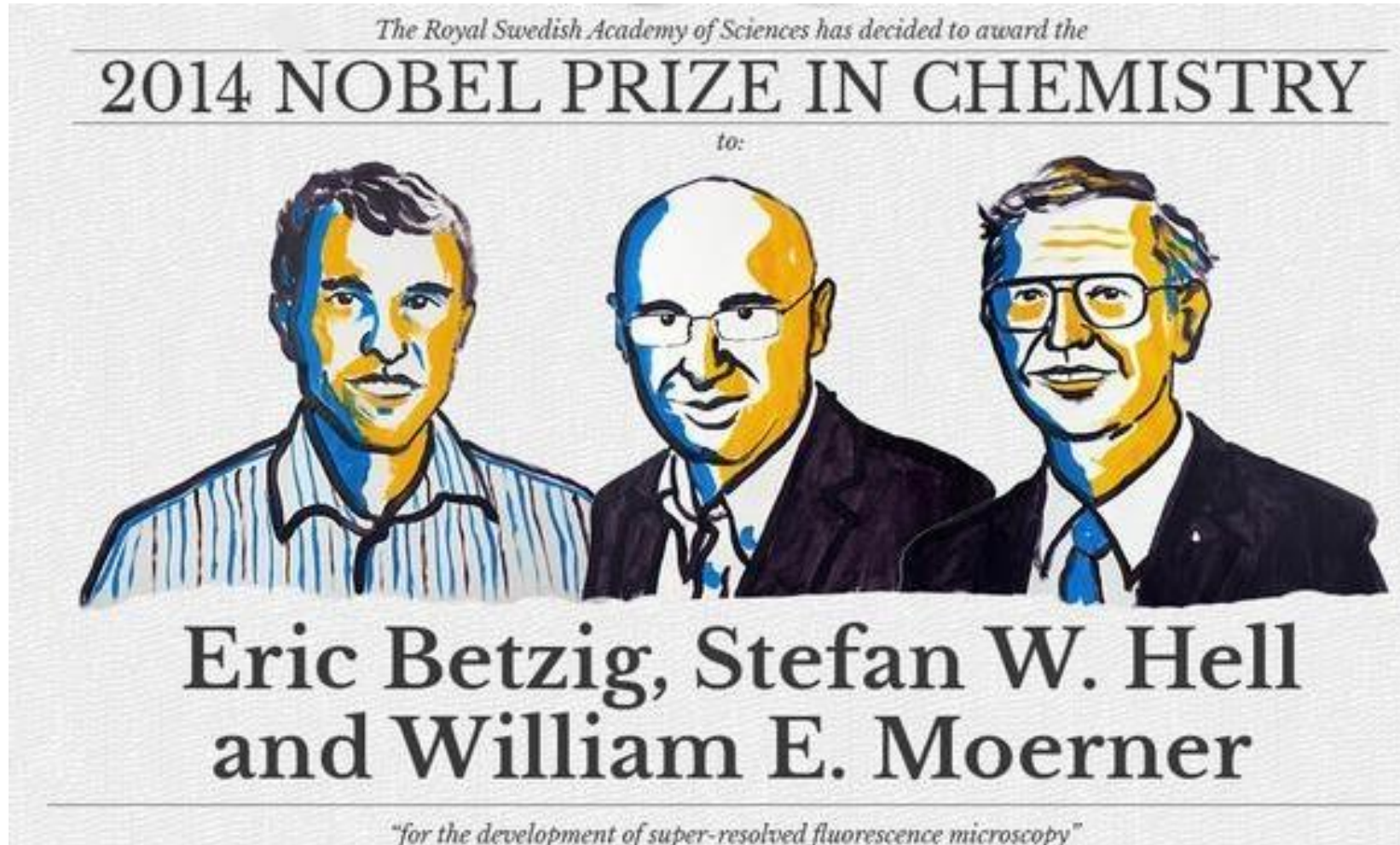

Superresolution microscope

- 2014. Eric Betzig, Stefan W. Hell és William E. Moerner were awarded Nobel-prize in chemistry
- STED: stimulated emission depletion microscopy
- 2018. August - STED device arrived in our Institute
- allows for images to be taken at resolutions below the diffraction limit
- Stimulated emission: this is a process by which an incoming photon of a specific wavelength can interact with an excited atomic electron causing it to drop a lower energy level
- Phase, frequency, polarization, and direction of the photons emitted with the stimulated emission are identical with that of induced the stimulation -> no contribution in image formation

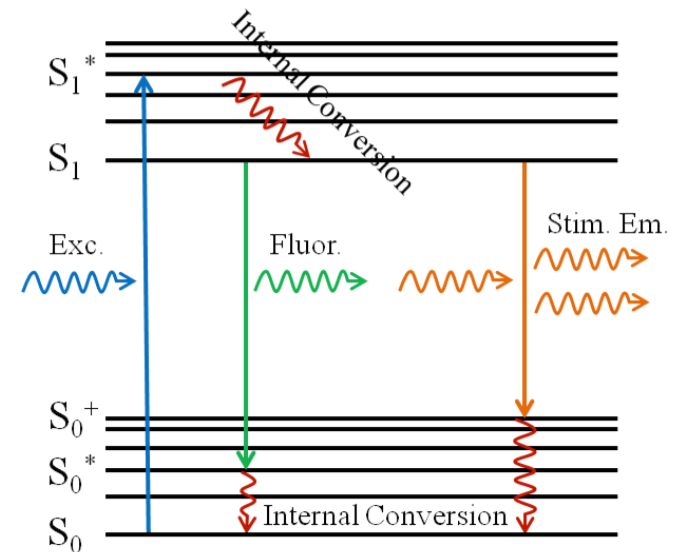
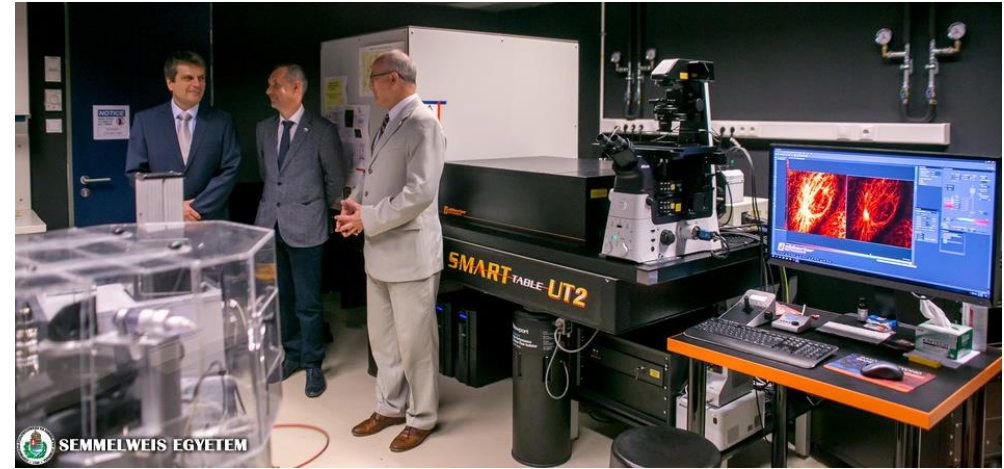

- excitation laser: produces an ordinary diffraction limited focus
- depletion laser: doughnut shape, fluorescence from the molecules is quenched via stimulated emission
- point-by-point scanning

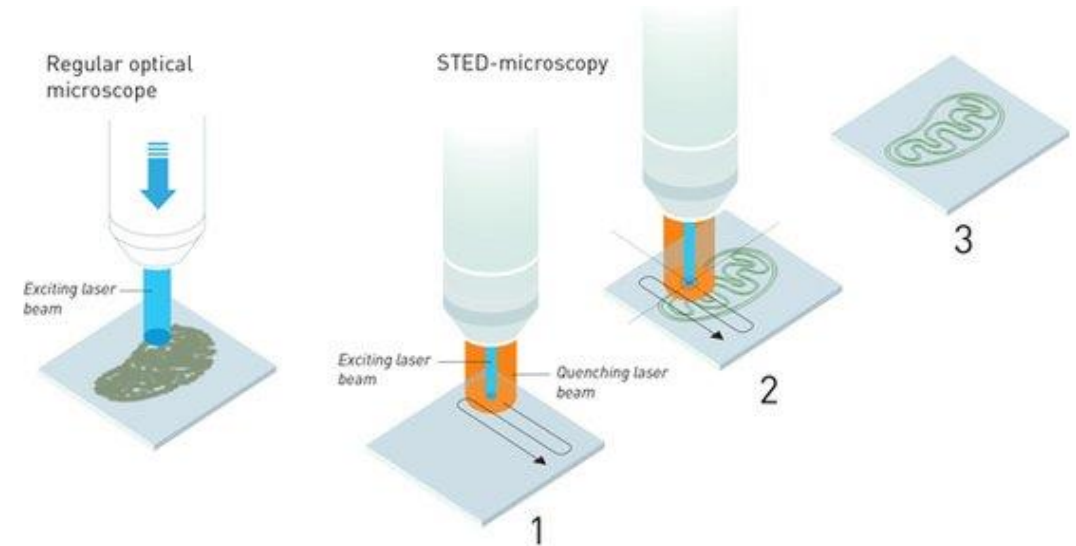
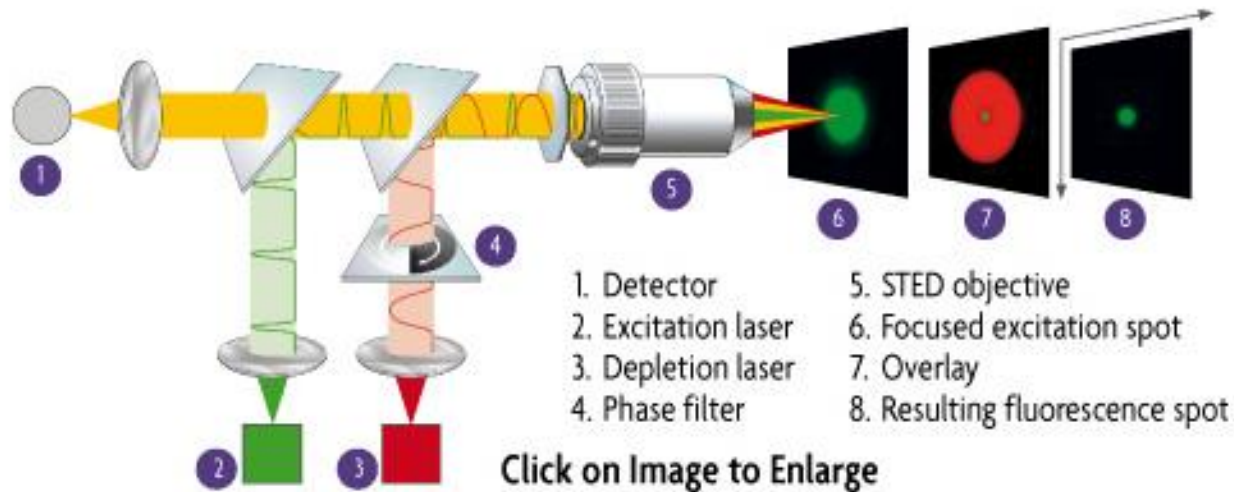
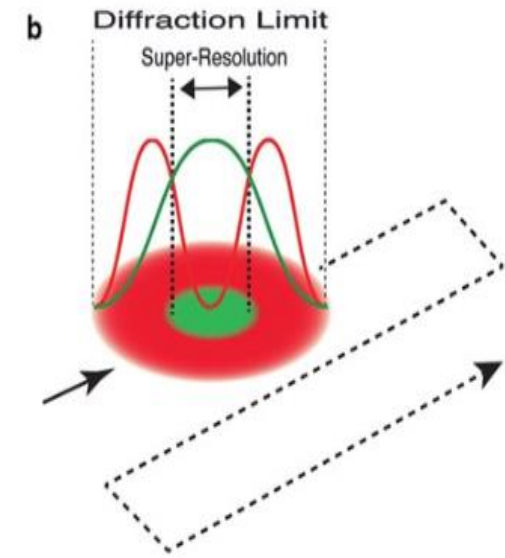

Vimentin: flexible intermediate filaments in the cytoskeleton

confocal

STED

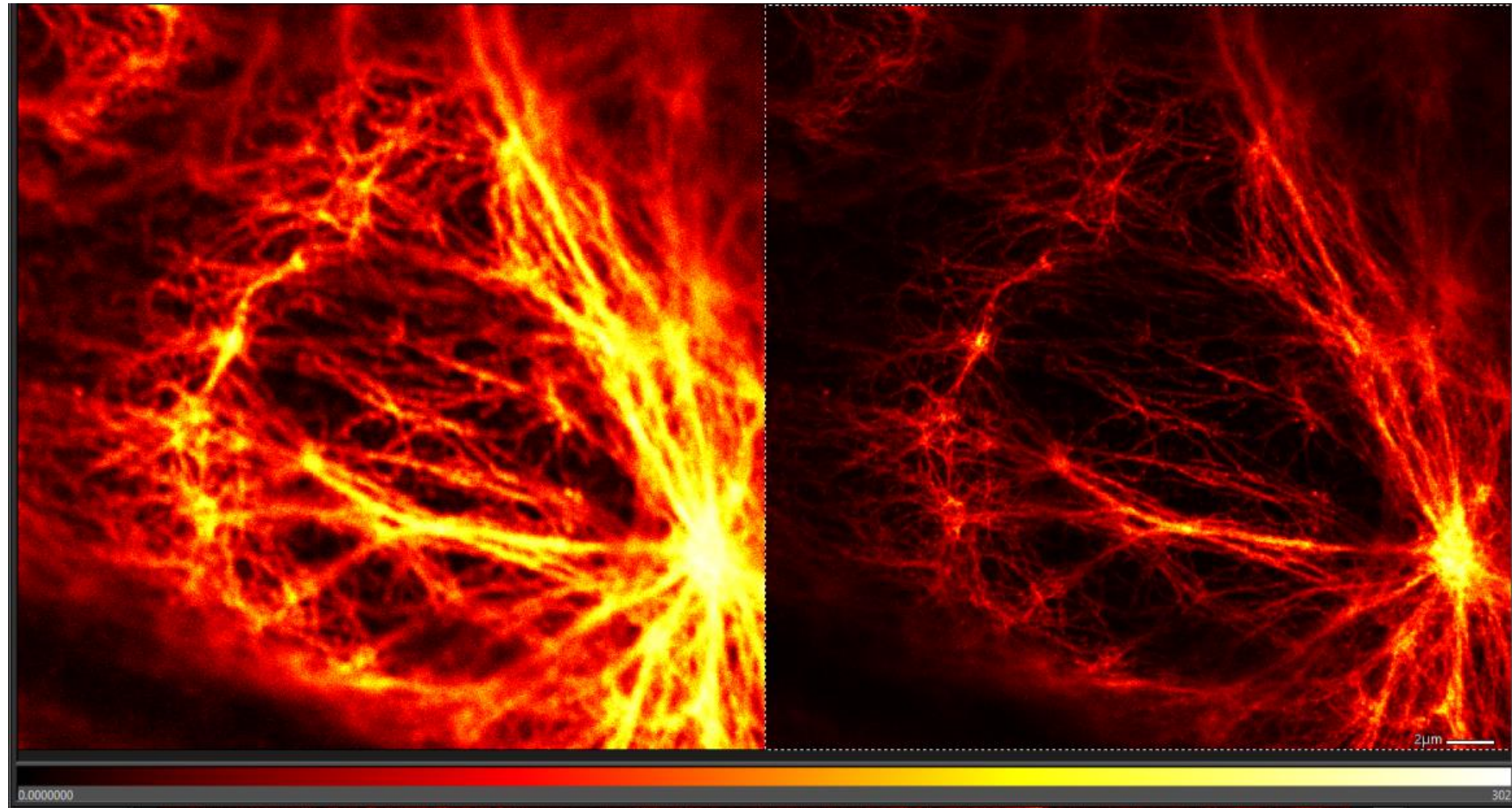

Nuclear pores of HeLa cells

confocal

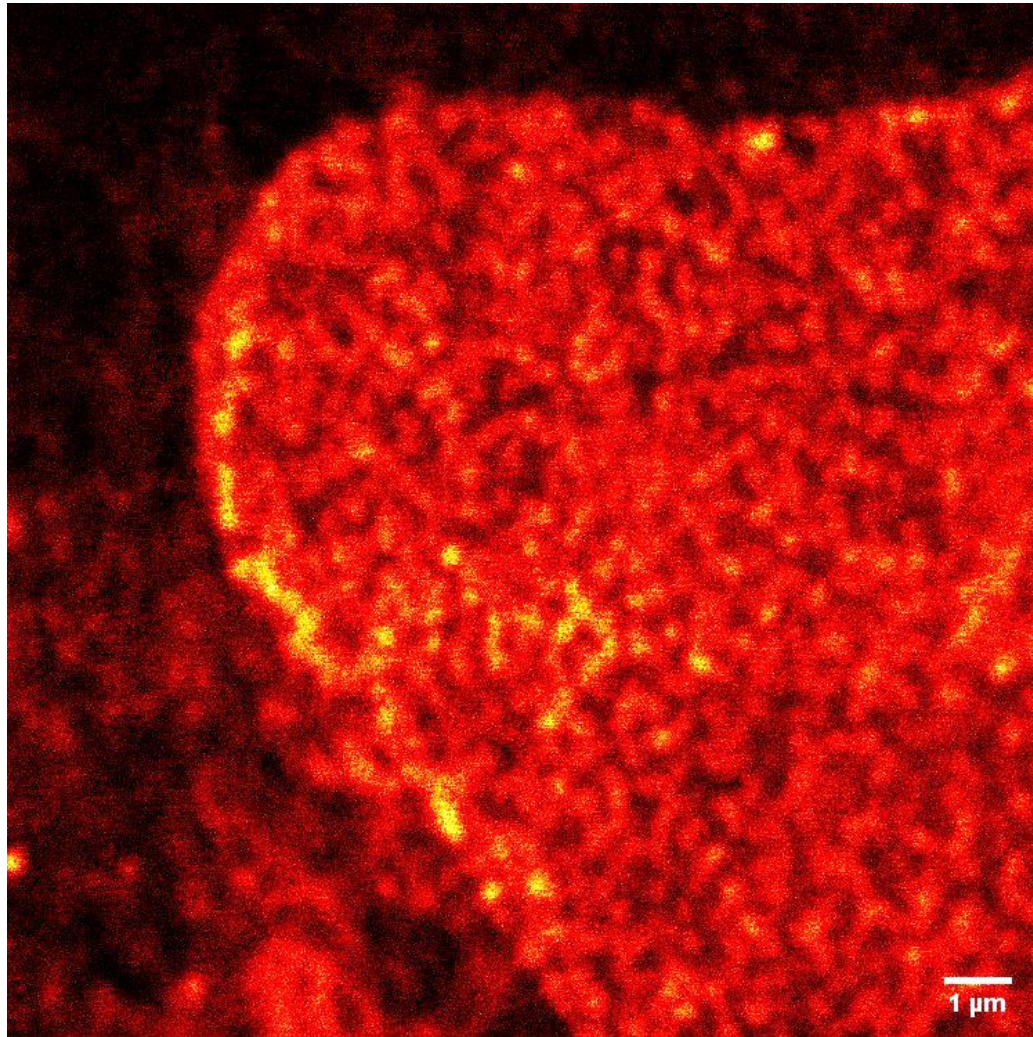

STED

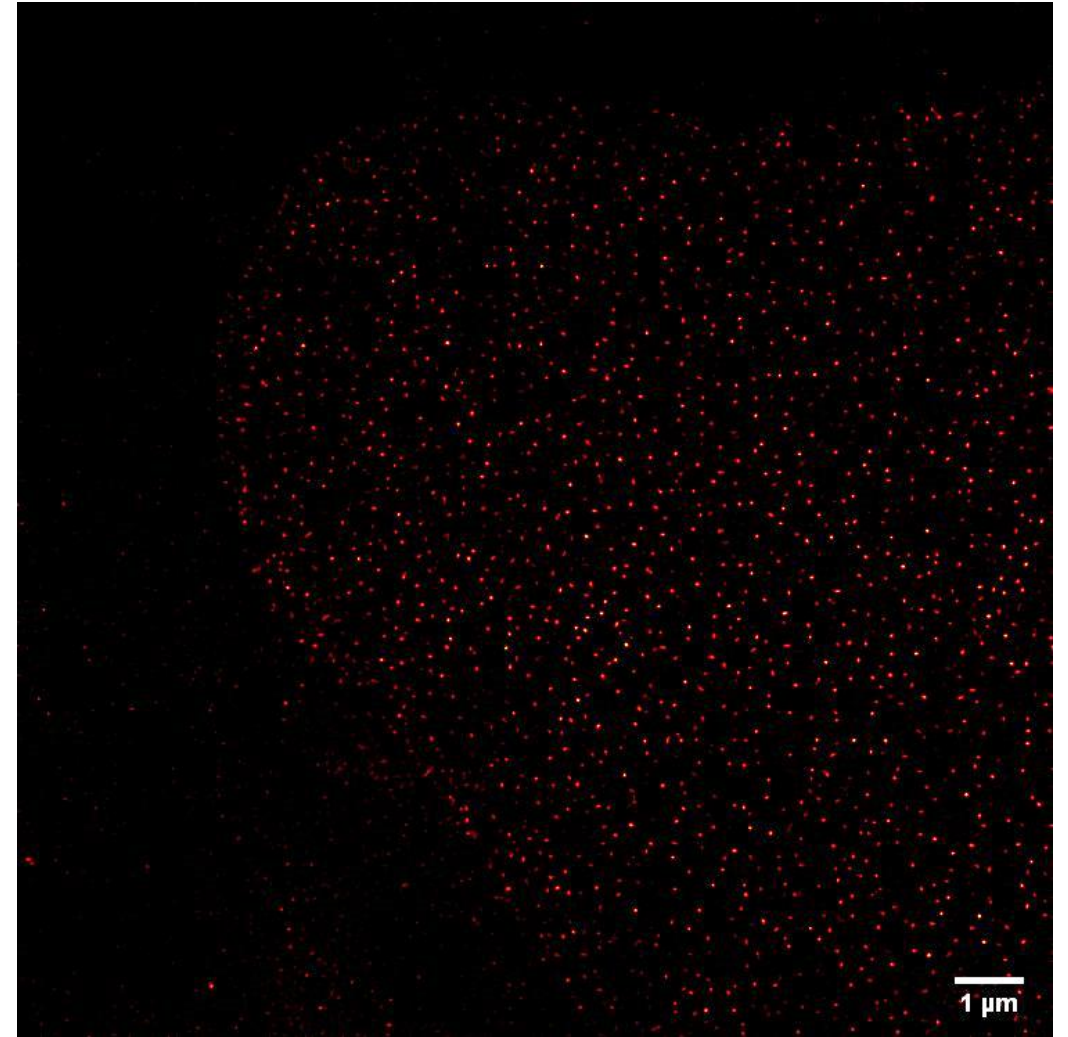

Checklist

- ✓ resolution limit of image formation
- ✓ Abbe's principle
- ✓ working principle of fluorescence microscope: illumination, excitation/emission spectra, Stokes-shift, function of dichroic mirror
- ✓ sources of fluorescence: intrinsic, extrinsic
- ✓ GFP protein
- ✓ working principle of confocal microscope: illumination, function of pinhole
- ✓ working principle of two-photon microscope: properties of laser source, excitation/emission spectra, penetration ability, advantages
- ✓ superresolution microscopy: principle of STED imaging