

Signal processing

Medical Biophysics I. 10 December, 2025

Miklós Kellermayer

Department of Biophysics and Radiation Biology



SEMMELWEIS
EGYETEM 1769

Medical practice is a series of decisions

The logic of a research scientist and a physician are similar:

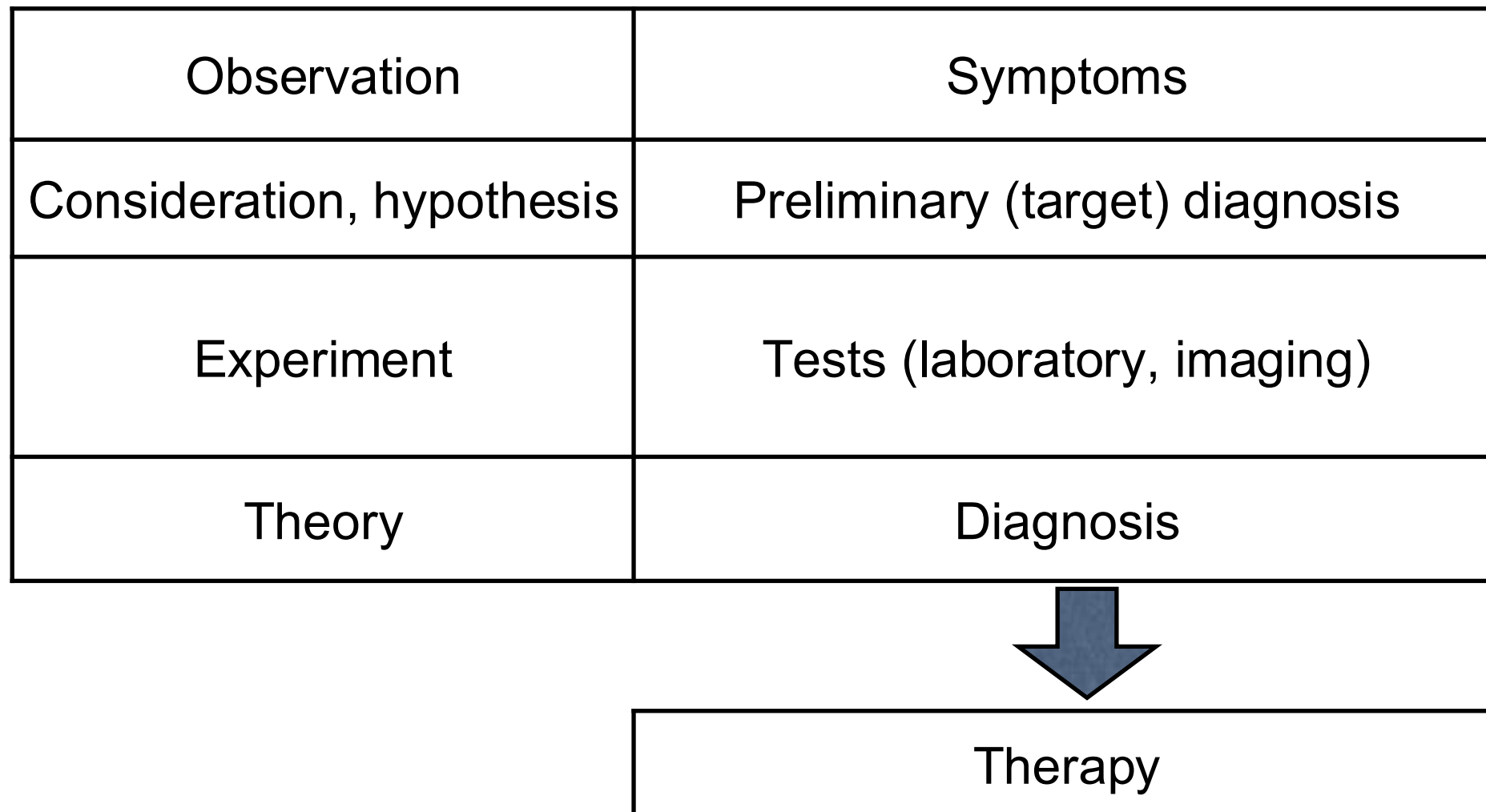

In decision making, **data** are considered:
data collection, evaluation, differentiation

Data are values of stochastic variables

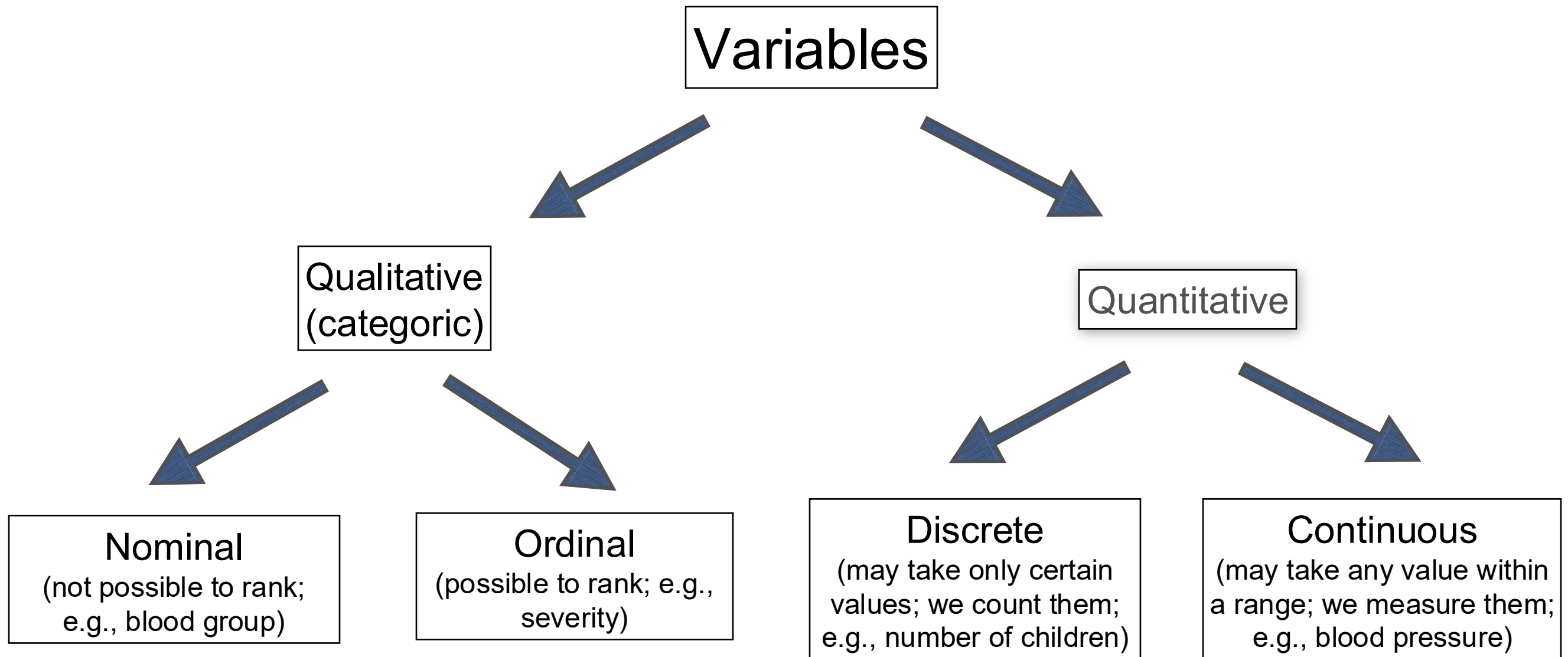

There is random variation in the values of the variable.

A special group of data is the signals from the human body

Signal: (physical) quantity that conveys, transmits or stores **information**

Information: statement that carries message; new knowledge that reduces uncertainty.

Information content of a statistically independent event (e.g., signal):

$$I(p) = \log_2 \left(\frac{1}{p} \right) = -\log_2(p)$$

p : probability of occurrence of the given signal

$I(p)$ unit: **bit** or **sh** (shannon)

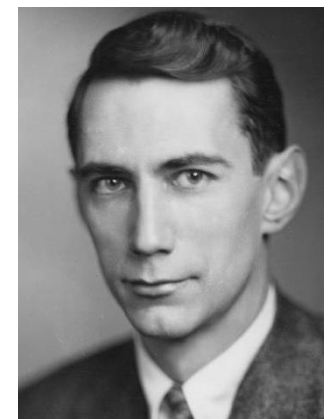

Claude Shannon
(1916-2001)

Classification of signals

static	dynamic (time-dependent)
periodic (quasi periodic)	non-periodic (aperiodikus)
random (stochastic)	deterministic
pulse	continuous
electric	non-electric
analog	digital

periodic, continuous

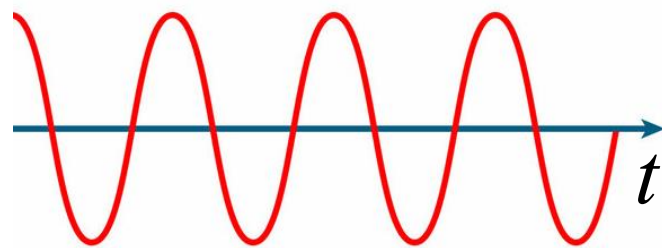

quasi periodic



pulse

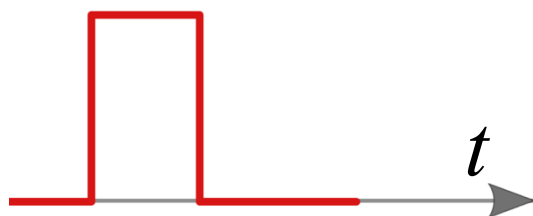

stochastic

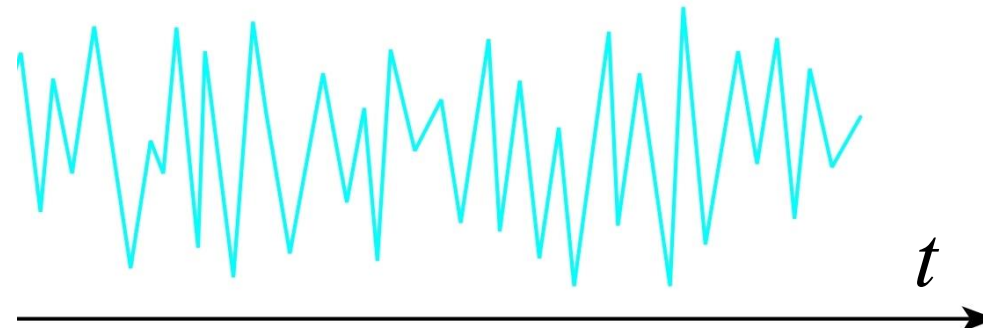

spatially varying signal: image

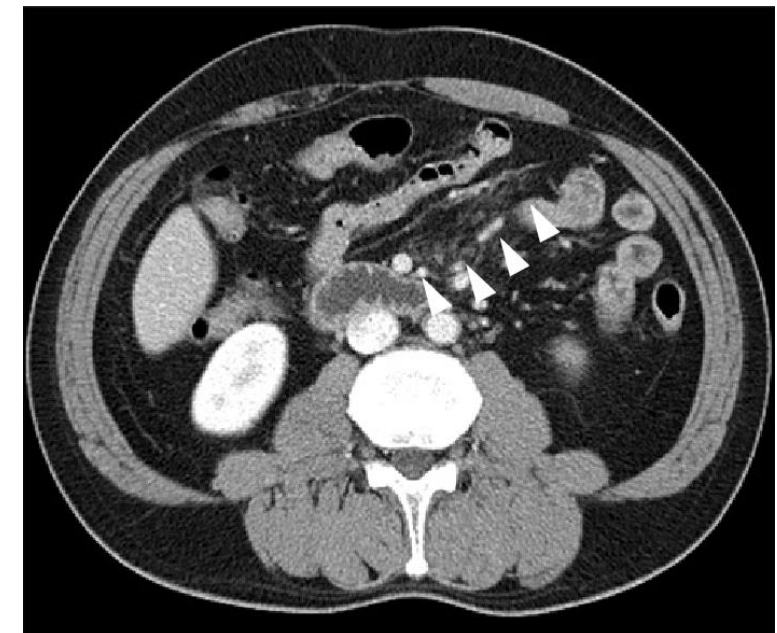

Steps of signal processing

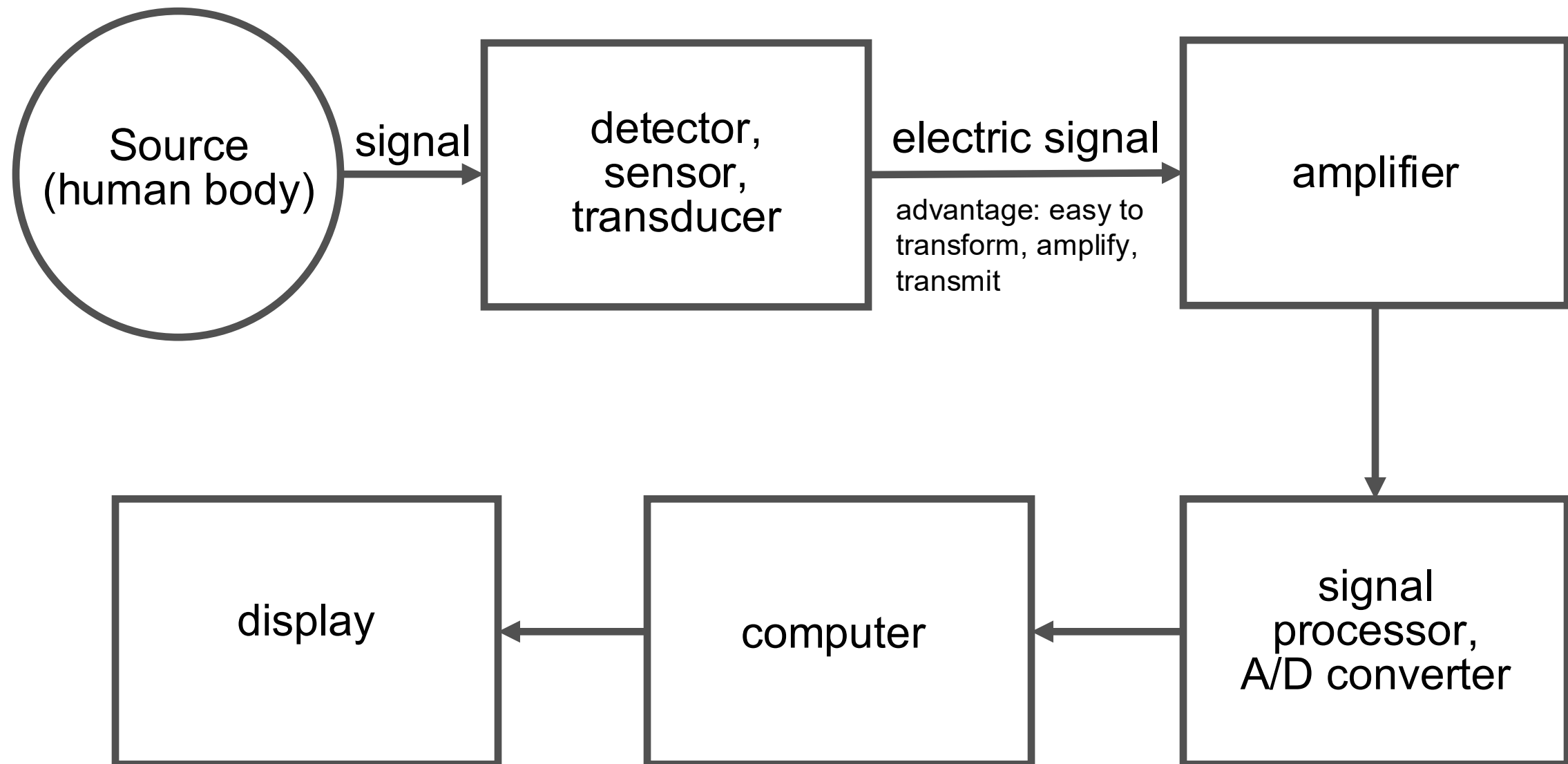

Noise (useless "signal") may arise, to a varying degree, in each step.

Description and comparison of signals

Signal: pulse wave, time-dependent change in arterial pressure

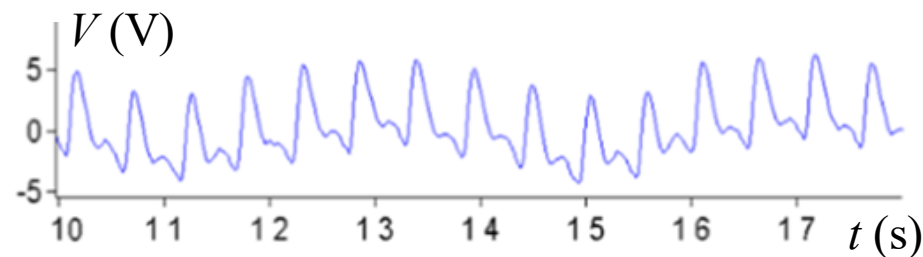

Data: frequency, pulse rate (bpm)

Histogram: frequency/relative frequency organized into classes

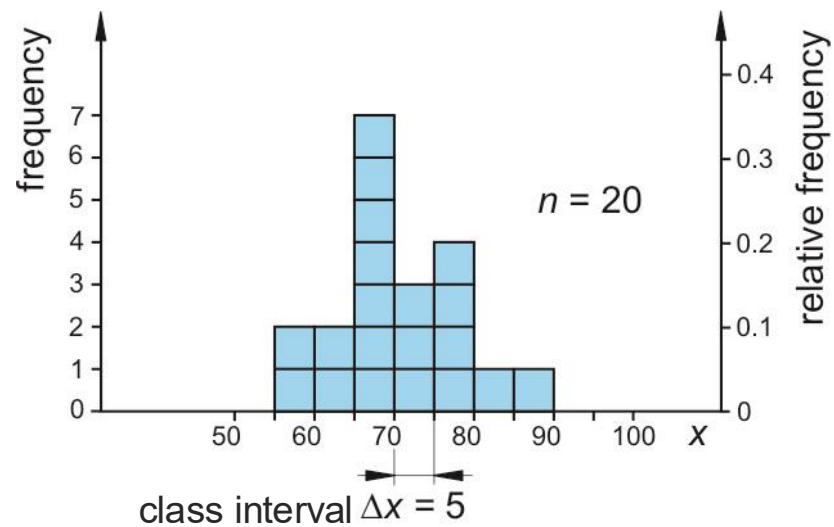

(frequency distribution, density function)

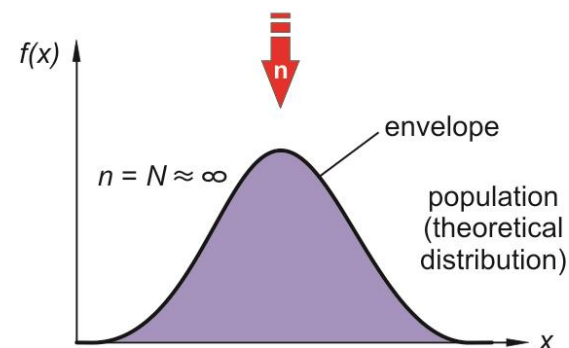
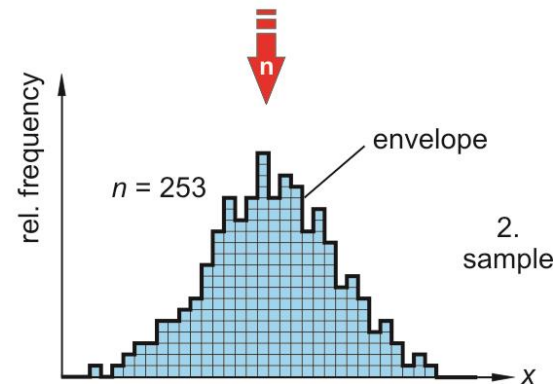
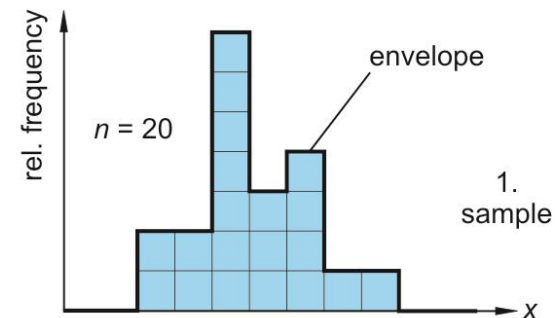

By increasing the sample size (n), we approach the properties of the statistical population.

- Important parameters:
- central measures
 - deviation

Comparison of signal size:
bel scale

$$n = \lg \frac{P_2}{P_1} \text{ B} = \lg \frac{J_2}{J_1} \text{ B} = \lg \frac{E_2}{E_1} \text{ B}$$

power intensity energy

decibel scale $n = 10 \cdot \lg \frac{P_2}{P_1} \text{ dB}$

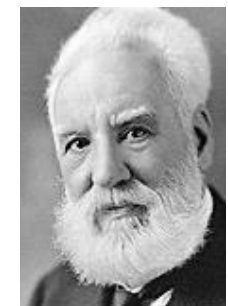

Alexander Graham Bell (1847-1922)

Frequency analysis of signals

Fourier theorem: every function can be expressed as a sum of sines and cosines
(for a periodic function: fundamental frequency + harmonics)

Fourier analysis

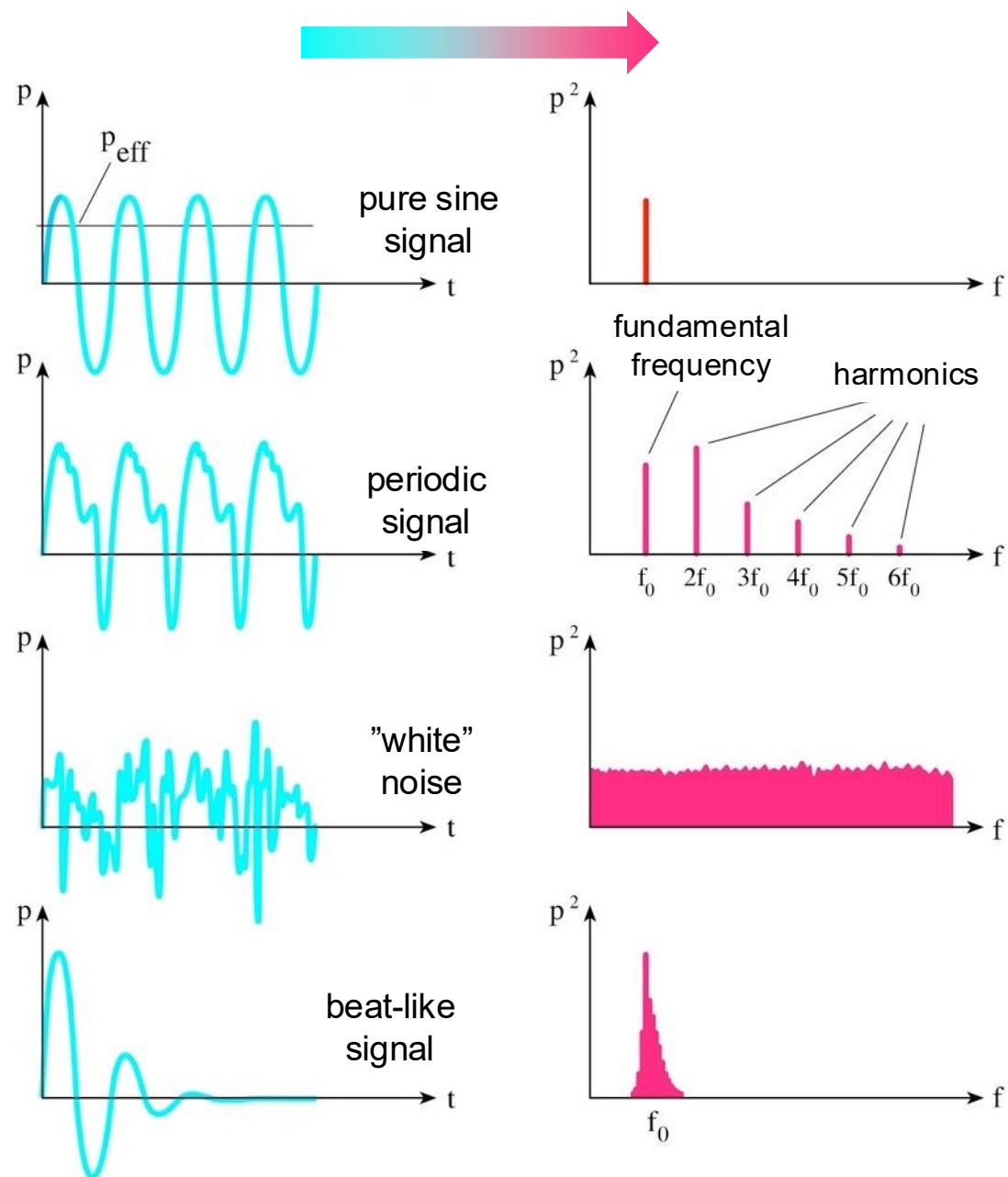

Process of Fourier analysis:



Square wave and its Fourier components:

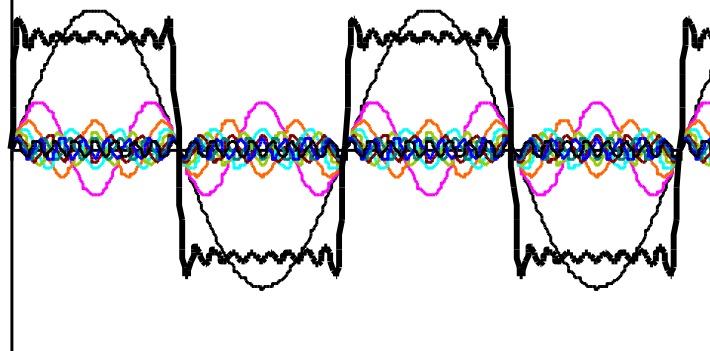

Fourier synthesis

ECG signal synthesis from Fourier components

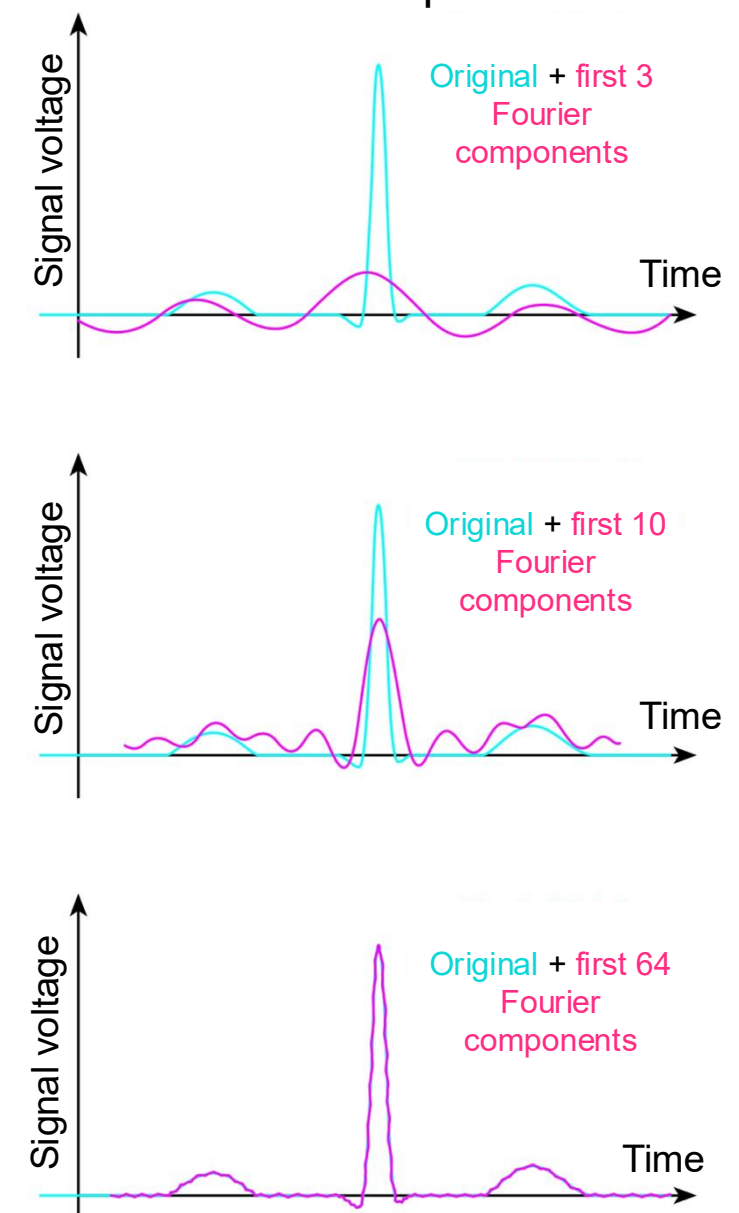

Frequency and amplitude ranges of medically important signals

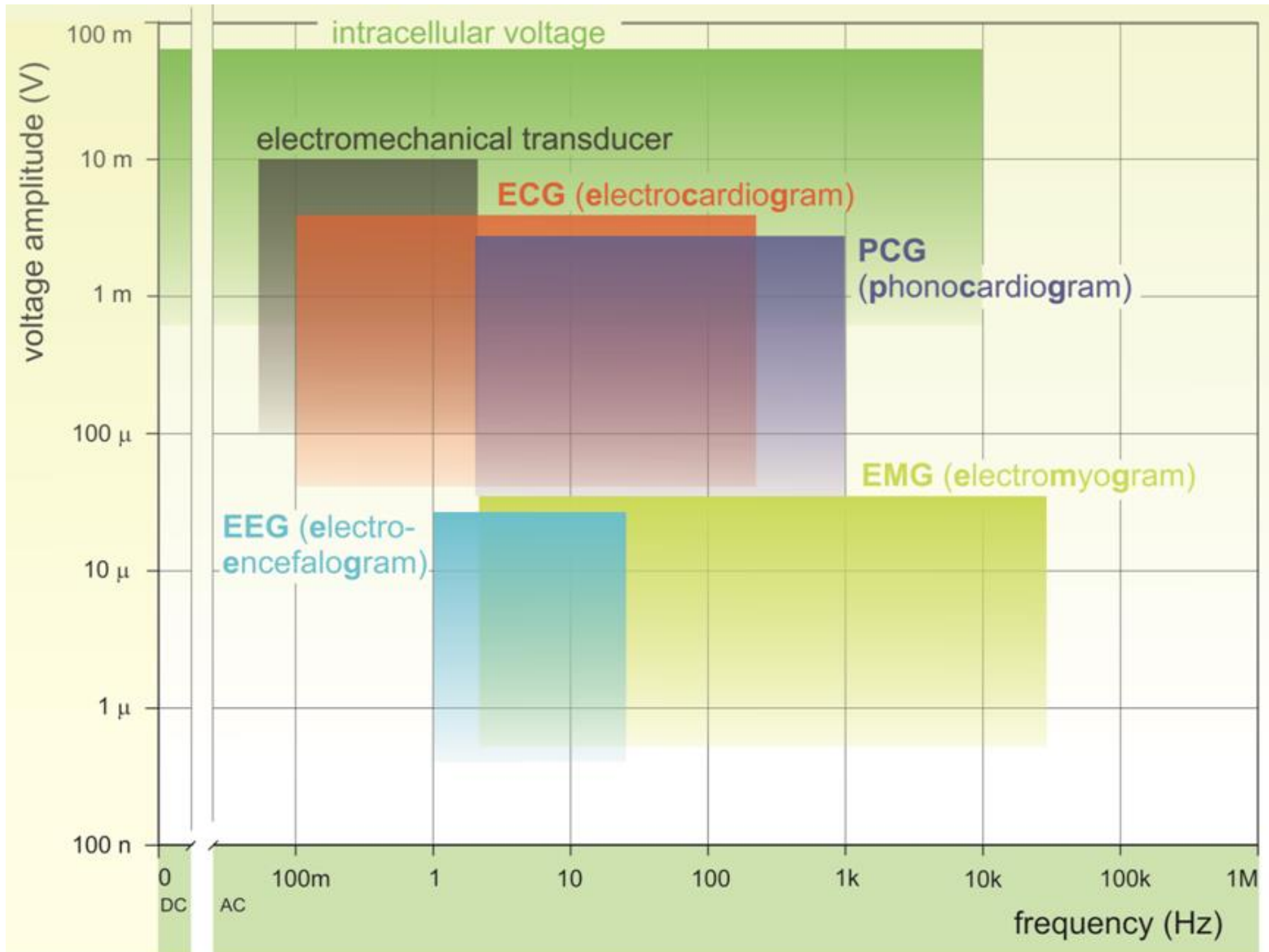

Signal amplification

Amplifier: increases the power of the input signal

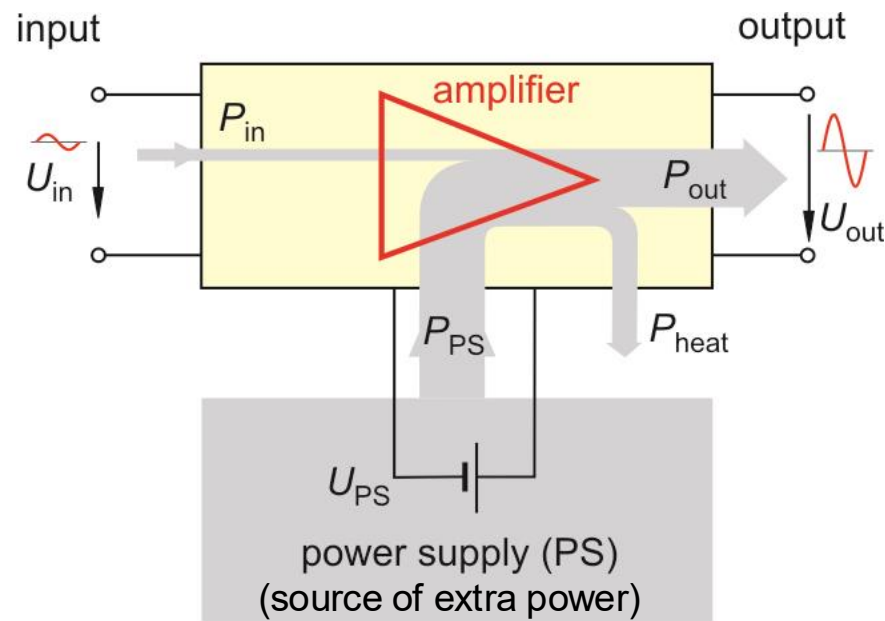

Measures of amplification

Voltage gain

$$A_U = \frac{U_{ki}}{U_{be}}$$

Power gain

$$A_P = \frac{P_{ki}}{P_{be}}$$

Gain level

$$n = 10 \lg A_P = 20 \lg A_U$$

Properties of an amplifier: gain, distortion, transfer bandwidth

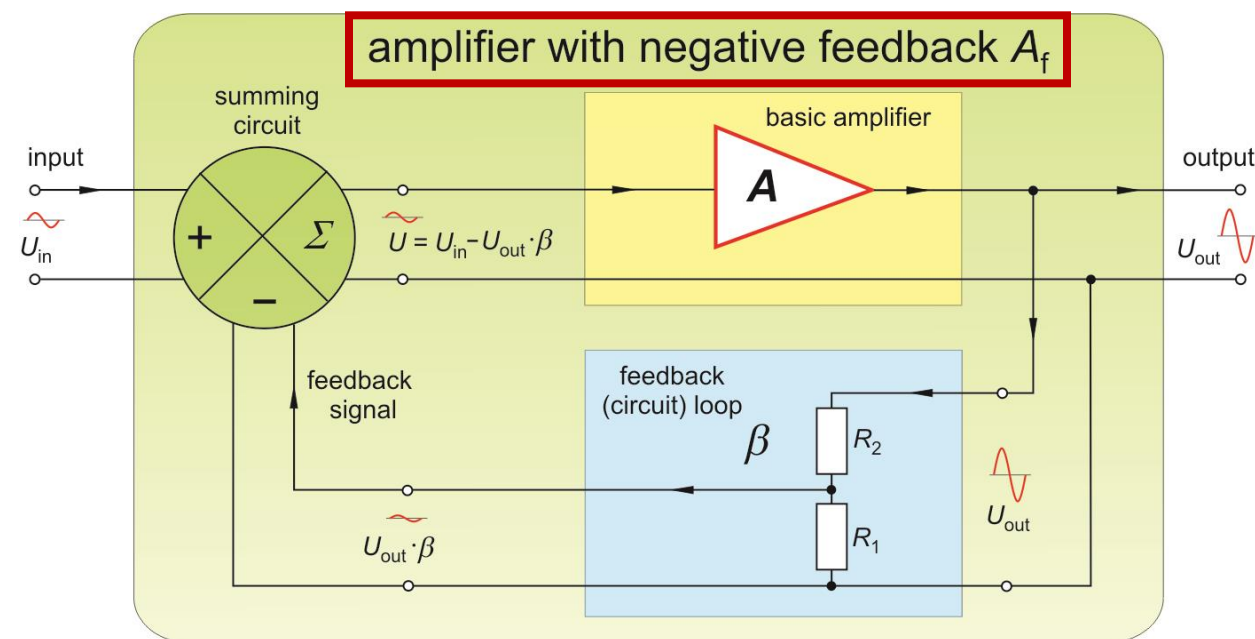

Voltage gain

$$A_f = \frac{A}{1 + \beta A}$$

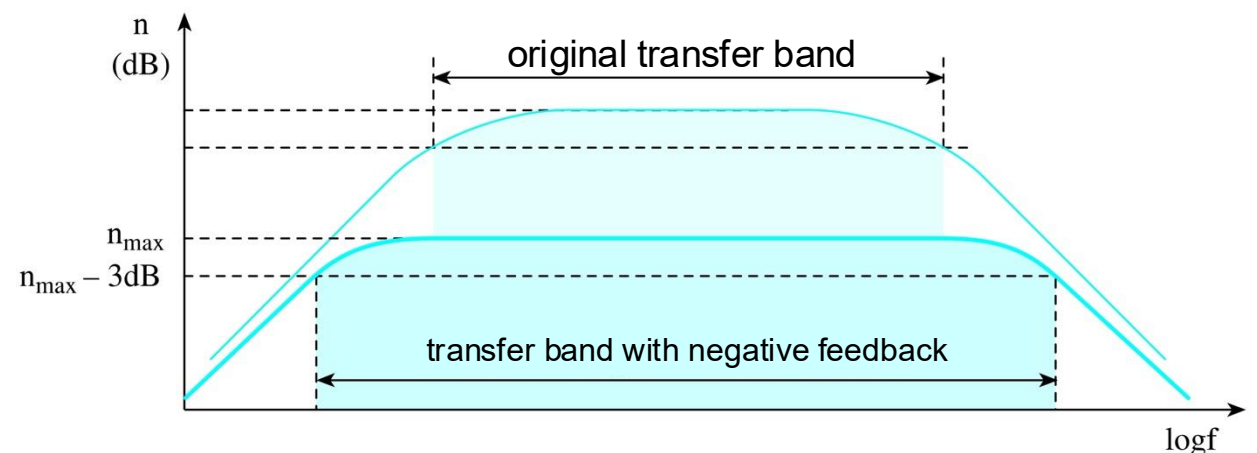

Signal analysis – pulses

Differential discriminator (DD)

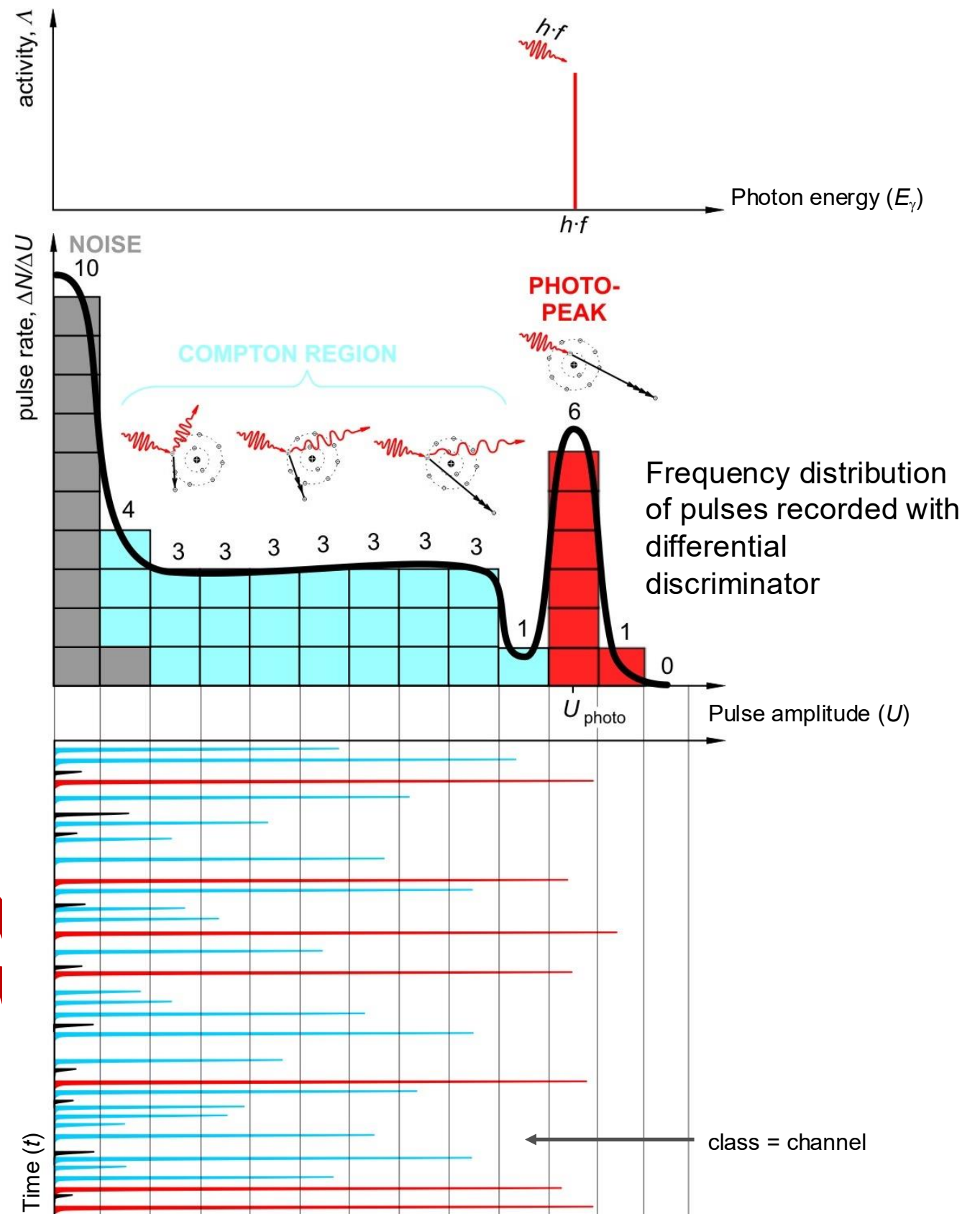
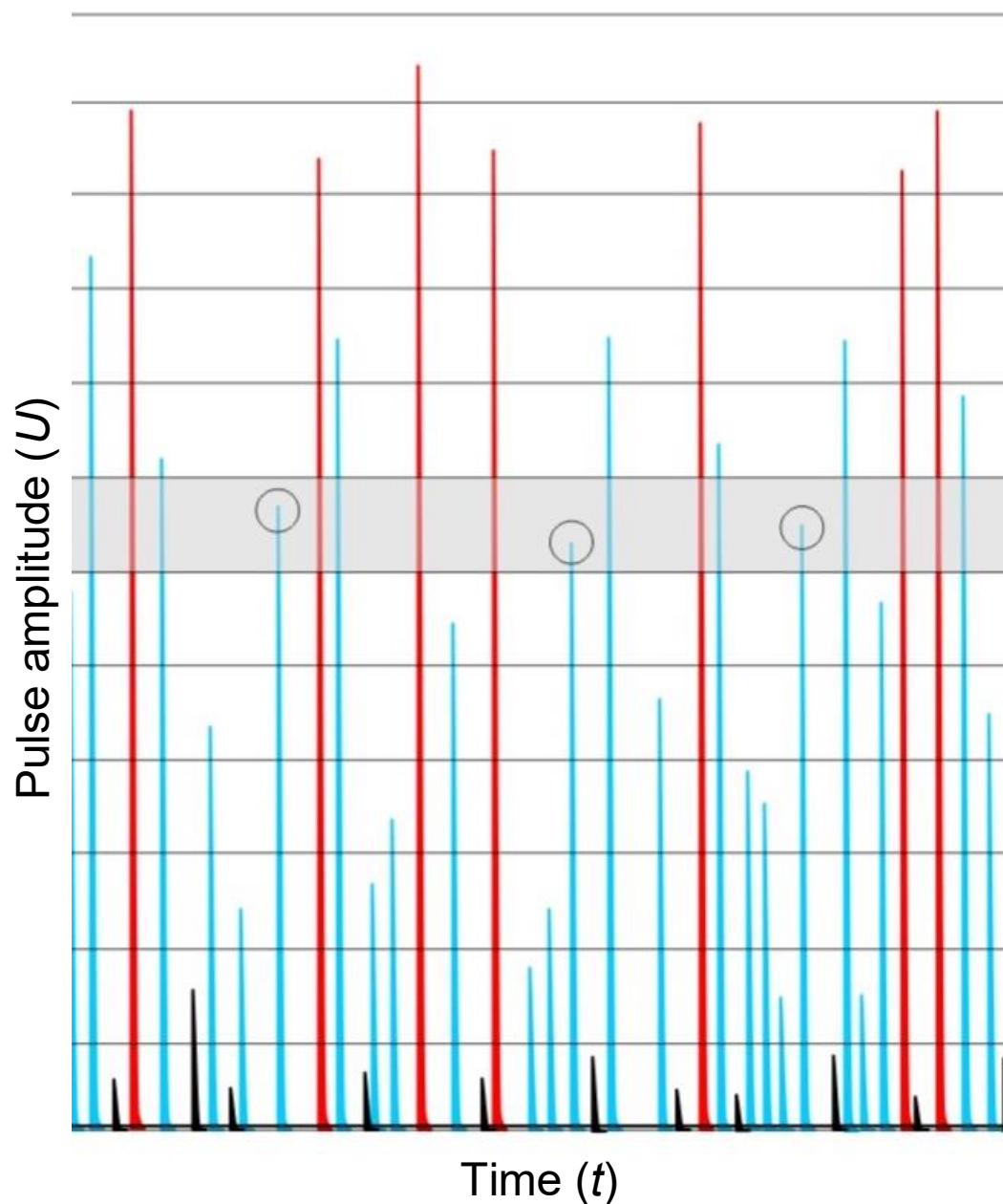

Signal digitization

Advantages of digital signals: easy to store, transmit,
and the problem of noise is reduced

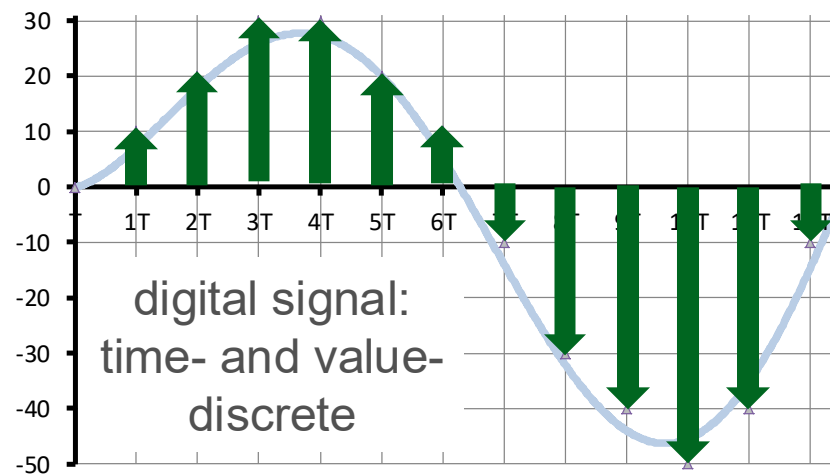
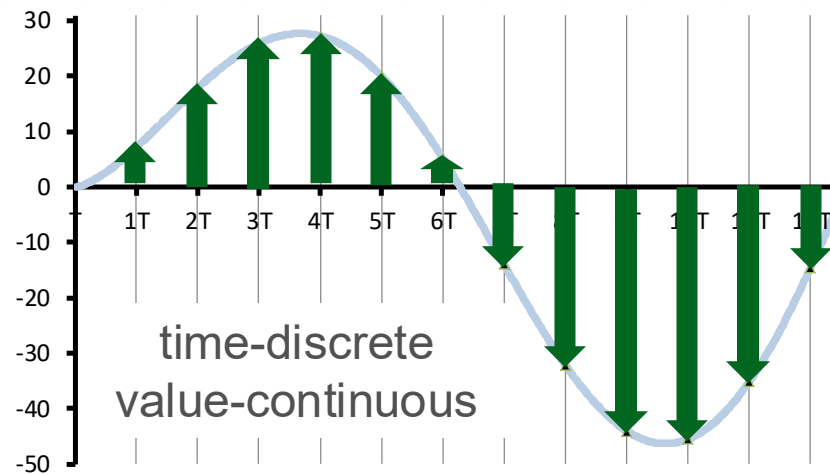
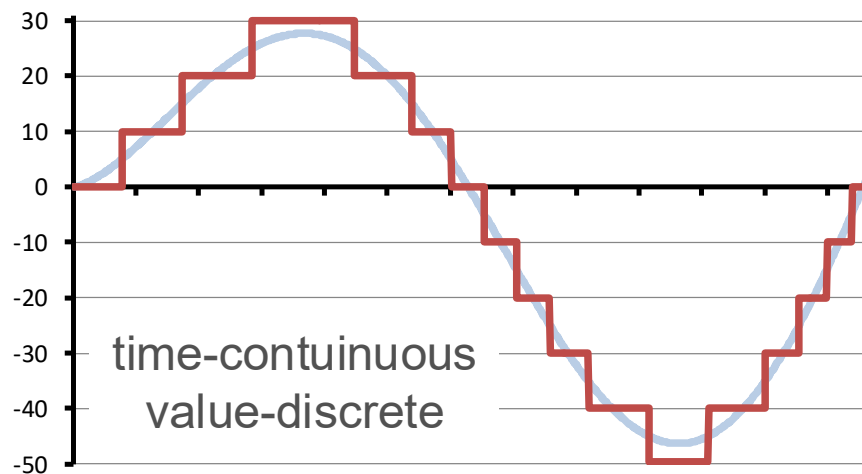
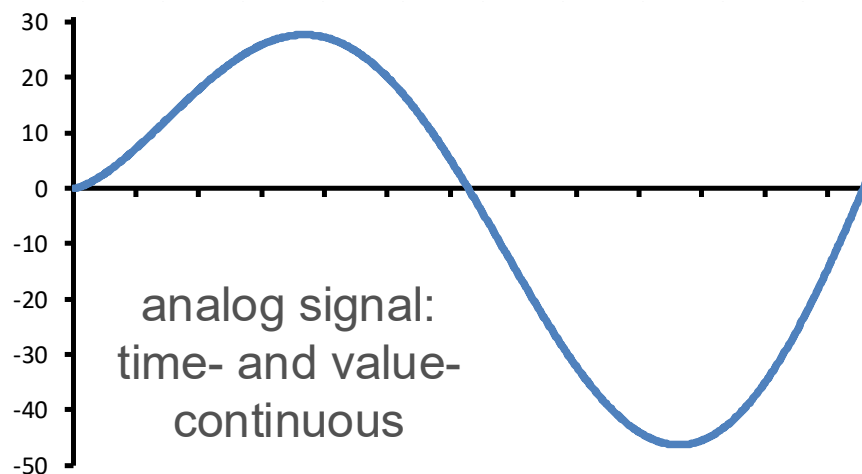

Problem of digitization:

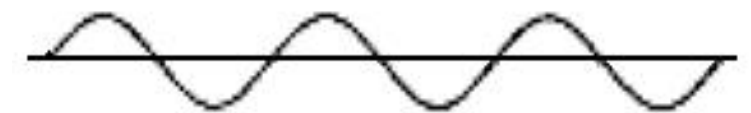

highest-frequency Fourier
component in signal



$f_{\text{sampling}} = f_{\text{max}}$, reconstructed signal:
constant

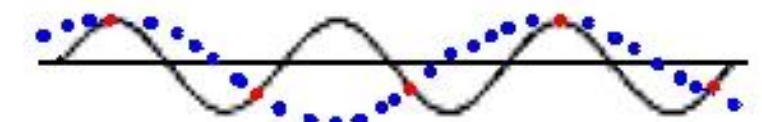

$f_{\text{sampling}} = 1,5 f_{\text{max}}$, reconstructed signal
frequency incorrect

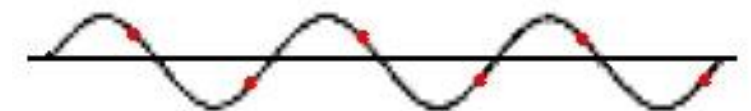

$f_{\text{sampling}} = 2 f_{\text{max}}$, reconstructed
signal frequency correct

Shannon-Nyquist sampling theorem: the minimal sampling frequency
must be twice that of the highest harmonic of the signal.

Noise reduction I.

Averaging

Integral discriminator

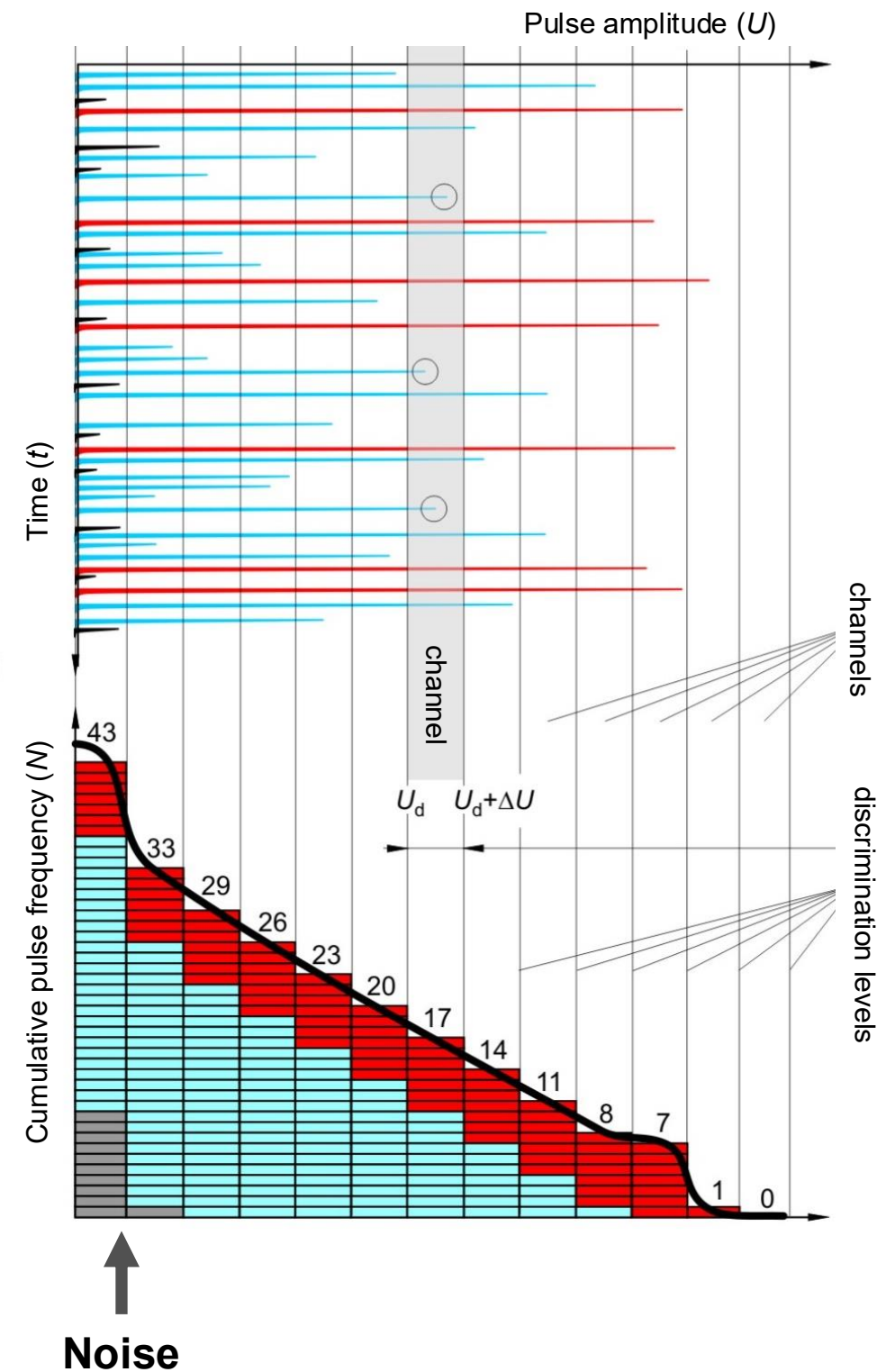
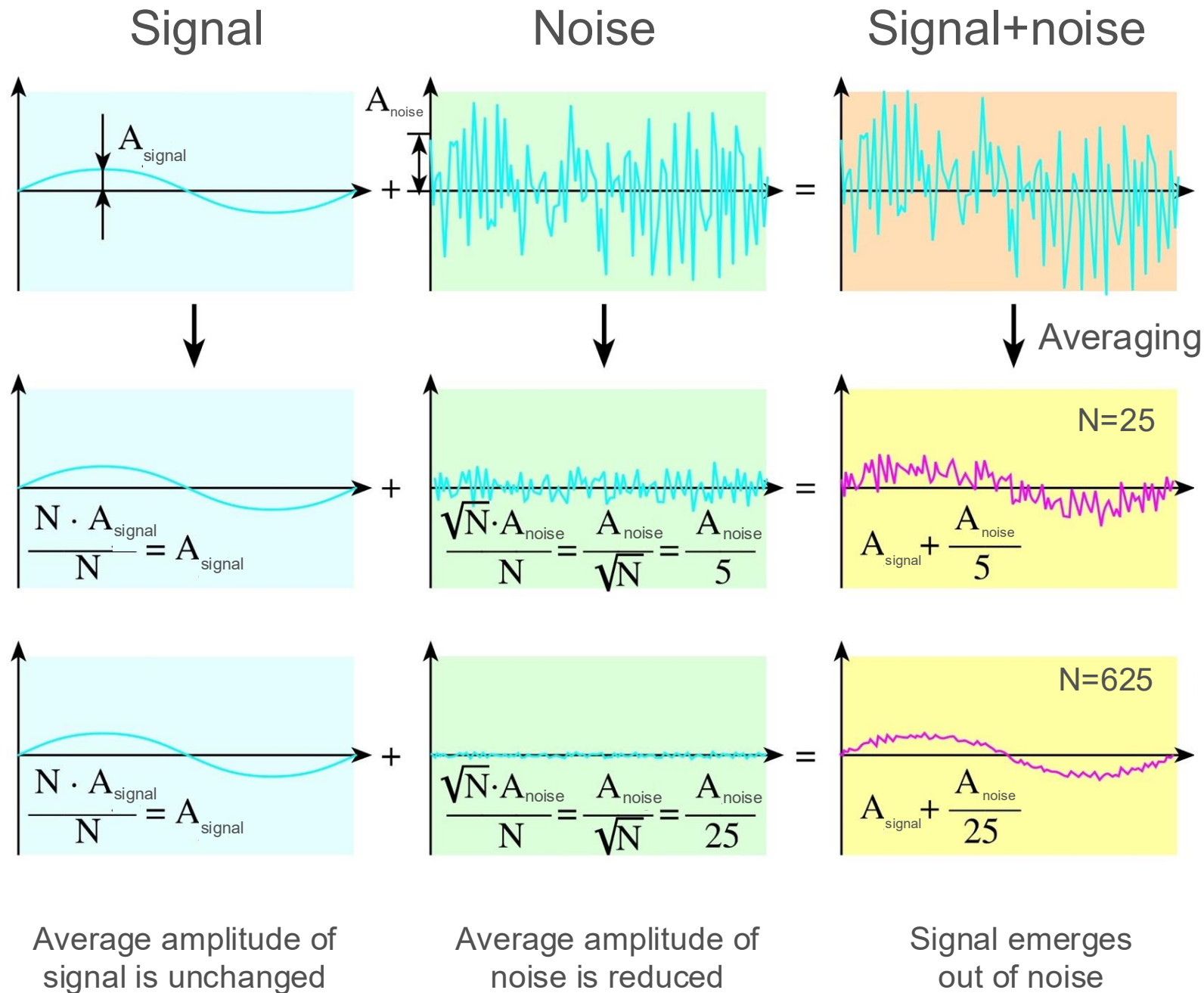

Noise reduction II.

Frequency selective signal transfer/amplification

Voltage divider

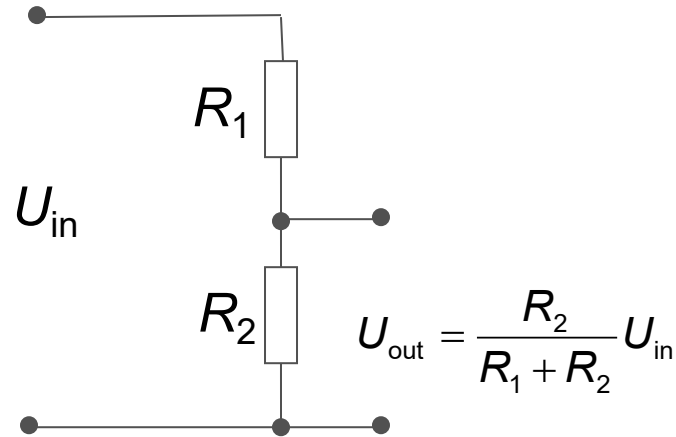

Distorsion-free,
frequency-
independent signal
transfer

High-pass filter

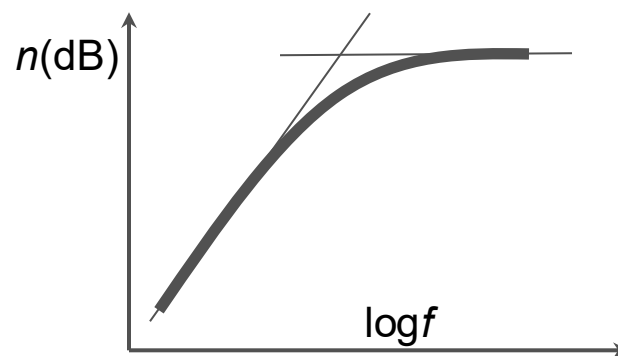
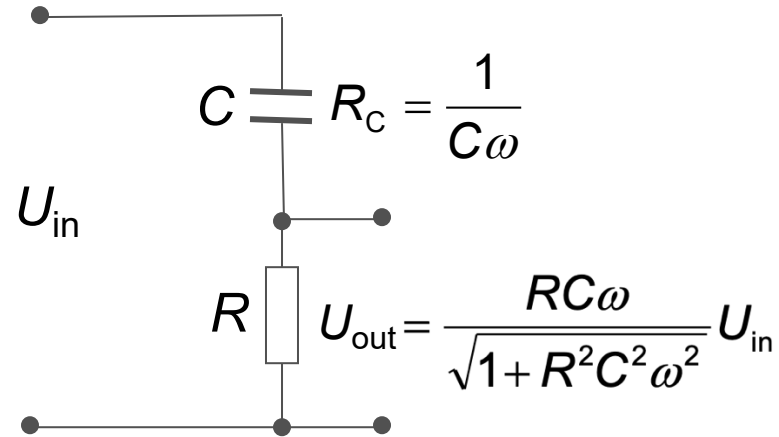

Low-pass filter

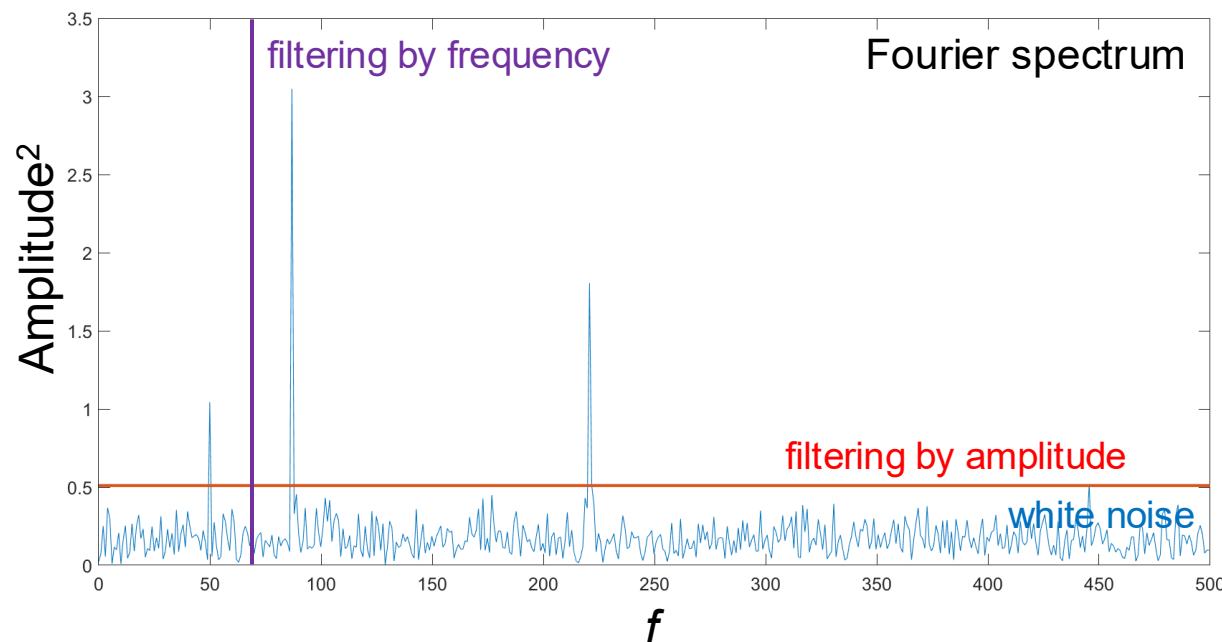
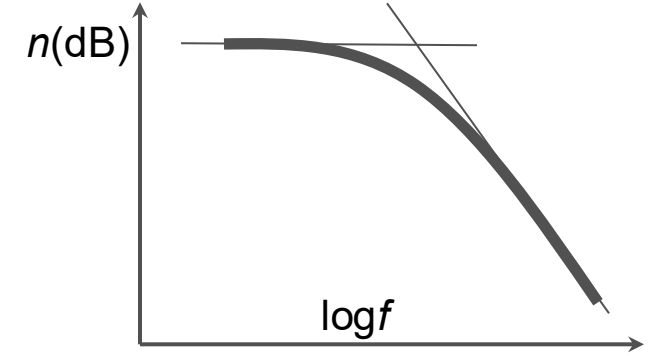
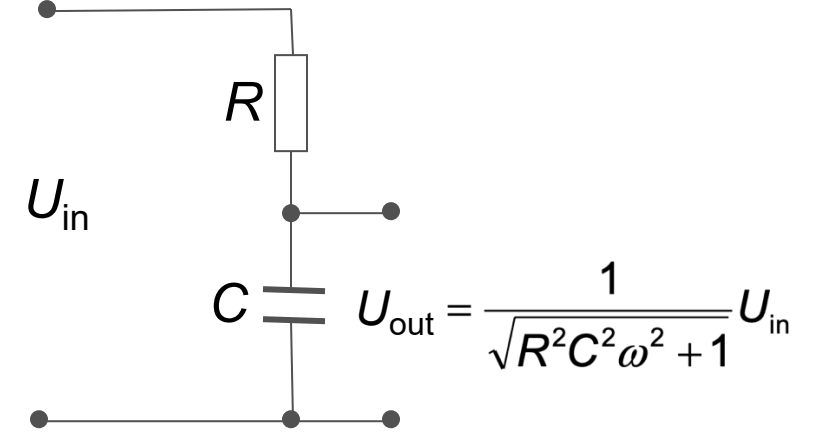

**Noise reduction
based on Fourier
analysis**

**Active noise
canceling**

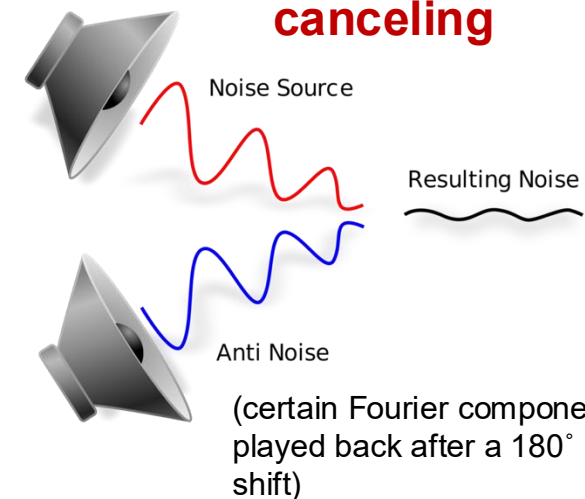

Cloud-based storage, transfer and processing of medical signals: telemedicine

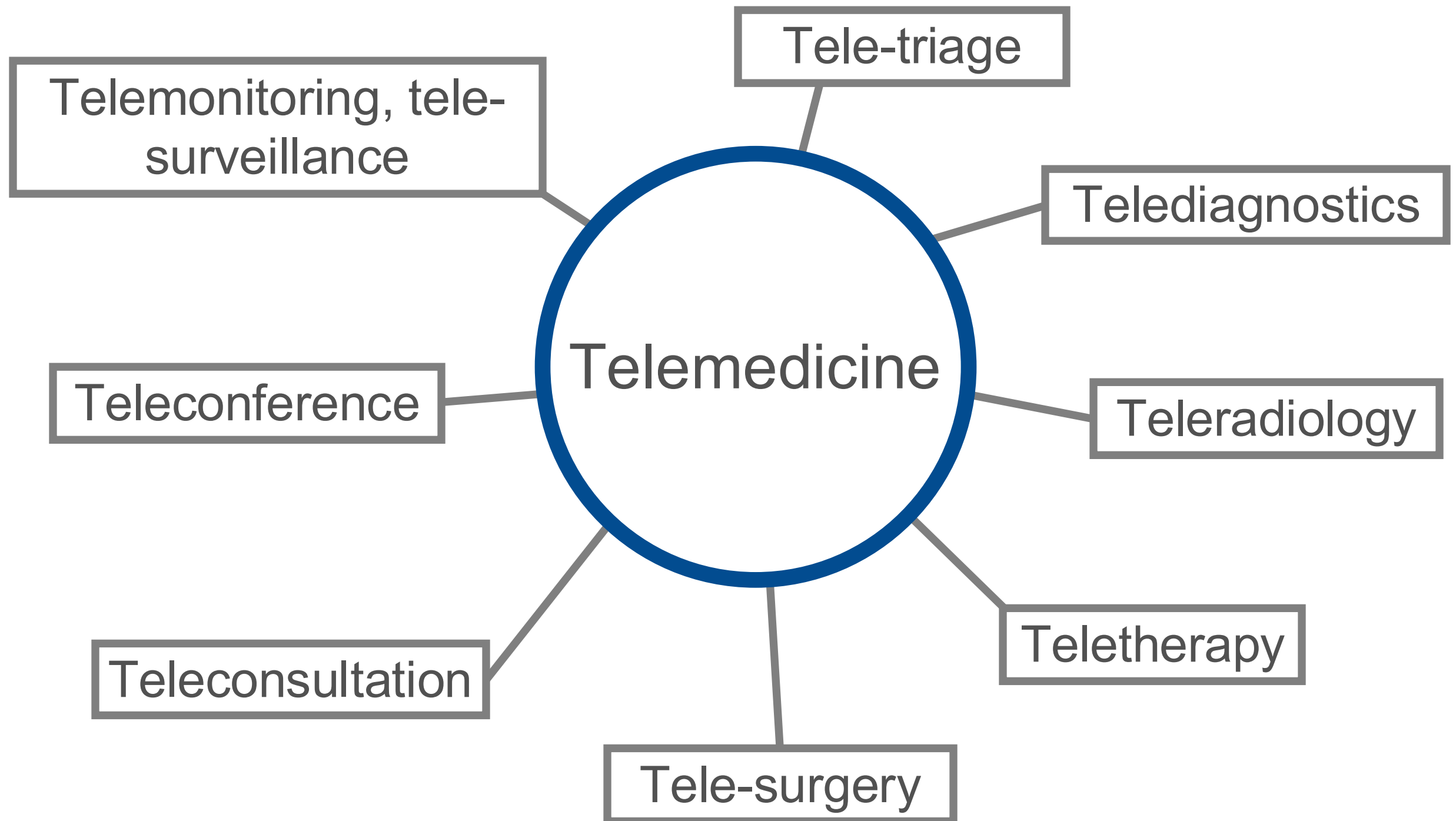

Feedback



<https://feedback.semmelweis.hu/feedback/index.php?feedback-qr=995QH295K2DY5DEG>