

Methoden der Strukturenuntersuchung

Elektronmikroskope

Diffraktionsmethode

CD-Spektroskopie

Gusztáv Schay



SEMMELWEIS
UNIVERSITY 1769

ELEKTRONENMIKROSKOPE

$$\lambda = \frac{h}{mv}$$

Transmissionselektronenmikroskop

Rasterelektronenmikroskop

Materienwellen!

Transmissionselektronenmikroskop

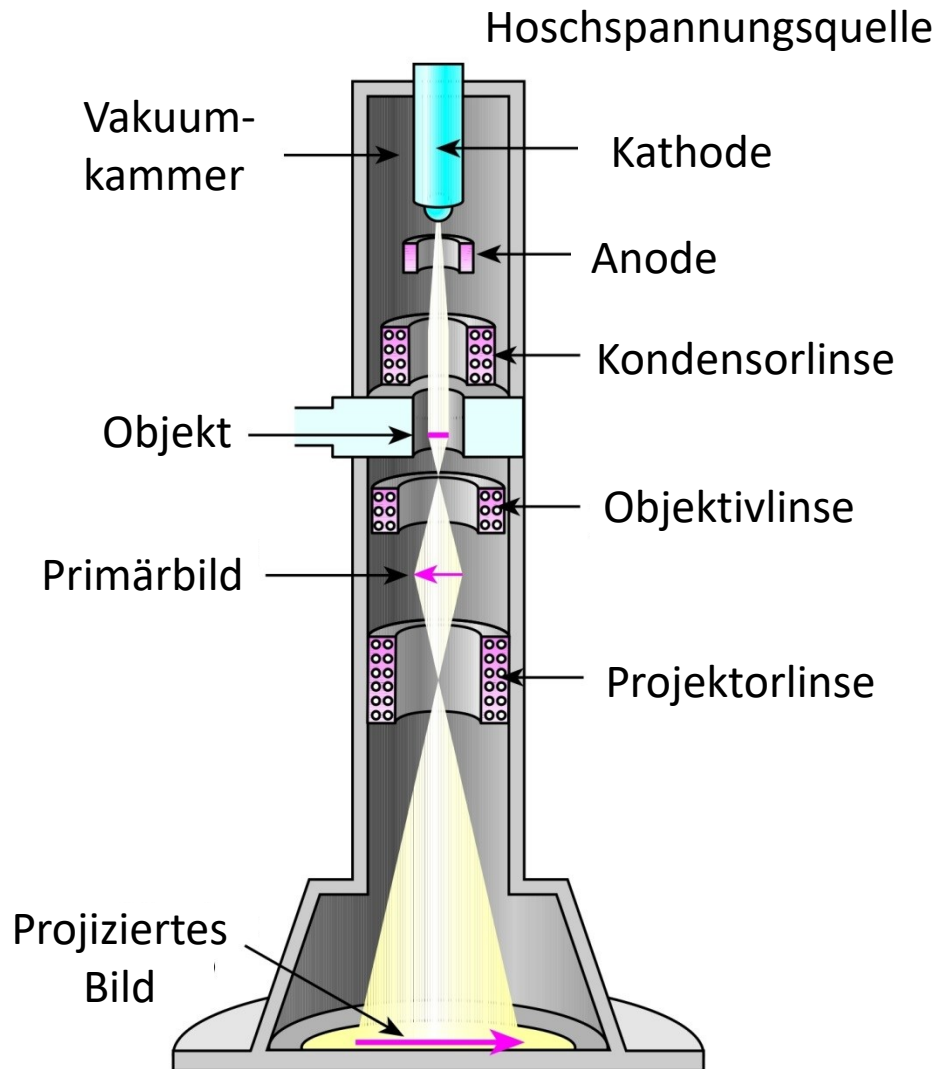

Rasterelektronenmikroskop

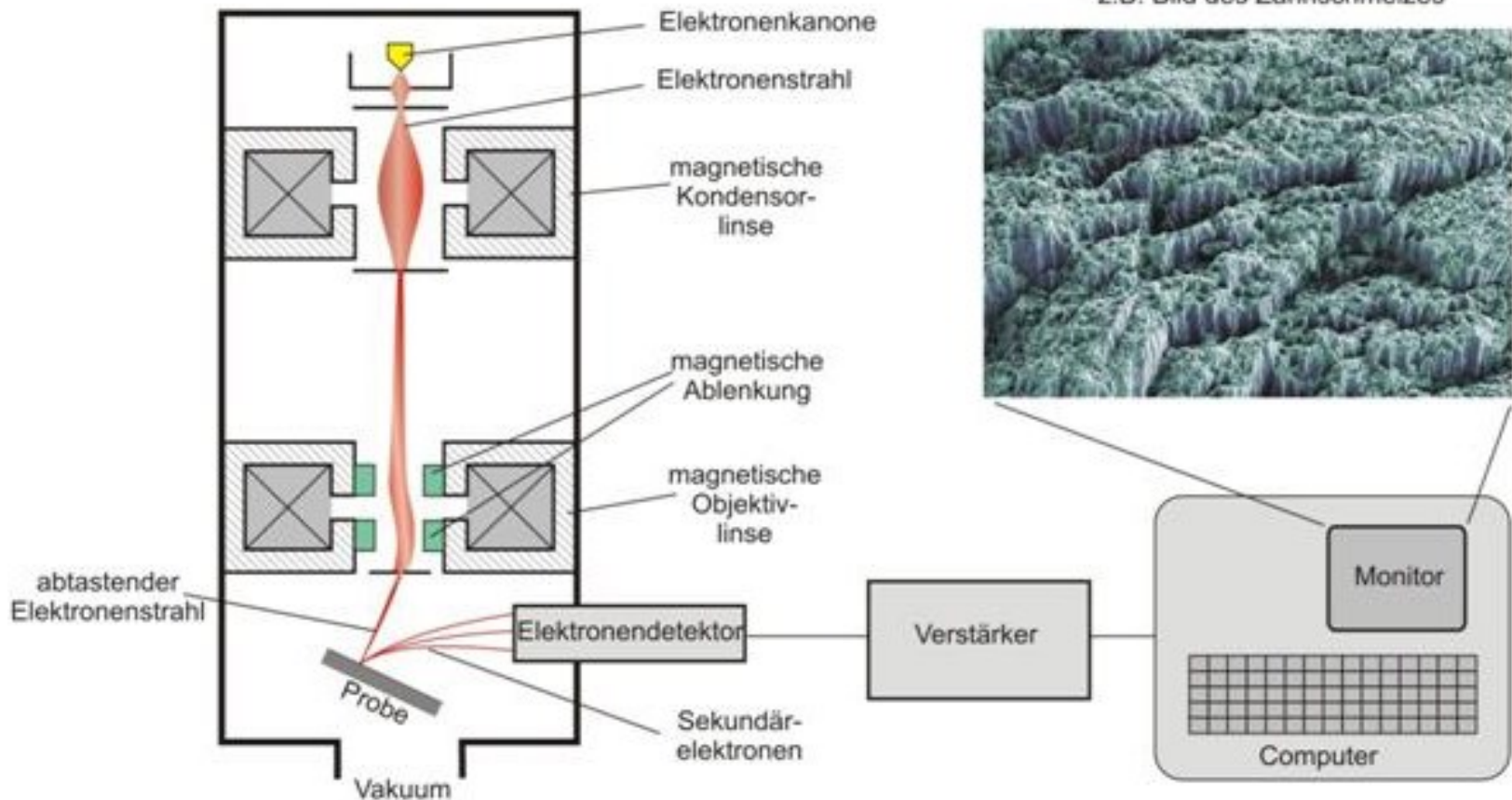

Auflösungsvermögen des Elektronenmikroskops

Abbe'sches Prinzip und Materialwellen

Materialwelle: Zu einem Teilchen mit m Masse und v Geschwindigkeit, kann man eine Welle (Materienwelle)

zuordnen, die eine Wellenlänge von $\lambda = \frac{h}{mv}$ hat.

Die Geschwindigkeit des Elektrons nach einer Beschleunigung mit U Spannung beträgt:

$$v = \sqrt{\frac{2eU}{m}} \quad \text{womit:} \quad \lambda = \frac{h}{\sqrt{2emU}}$$

Typisch kann λ 5 pm sein. Aber ω ist sehr klein! $NA \approx 0,002$

$$\delta = 0,61 \cdot \lambda / (n \cdot \sin\omega) \approx \text{nm}$$

DIFFRAKTIONSMETHODE

Röntgendiffraktion

Anwendung der Röntgenstrahlung in Strukturanalyse der Materie.

Zur Erinnerung:
Diffraktion des Lichtes

$$\sin \alpha_k = \frac{k\lambda}{d}$$

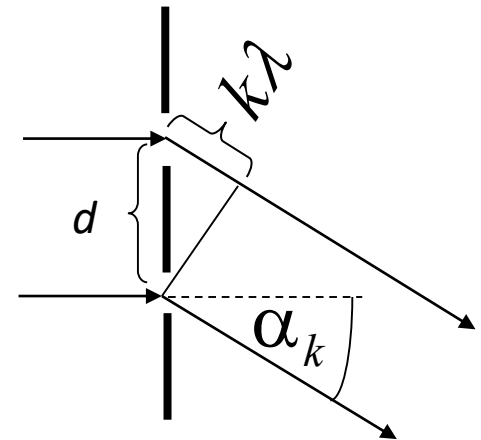

Röntgendiffraktion

Was für ein Gitter passt zur Röntgenstrahlung?

$$\lambda < d$$

$$\lambda_{\text{Rtg}} \approx 10\text{-}100 \text{ pm}$$

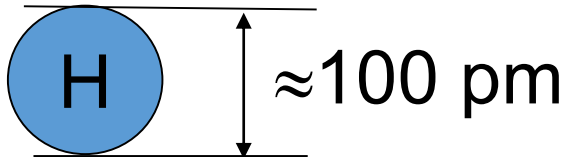

$\approx 100 \text{ pm}$

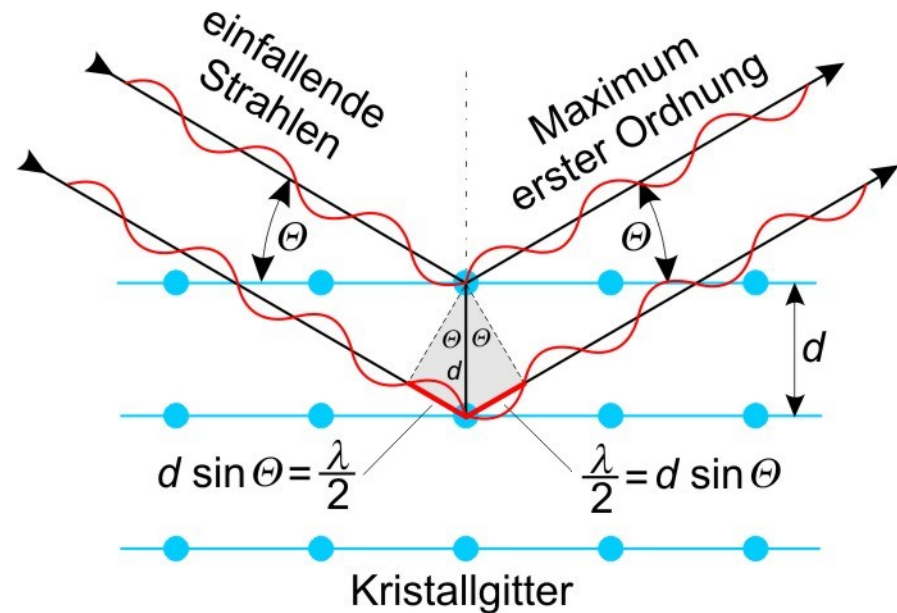
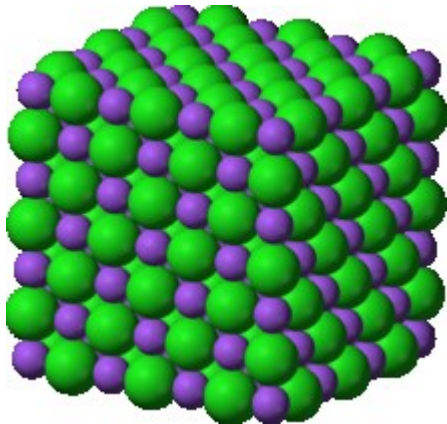

Kristall \rightarrow auch DNS $n\lambda = 2d \sin \theta$!!!

Aufbau des Röntgendiffraktionsgerätes

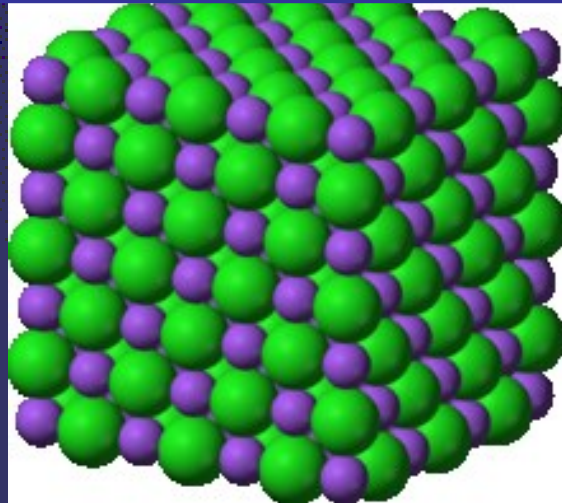

Röntgenröhre



10-40 kV

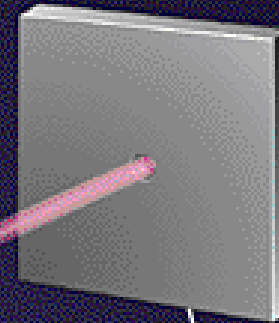

PB Kollimator

Kristall

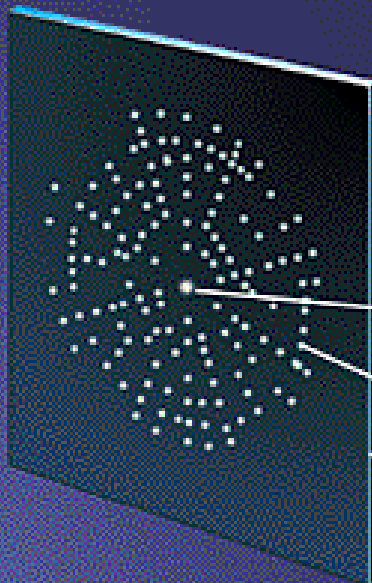

Nicht gebeugte Strahlung (0-te Ordnung)

Gebeugte Strahlen

Photoplatte

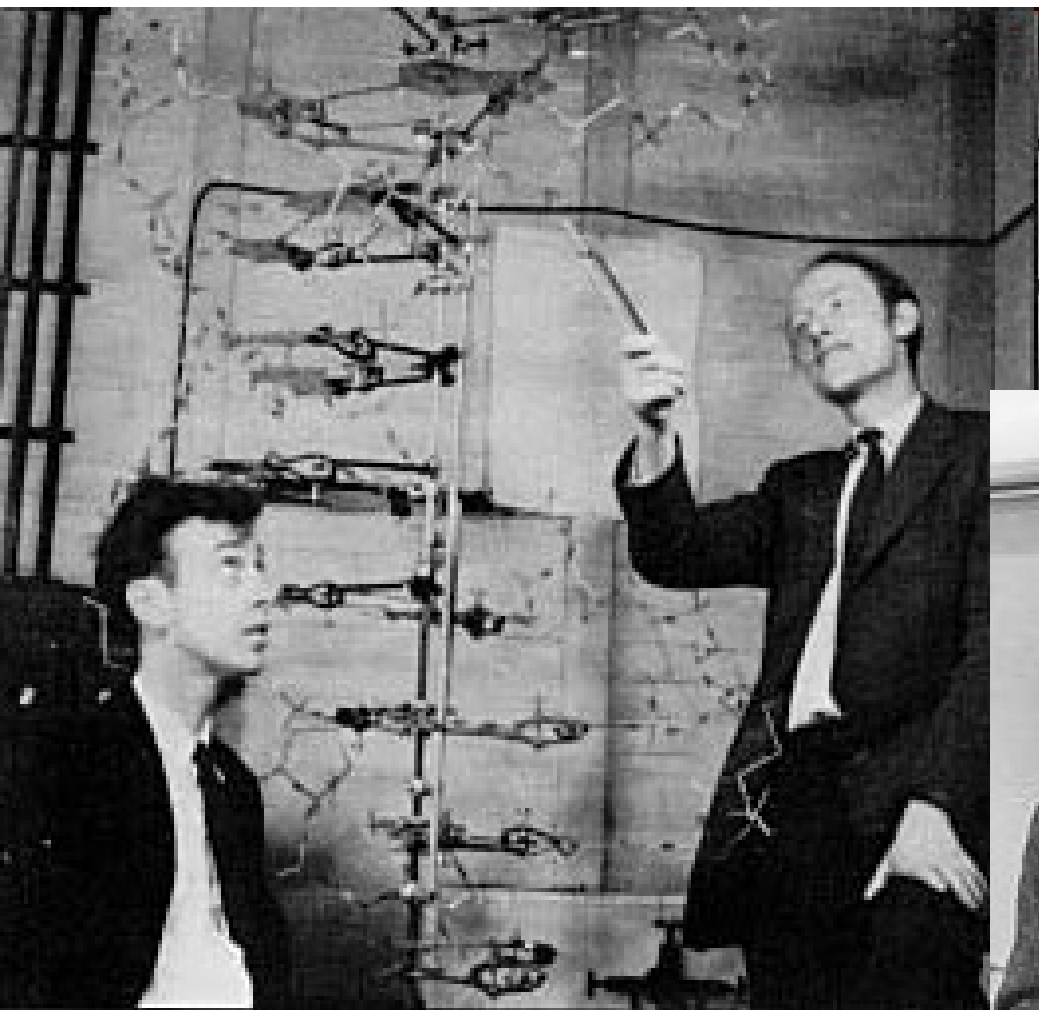

Eiweißkristalle

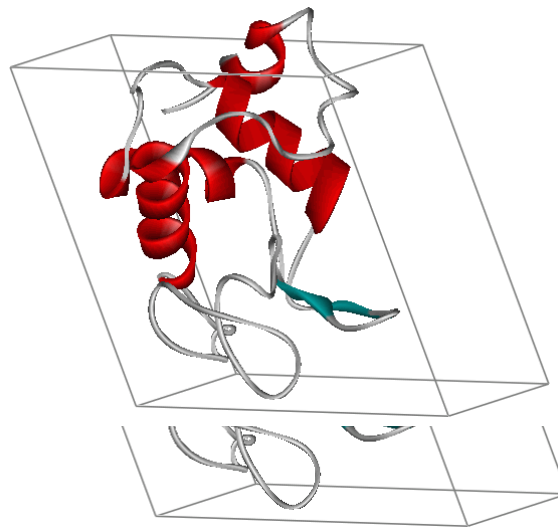

Bestimmung der Raumstruktur der Eiweiße



Lysozyme

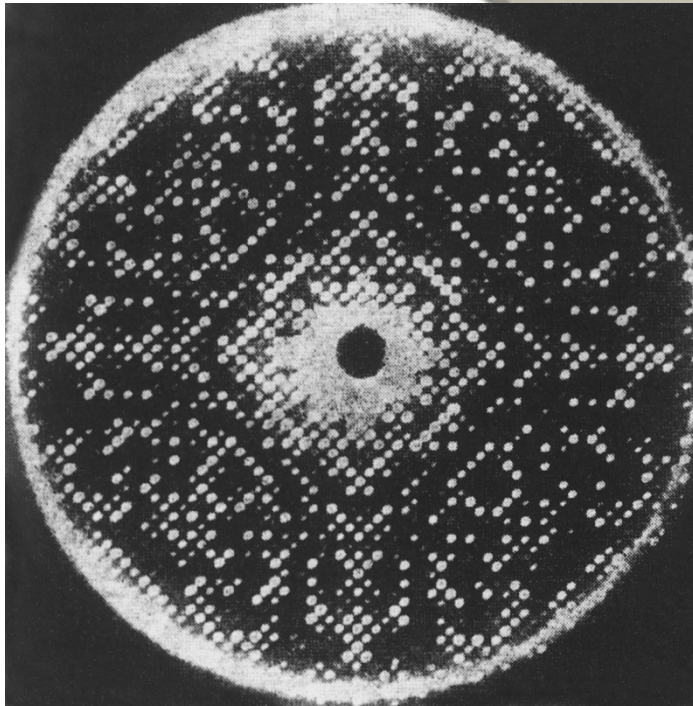

- Welcome
- Deposit
- Search
- Visualize
- Analyze
- Download
- Learn

A Structural View of Biology

This resource is powered by the Protein Data Bank archive-information about the 3D shapes of proteins, nucleic acids, and complex assemblies that helps students and researchers understand all aspects of biomedicine and agriculture, from protein synthesis to health and disease.

As a member of the wwPDB, the RCSB PDB curates and annotates PDB data.

The RCSB PDB builds upon the data by creating tools and resources for research and education in molecular biology, structural biology, computational biology, and beyond.

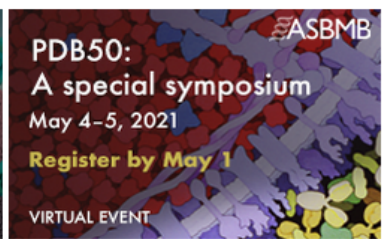

May Molecule of the Month

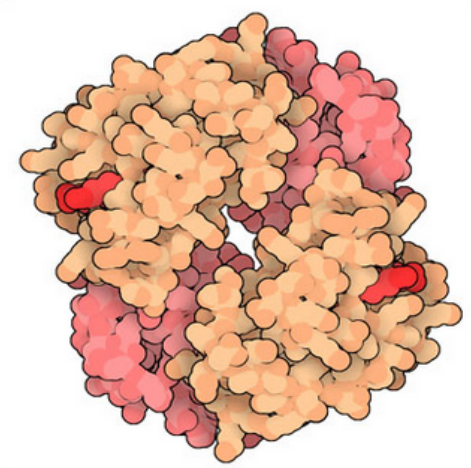

Fetal Hemoglobin

Latest Entries As of Tue Apr 27 2021

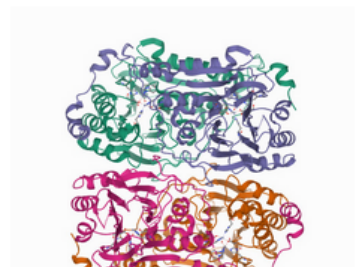

Features & Highlights

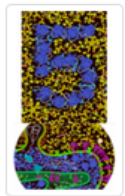

EXTENDED: Enter the 2021 CellPAINT Contest by May 6 Create images inspired by vaccines and by 50 years of the PDB with CellPAINT and win prizes

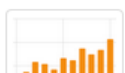

Future Planning: Entries with extended PDB and CCD ID codes will be distributed in PDBx/mmCIF format

News Publications



Explore the History of the PDB Explore PDB's historical highlights alongside milestone advances in structural biology » 04/27/2021



Annual Report Published Download the 2020 Annual Report for an overview of recent RCSB PDB activities, PDB structures and the

Elektronen und Neutronendiffraktion

λ : Materialwellen

Elektronen: Kleine Eindringtiefe: Oberflächen

Elektronen und Neutronen werden an den Atomkernen gestreut.

(Rtg wird durch Elektronenwolken gestreut.)

Elektronen werden an den schwereren Kernen gestreut

Neutronen auch an den Protonen, =>

Neutronendiffraktion gut zur Strukturuntersuchung von wasserstoffhaltigem Material.

In der Praxis brauchen wir einige Å Wellenlängen um Kristallstrukturen zu untersuchen

$$E = \frac{p^2}{2m} \quad \lambda = \frac{h}{p}$$

$$\lambda [\text{nm}] \approx \frac{0.9045}{\sqrt{E [\text{meV}]} \quad \text{or} \quad E [\text{meV}] \approx 0.8181/\lambda [\text{nm}]^2$$

Dazu müssen die Neutronen verlangsamt werden : Neutronenmoderatoren werden gebraucht.

Moderator	Example	Temperature (K)	Neutron energies (meV)	Wavelengths (nm)
Hot source	Graphite C	2300	100–1000	0.03–0.09
Thermal source	Water H ₂ O	300	5–100	0.09–0.4
Cold source	Liquid D ₂	25	0.05–5	0.4–4

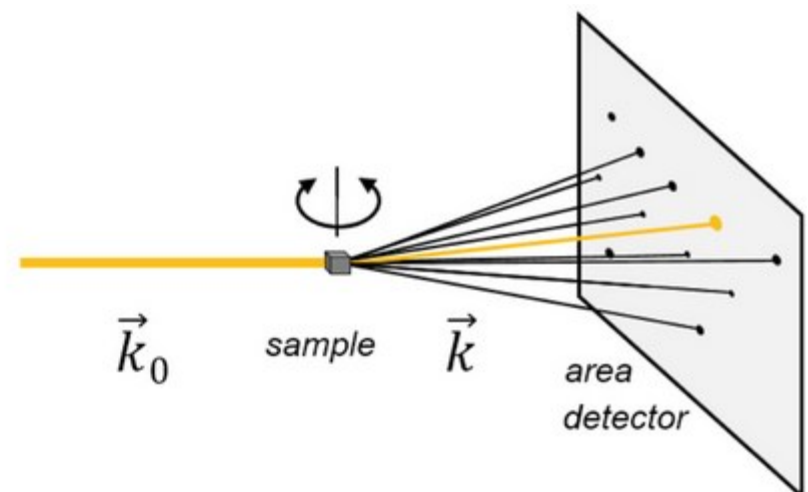
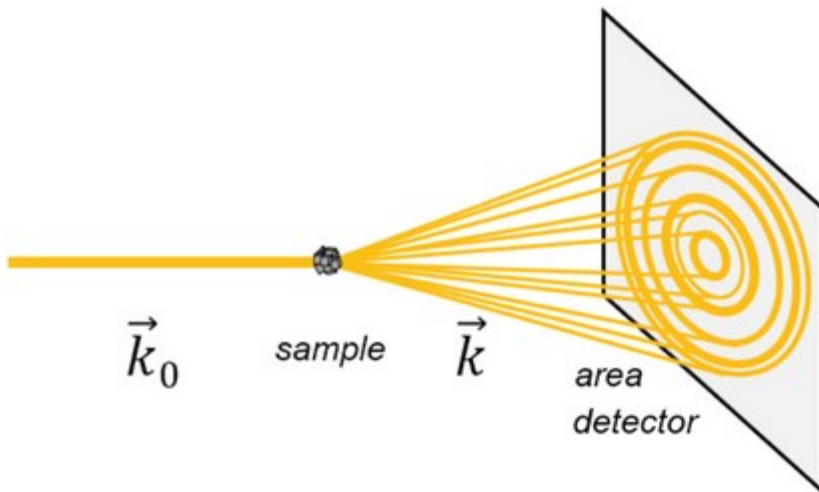

CD

Circular dichroism spectroscopy

Elektro (**E**) magnetische (**B**) Welle = Licht

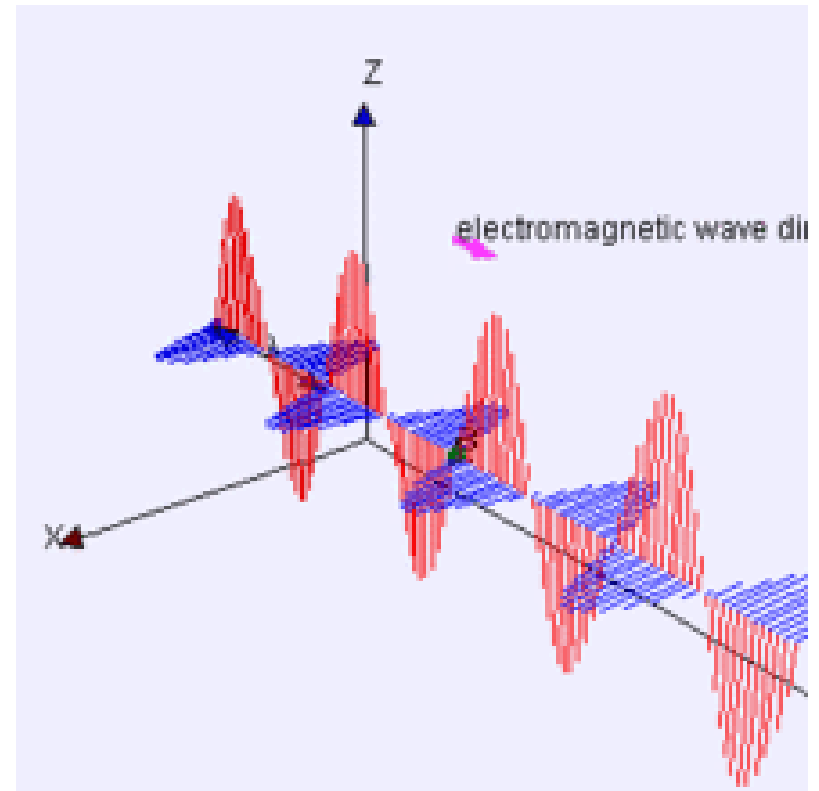
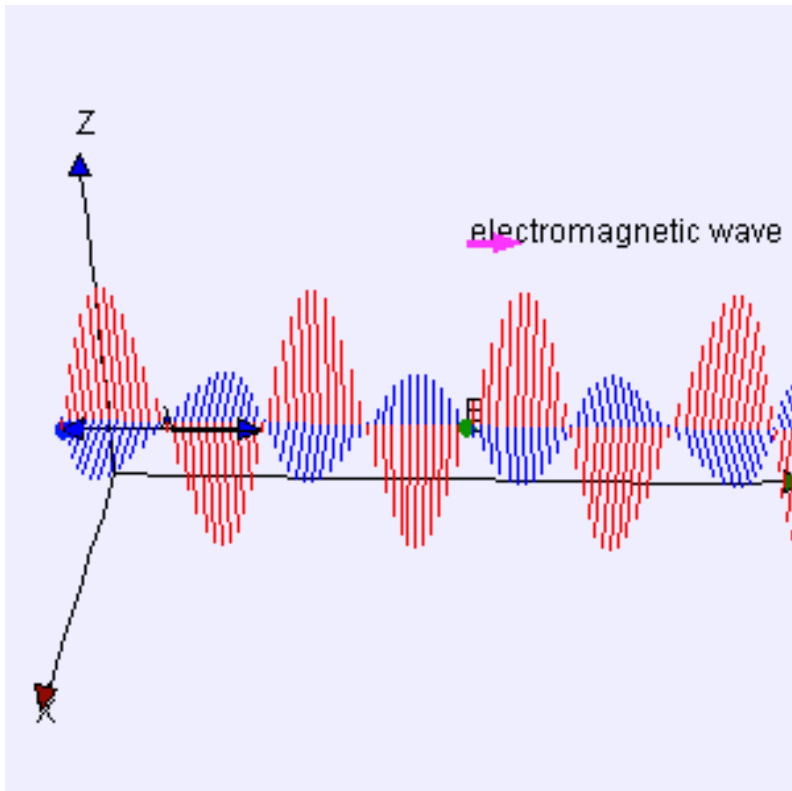

Polarisiertes Licht

Linearpolarisiert:

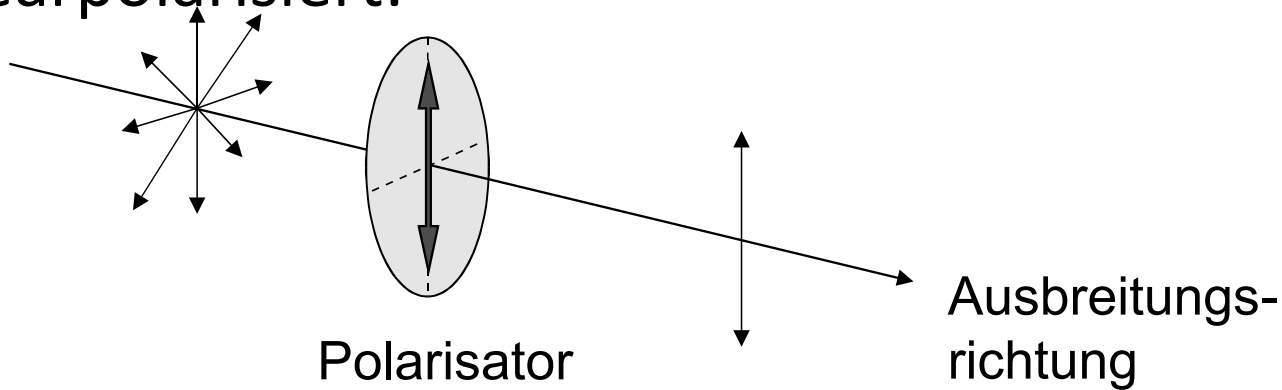

Cirkulär polarisiert

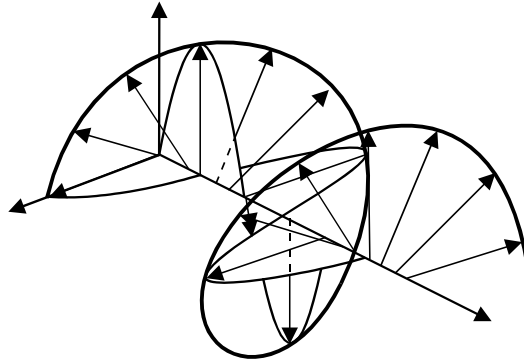

Cirkulärpolarisiertes
Licht

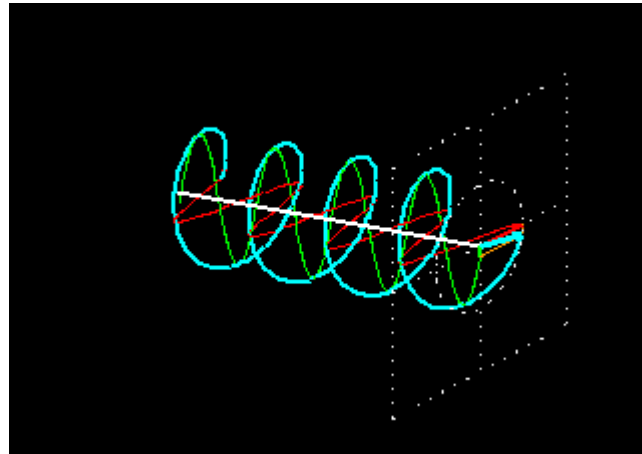

Linear = Links + Rechts

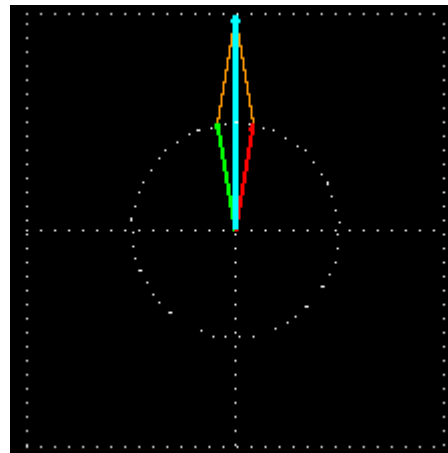

Viertel-Wellenlänge Platte -> macht Cirk.Pol.

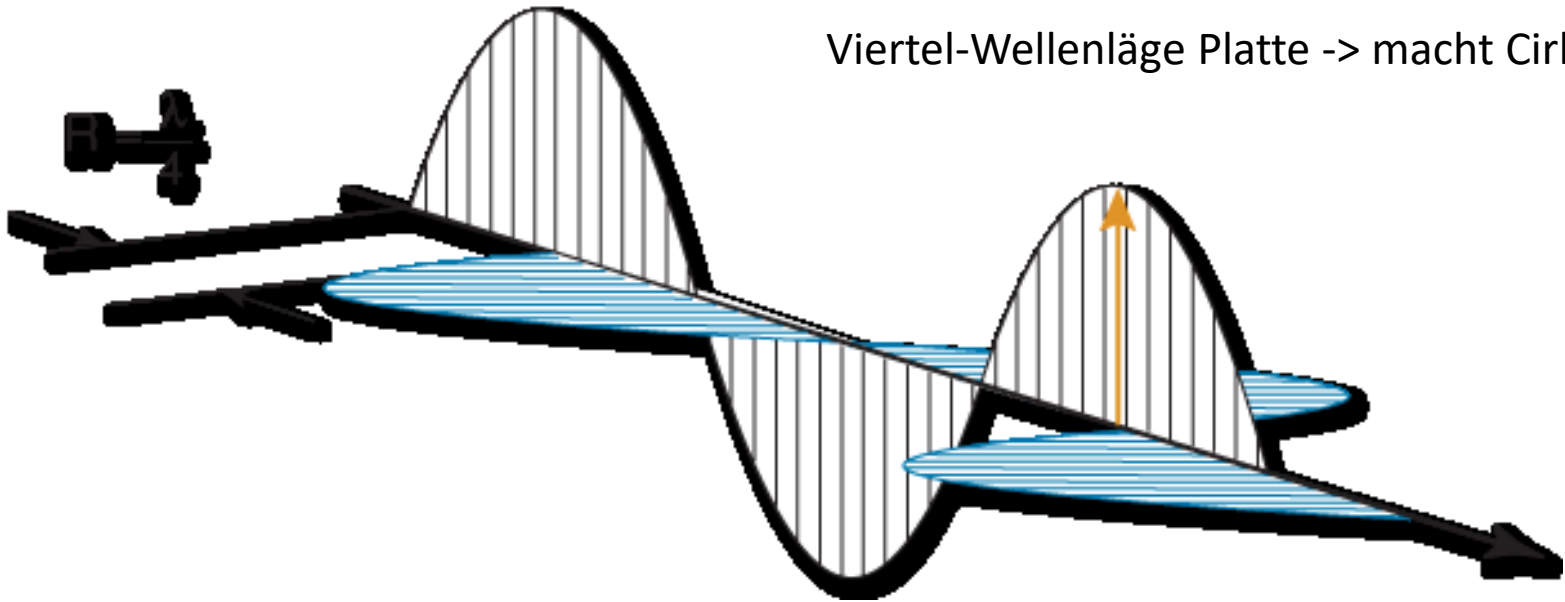

Halb-Wellenlänge Platte -> Dreht Pol.Richtung um 90 Grad.

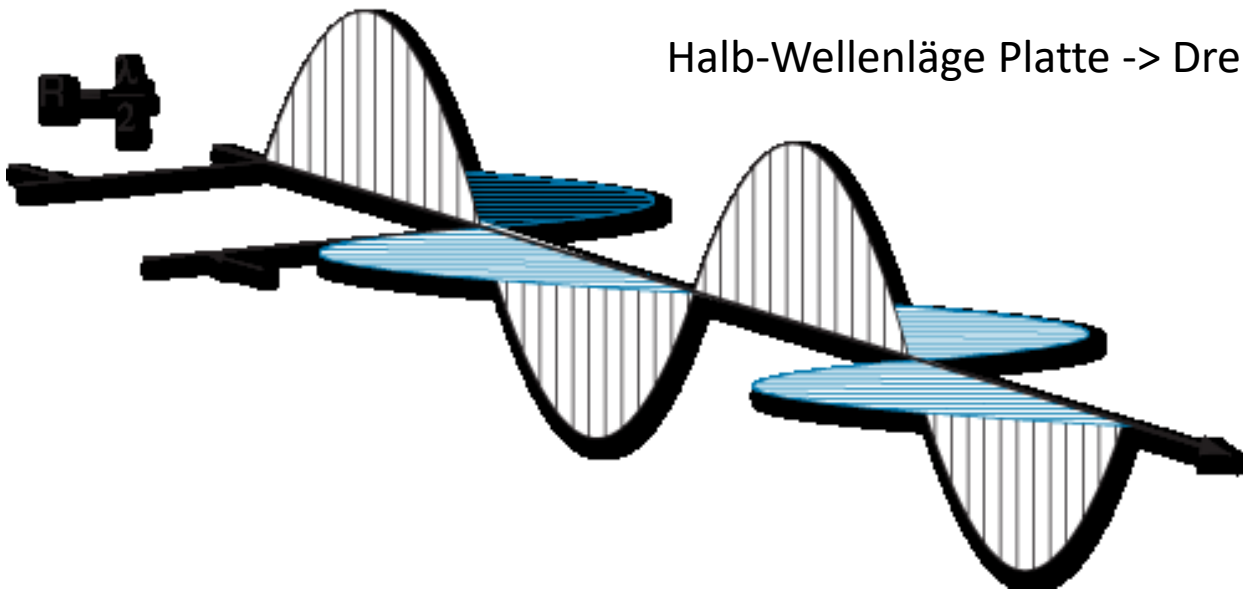

PEM: Photo Elastic Modulator

Dies ist ein Kristall, welche unter Stauchungsstress Doppelbrechend wird.

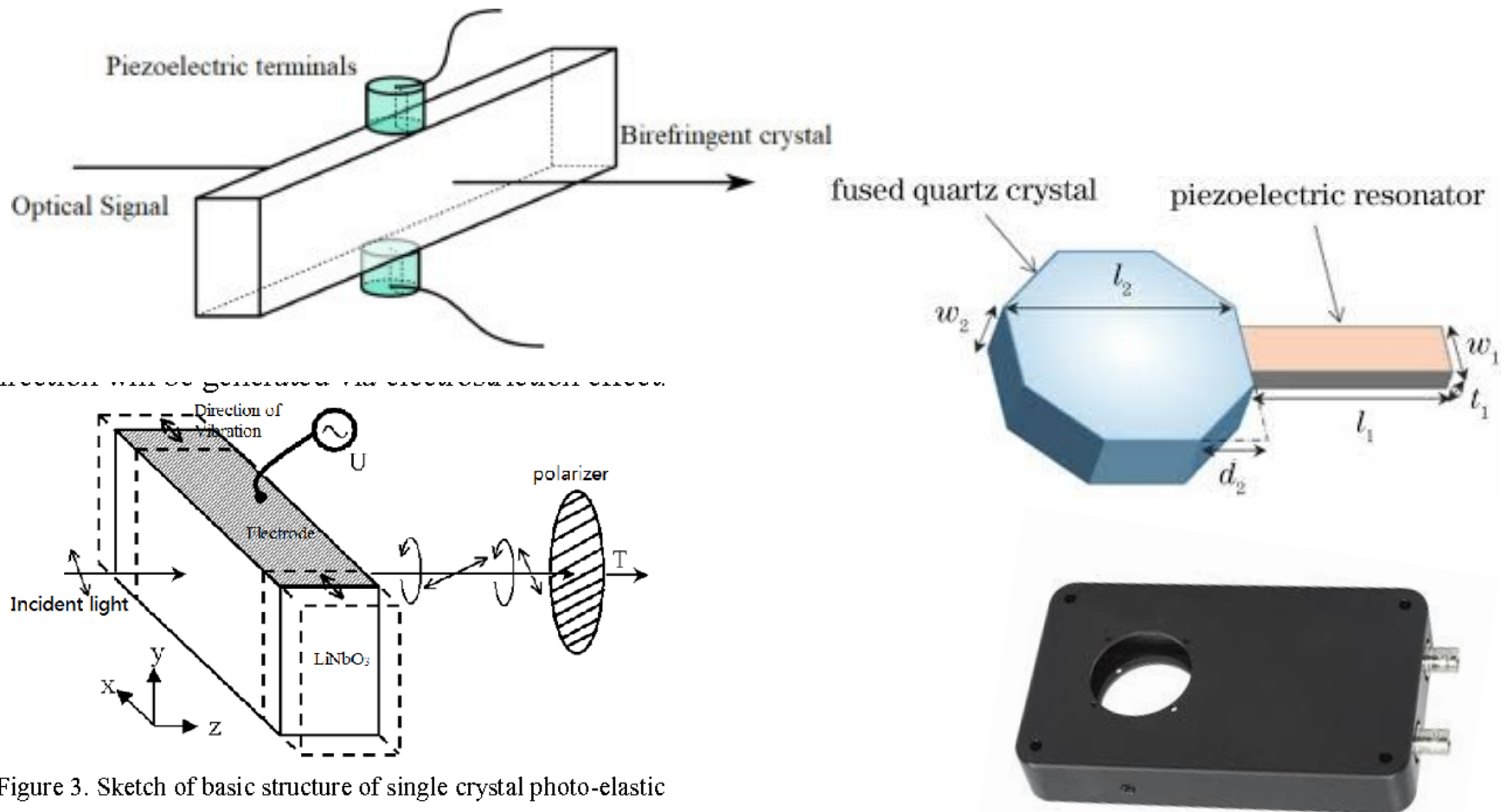
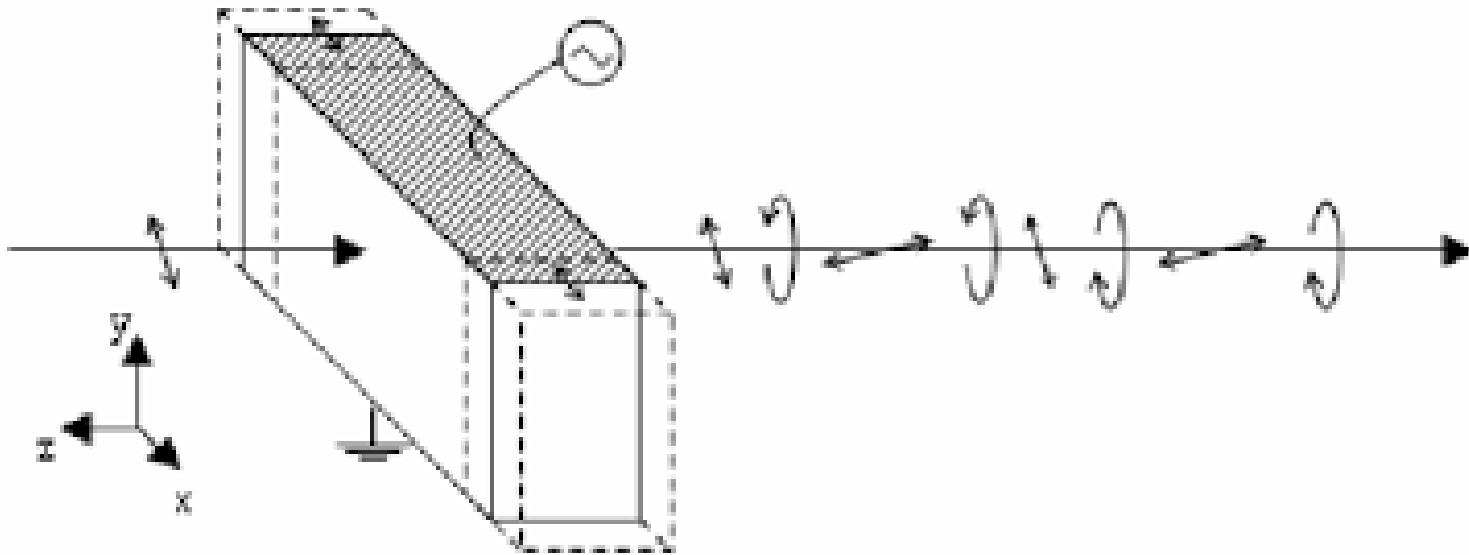

Figure 3. Sketch of basic structure of single crystal photo-elastic modulator (SCPEM)



Am einfachsten benutzt man Resonanz, also treibt den Kristall mit dem Eigenfrequenz.

Dann bekommen wir periodische Lichtdrehung: Manchmal Linear, dann Rechts, dann wieder linear, dann Links, etc..

Chirale Stoffe: **Absorbanz** und Brechzahl sind
Drehrichtungsabhängig:

$A_{\text{Links}} \neq A_{\text{Rechts}}$ und $n_{\text{Links}} \neq n_{\text{Rechts}}$

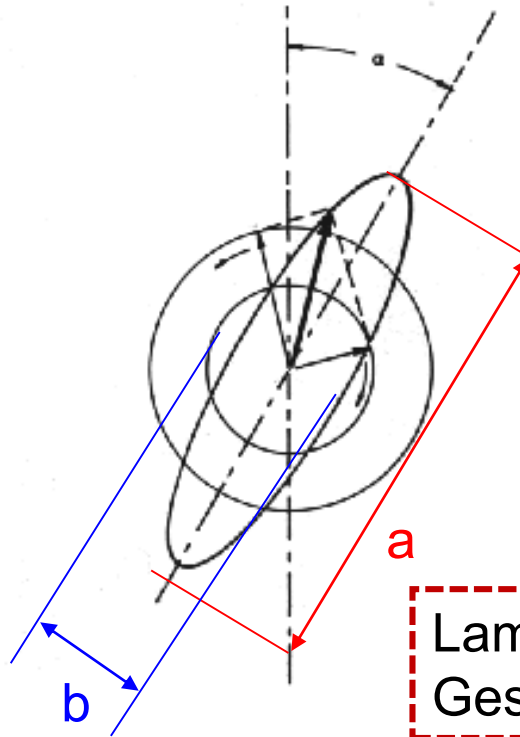
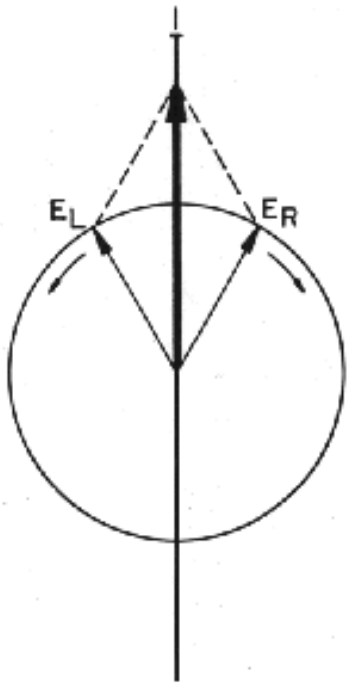

$$\Delta A = A_L - A_R = \Delta \varepsilon c x$$

$$\Delta \varepsilon = \varepsilon_L - \varepsilon_R$$

Elliptizität: θ $\text{tg } \theta = b/a$

$$\theta = \frac{\ln 10}{4} (A_L - A_R) \cdot \frac{180}{\pi} \quad [\text{Grad}]$$

Lambert-Beer ähnliches
Gesetz: $\theta = c \cdot l \cdot \theta_m$

(θ_m : molare Elliptizität)

CD-spektrometer

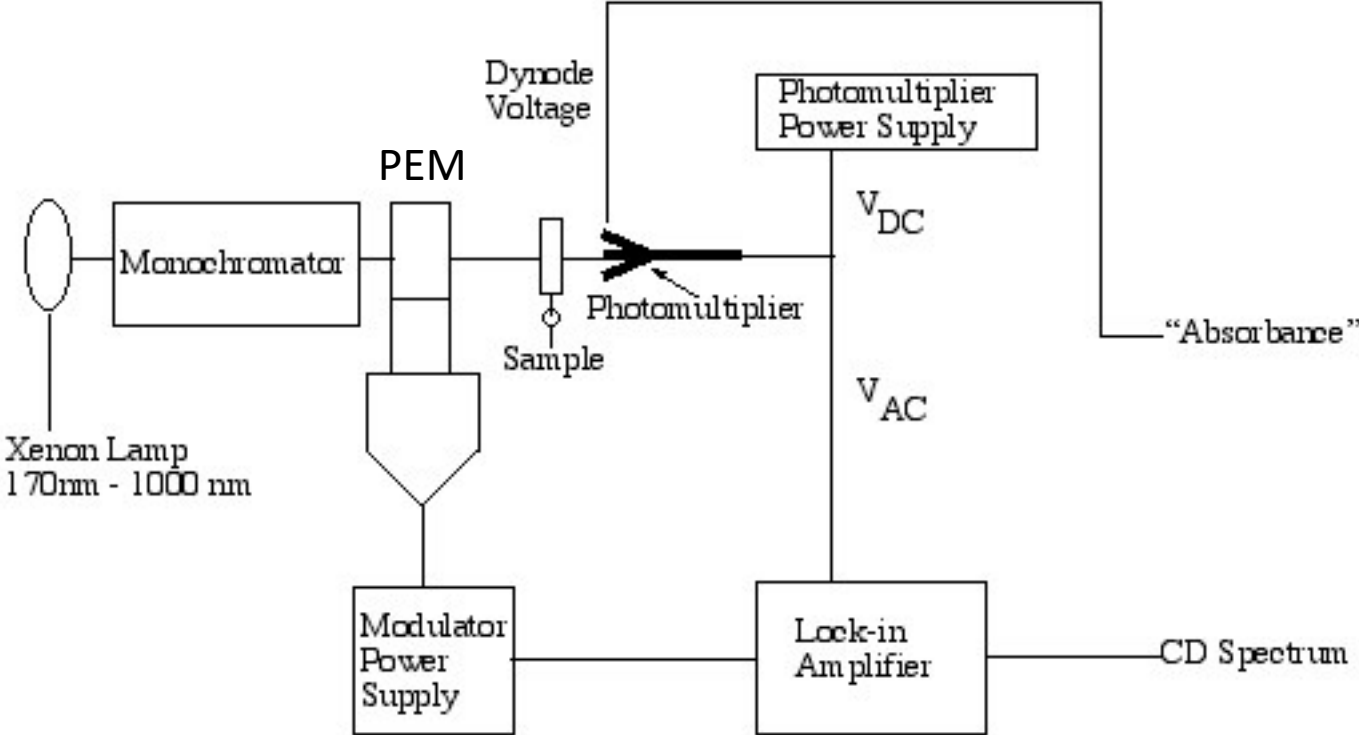

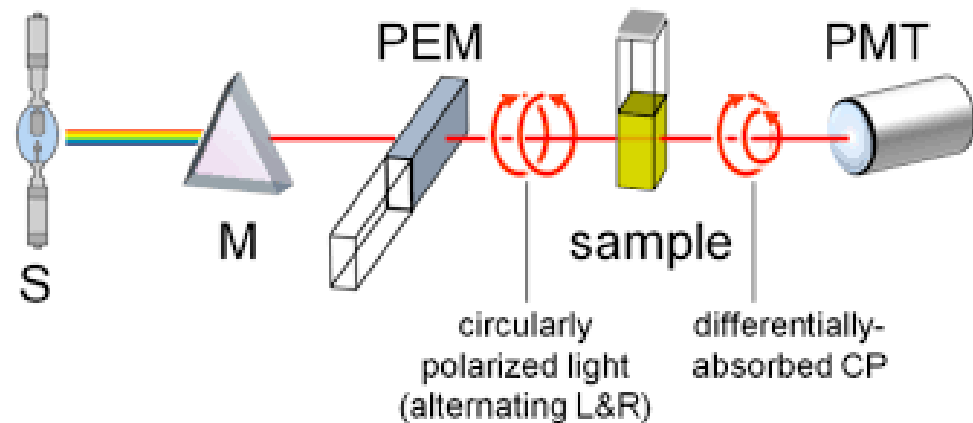
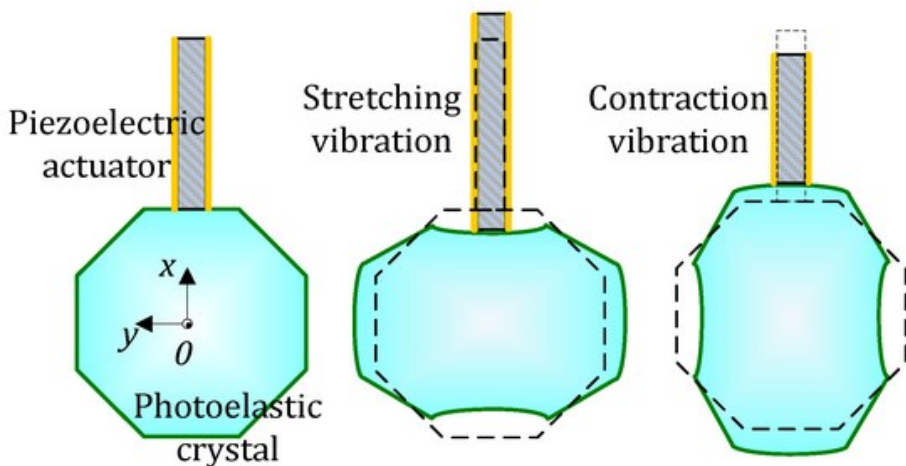
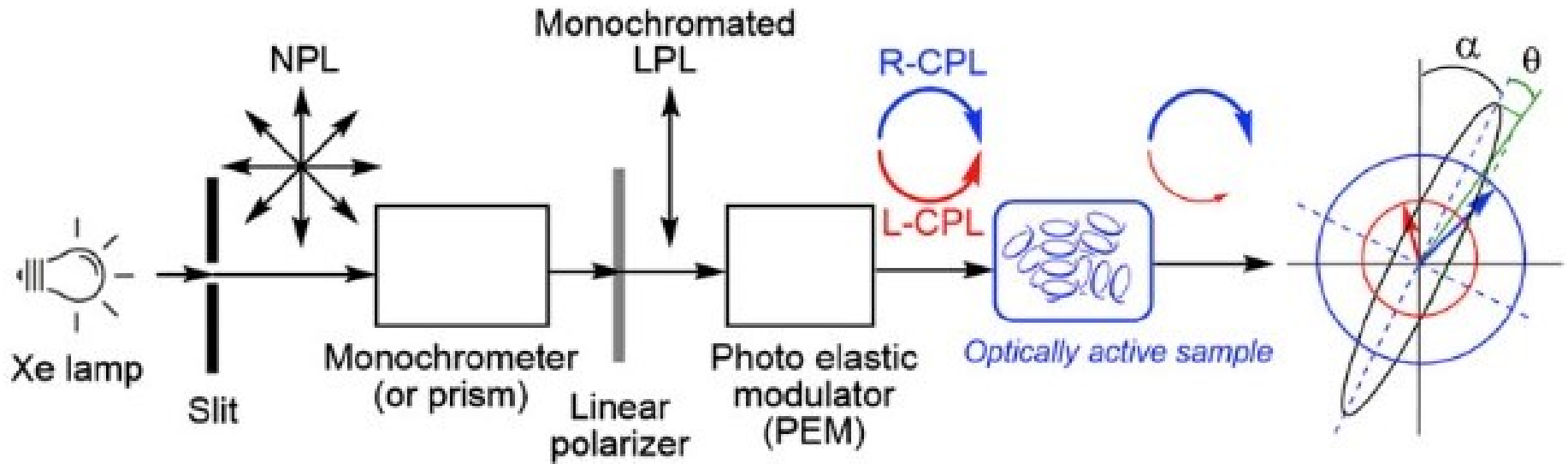
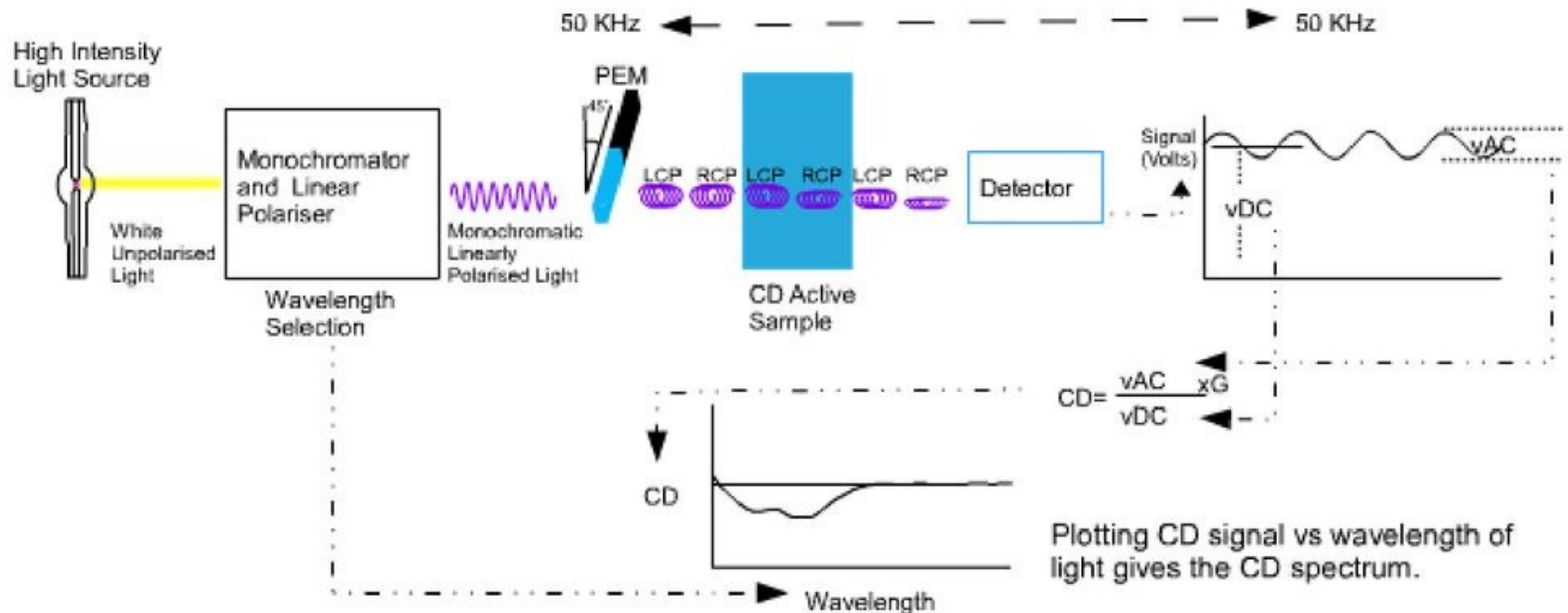

Photo Elastizitätseffekt = Piezo-optisches Effekt

Spannungsoptik

Materien unter mechanischem Stress werden Doppelbrechig.

CD spectrophotometer



im tief-UV ist θ empfindlich für die sekundäre Struktur der Eiweißstoffe.

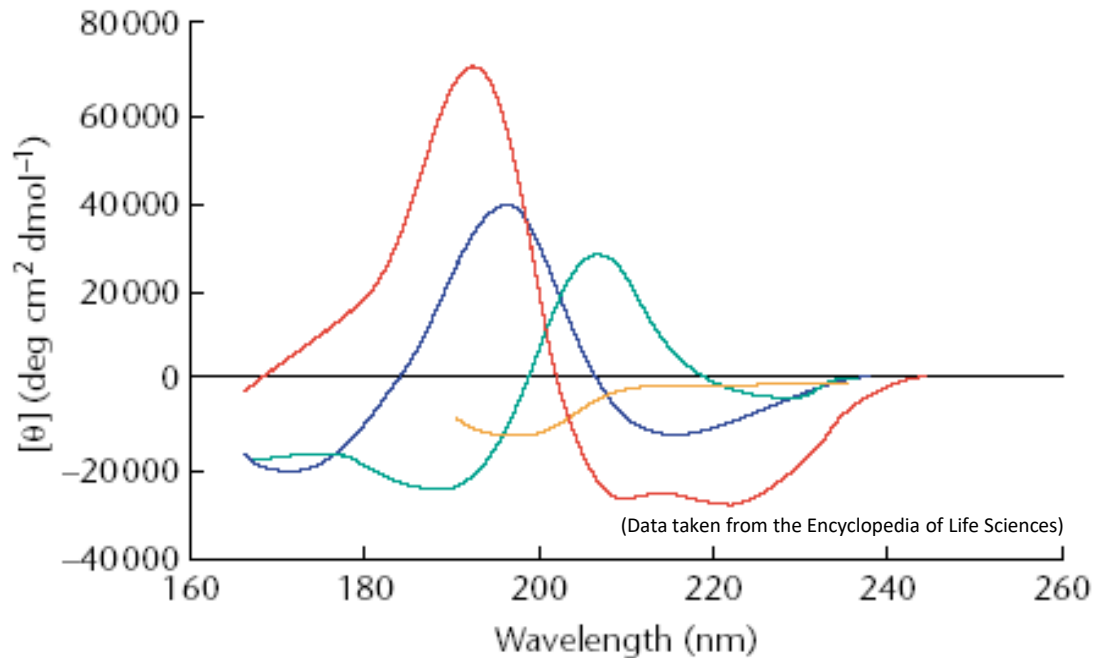

α -helix

Typ I. β -turn

antiparallel β

unstrukturiert

Choose wavelength range:

- 175-250 nm
- 180-250 nm
- 185-250 nm
- 190-250 nm
- 195-250 nm
- 200-250 nm

Scale factor

[Recalculate](#)

Recalculation for the spectrum multiplied by the scale factor in the chosen wavelength range.

[Best factor](#)

Dependence of the secondary structure estimation and NRMSD of fitting upon the spectral amplitude (use of NRMSD as hint for correction is advised only for the 175-250 and 180-250 nm ranges).

[Fold recognition](#)

Prediction of fold class, architecture and topology (CATH classification) based on the results of the secondary structure determination. This function is available when the secondary structure is estimated in the Single spectrum analysis.

[Back](#)

Back to the starting page. Data will be lost.

References: Micsonai et al. Nucleic Acids Res. 46:W315-22 (2018), Micsonai et al. PNAS 11:E3095-103 (2015)

[Header](#)

Title		Wavelength range	175-250 nm
Date/time	5-05-2023 19:16 (GMT+1:00)	Scale factor	1

[Secondary structure](#)

Estimated secondary structure content (%)

Helix	2.4	Helix1 (regular)	2.4
		Helix2 (distorted)	0.0
Antiparallel	64.0	Anti1 (left-twisted)	9.7
		Anti2 (relaxed)	23.5
		Anti3 (right-twisted)	30.8
Parallel	0.0		
Turn	8.3		
Others	25.3		

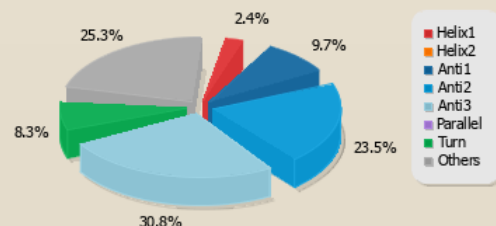

[Fitting results](#)

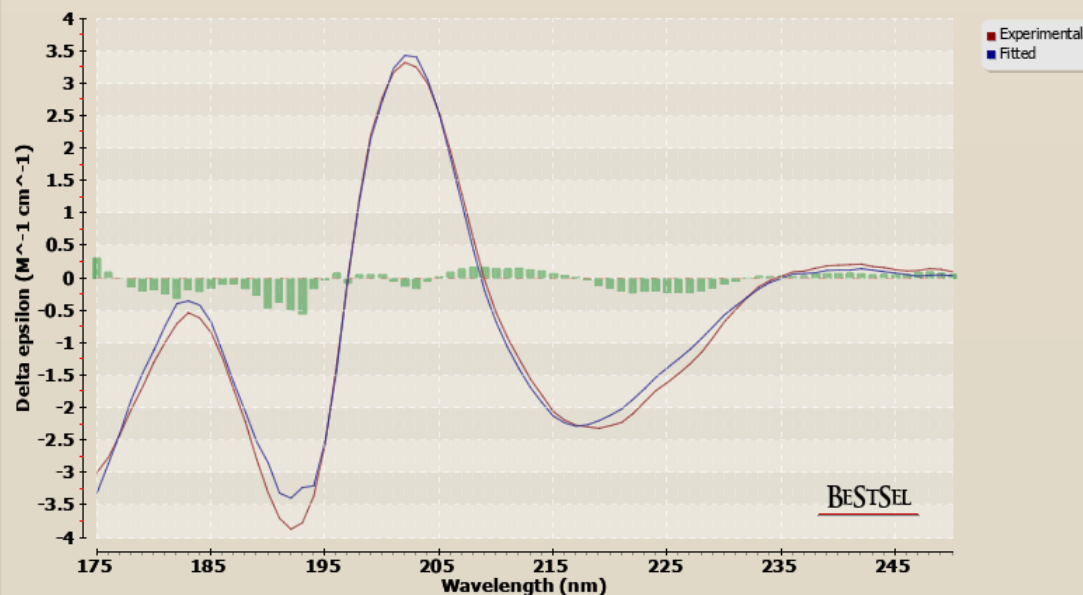

RMSD **0.1736** NRMSD **0.02414**

[Comments](#)

- Input in text window.
- No project title provided. Title will be generated automatically.
- Maximum usable wavelength range: 175-250 nm

Secondary structure

Estimated secondary structure content (%)

Helix	2.4	Helix1 (regular)	2.4
		Helix2 (distorted)	0.0
Antiparallel	64.0	Anti1 (left-twisted)	9.7
		Anti2 (relaxed)	23.5
		Anti3 (right-twisted)	30.8
Parallel	0.0		
Turn	8.3		
Others	25.3		

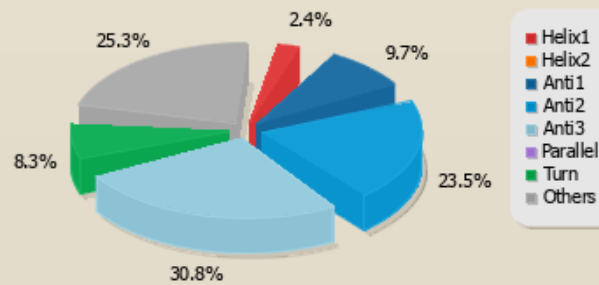

1KU8

jakalin

Zuckerbindendes
Eiweißstoff.

Fitting results

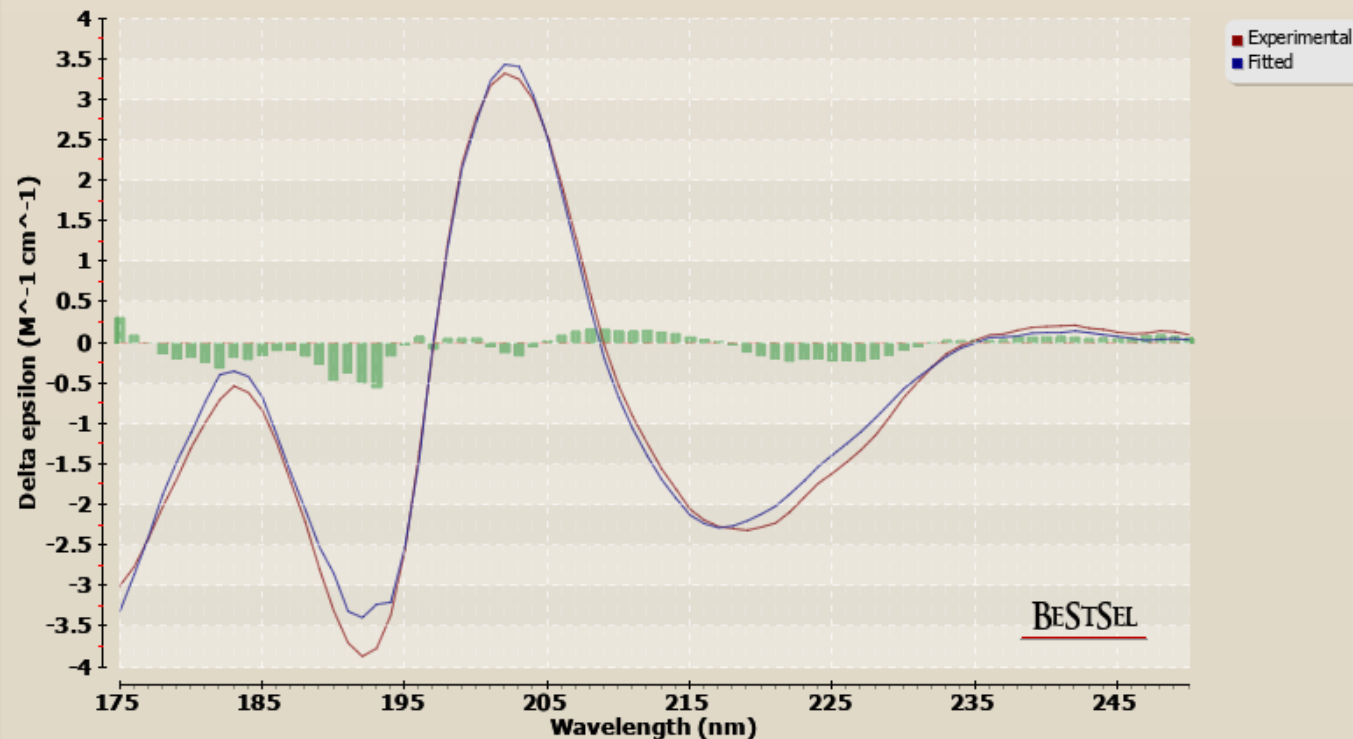

RMSD **0.1736** NRMSD **0.02414**

Comments

- Input in text window.
- No project title provided. Title will be generated automatically.
- Maximum usable wavelength range: 175-250 nm

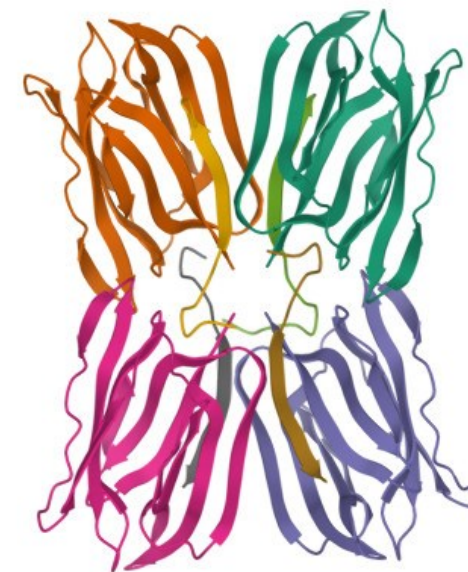

The Structure and CD spectrum of Subtilisin

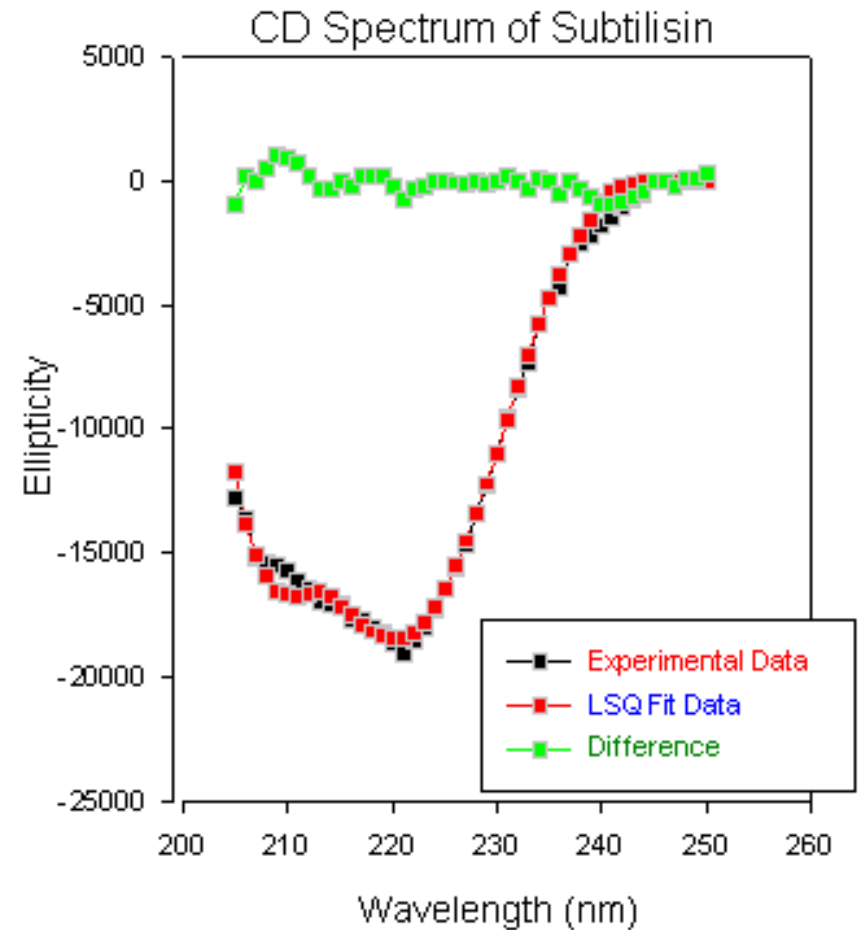

helix	sheet	coil
57.92	26.22	15.85

- A) triosephosphate isomerase
- B) hen egg lysozyme
- C) myoglobin
- D) chymotrypsin

